

# WhisperFloXF™

High Performance Pump

By Pentair Pool Products®



**Introducing** *The most energy-efficient pump in its class*



# All new, *from the inside out*

NEW upgraded dual-compartment motor allows simpler electrical installation

Diamond seals made of oxidation-resistant EPDM rubber for longer-lasting, leak-resistant performance

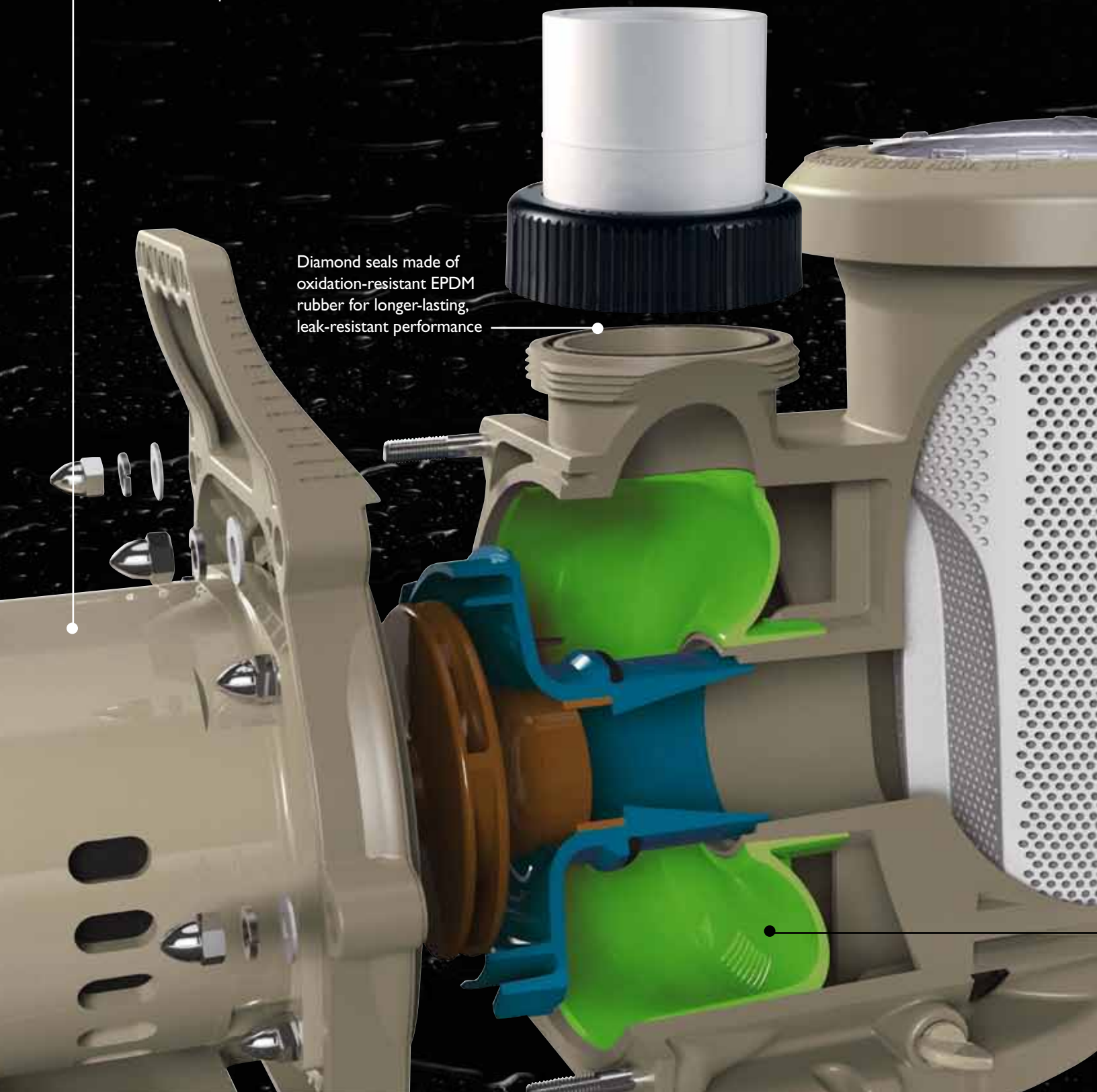

Now there's a pool pump for demanding high-capacity applications that's energy-efficient, whisper-quiet and dependable: the new WhisperFlo**XF**<sup>™</sup> high performance pump.

### Driven by new ideas.

Our engineers left the old assumptions behind. Calling on the latest computer-aided engineering tools, they developed a proprietary design that was completely rethought from the inside out. They achieved a level of streamlined fluid flow and precision manufacturing that simply wasn't possible in the past. And when their work was done, they had created the all-new WhisperFlo**XF** high performance pump—the most energy-efficient pump ever offered in its class.

### The power to do more.

The new WhisperFlo**XF** pump is the most efficient, technologically advanced WhisperFlo<sup>®</sup> pump we have ever manufactured. With outstanding performance from both a maximum-flow and mean-flow perspective, it's an ideal choice for commercial pools, as well as residential pools with waterfalls, slides and other water features.

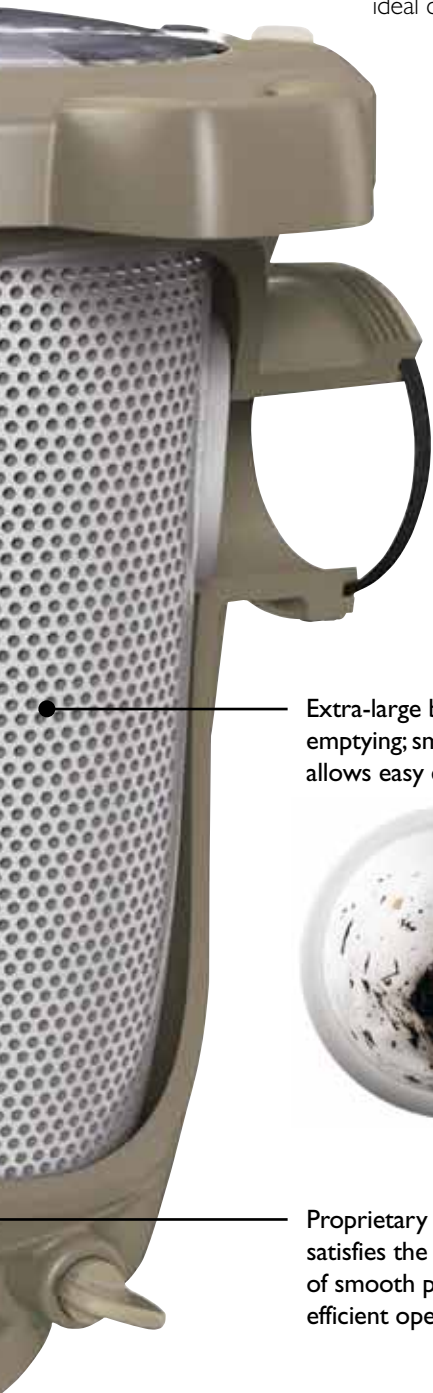

Extra-large basket needs less emptying; smooth surface allows easy debris removal



Proprietary hydraulic isolator satisfies the competing priorities of smooth priming and optimally efficient operation



NEW union connectors included—connects directly to 2.5" or 3" plumbing

### Performance Curves

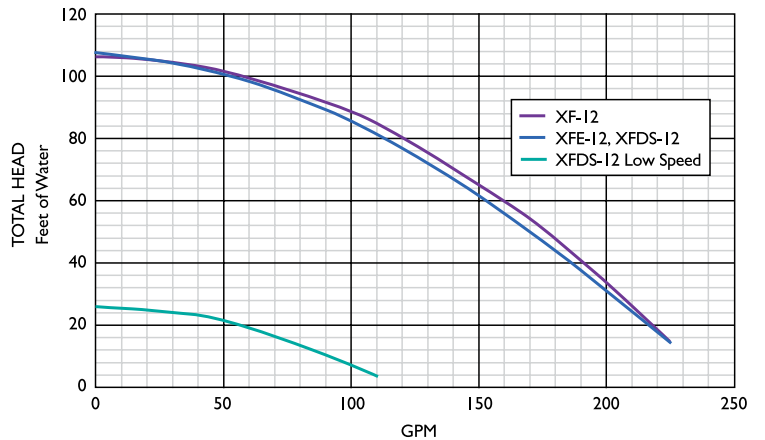

# WhisperFloXF™ High Performance Pump

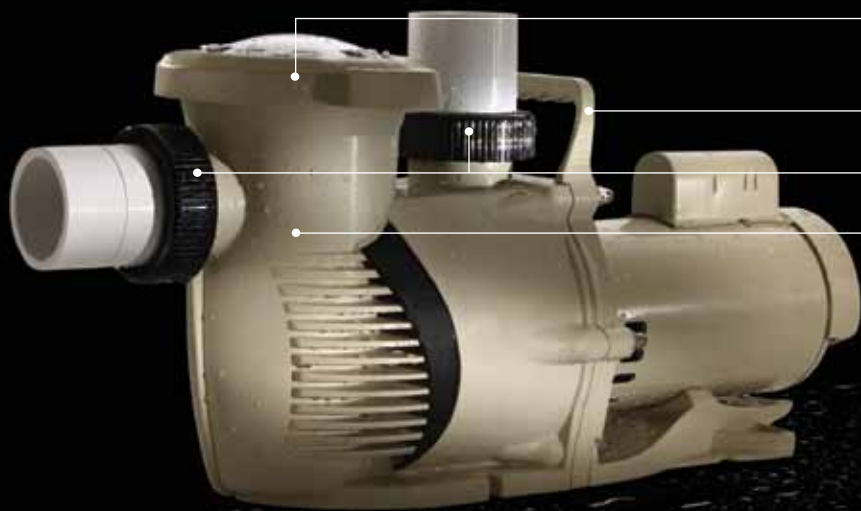

Cam and Ramp™ lid makes inspection and cleaning simple and quick

Built-in handle for easy installation

New 2.5" or 3" union connectors included

Oversized strainer basket extends time between cleanings

## High capacity meets high efficiency

With half a century's worth of dependable service to their credit, Pentair Water Pool and Spa® ("Pentair") pumps have been the first choice for over two million pool owners. Now the new WhisperFloXF™ high performance pump—the most powerful and energy-efficient WhisperFlo® pump in Pentair history—continues the tradition of installer-friendly design and hassle-free service life.

- New union connectors included—connects directly to 2.5" or 3" plumbing.
- Drop-in replacement for all WhisperFlo models. Simple replacement for Challenger® pumps.\*

- See-through lid makes basket inspection fast and easy.
- User-friendly Cam and Ramp™ lid removes easily and locks in place quickly with a quarter-turn.
- External port threads and included tool-free unions require only hand tightening for a perfect fit.
- Easy-carry handle is a back-saver at the equipment pad.

\*Riser base required for Challenger replacements—  
Part # 400012 available separately.

### Available from:



Because *reliability* matters most®

[www.pentairpool.com](http://www.pentairpool.com)

Phone: 800-831-7133

[pumps](#) / [filters](#) / [heaters](#) / [heat pumps](#) / [automation](#) / [lighting](#) / [cleaners](#) / [sanitizers](#) / [water features](#) / [maintenance products](#)