



* CV Standard Kit shown
(Part #VPK-CVSTD)

THE VERSA PLUMB SYSTEM

SAVE TIME, SAVE MONEY, SAVE ENERGY

Jandy has revolutionized plumbing pool equipment with the Versa Plumb System. The positioning of the inlet and outlet ports on Jandy's Versa Plumb Ready equipment maximizes hydraulic efficiency while minimizing equipment space and plumbing requirements.

These three preassembled plumbing kits make connecting your equipment simple.

THREE PREASSEMBLED KITS AVAILABLE

- **CV Standard Kit (Part #VPK-CVSTD)** Kit for Jandy Pump, CV Filter and LXi Heater
- **CV Solar Kit (Part #VPK-CVSLR)** Kit for Jandy Pump, CV Filter and LXi Heater - with solar ready plumbing. **This solar kit ensures compliance with California Energy Commission's 2008 Building Energy Efficiency Standards (Title 24)**
- **CS Standard Kit (Part #VPK-CSSTD)** Kit for Jandy Pump, CS Filter and Heat Pump

FEATURES & BENEFITS





- **Convenience** Easy to install kits ensure hydraulic efficiency and compact, consistent equipment set layout
- **Efficiency** Saves time and labor costs. Ensures hydraulic efficiency by lowering TDH
- **Options** Each kit contains 3-port Jandy NeverLube® valves

VERSA PLUMB® PREASSEMBLED PLUMBING KITS

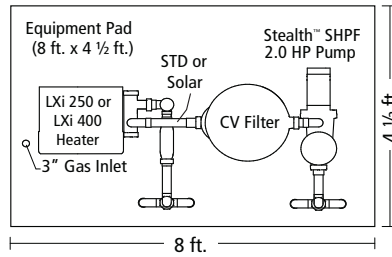
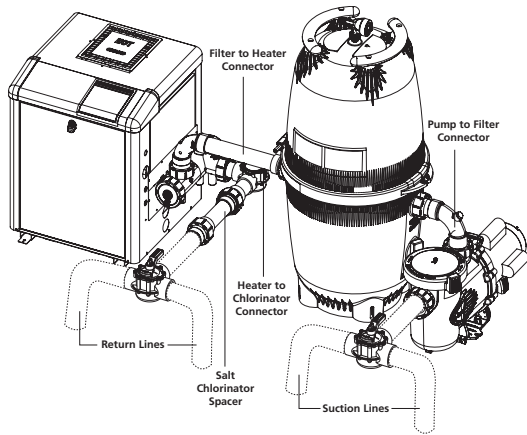
CV Standard Kit (Part #VPK-CVSTD)

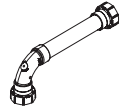
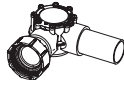
Kit for Jandy® Pump, CV Filter and LXi Heater

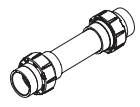







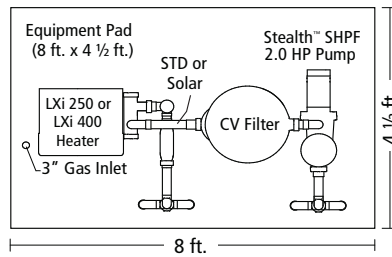
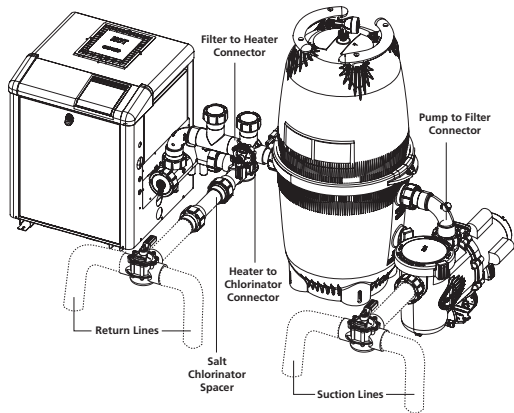

CV Solar Kit (Part #VPK-CVSLR)

Kit for Jandy Pump, CV Filter and LXi Heater - with solar ready plumbing.

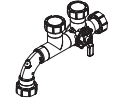
This solar kit ensures compliance with California Energy Commission's 2008 Building Energy Efficiency Standards (Title 24)

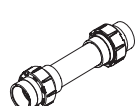





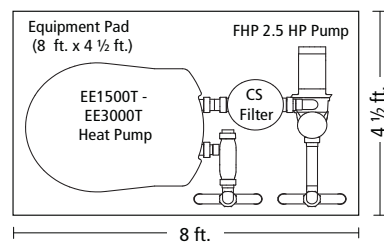
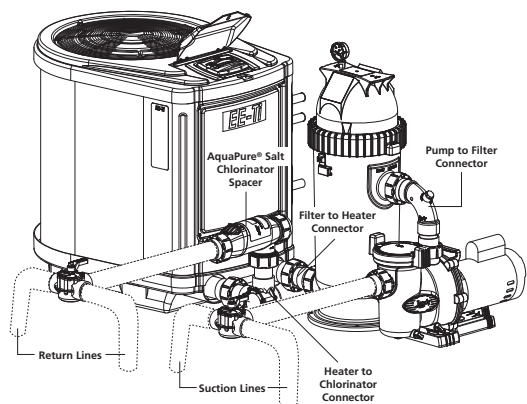

CS Standard Kit (Part #VPK-CSSTD)

Kit for Jandy Pump, CS Filter and Heat Pump



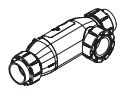

Pumps • Filters • Heaters • Heat Pumps • Controls • Lights • Water Purification • Valves
Water Features • Water Leveling • Cleaners • In-Floor • Pool Covers • Accessories