

# 2.70 THP VS Pump Family

## Owner's Manual

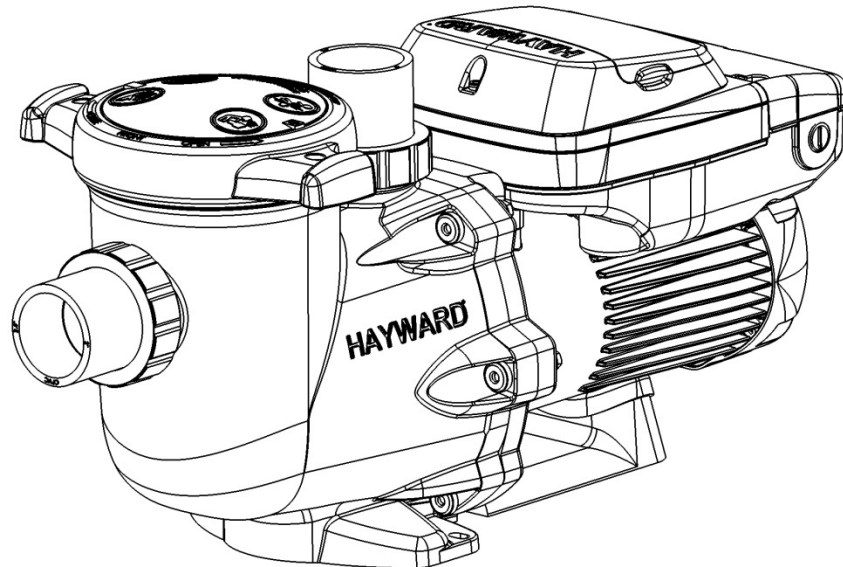

### 2.70 THP Variable Speed Pump Family

Hayward's 2.70 THP variable speed pump family is the industry's most energy efficient variable speed pump. The totally enclosed, permanent magnet motor combined with its advanced hydraulic design provides unparalleled energy savings. This pump is easily installed either as a programmable stand-alone pump or with a Hayward or third party controller and features an easy-to-use digital control interface that can be mounted in four different positions on the pump or removed and mounted on the wall for total user convenience.

SVRS models provide an added layer of protection from suction entrapment without additional devices, plumbing or wiring.

**Note:** To prevent potential injury and to avoid unnecessary service calls, read this manual carefully and completely.

## **SAVE THIS INSTRUCTION MANUAL**

Hayward Pool Products  
620 Division St, Elizabeth, NJ 07207  
Phone: (908) 355-7995  
[www.hayward.com](http://www.hayward.com)

## Table of Contents

1.	IMPORTANT SAFETY INSTRUCTIONS .....	4
2.	General Information .....	7
2.1.	Introduction	7
2.2.	Primary Features	7
2.3.	Product Dimensions	7
3.	Energy Efficiency Overview .....	8
4.	Installation and Wiring .....	8
4.1.	Pump Location	8
4.2.	Pump Mounting	9
4.3.	Pipe Sizing Chart	9
4.4.	Plumbing	9
4.5.	Electrical	10
4.6.	Electrical Specs	10
4.7.	Voltage	10
4.8.	Grounding and Bonding	10
4.9.	Wiring	10
4.10.	Remote Control Wiring/Operation	11
4.11.	SVRS Notes (Only applicable to SVRS pump models)	11
4.12.	Digital Control Interface Orientation	11
4.13.	Interface Wall Mounting	12
4.14.	Installation Procedure	14
5.	Wiring Diagrams .....	14
5.1.	Input Power Wiring (Required)	14
5.2.	Hayward Automation Control Wiring (Optional, for remote control of pump speed)	15
5.3.	External Relay Speed Control Wiring (Optional, for remote selection of pump speed)	16
5.4.	Wall Mounted Digital Control Interface Wiring (Optional)	17
5.5.	Remote Stop Switch Wiring (Optional)	18
6.	Startup & Operation .....	18
6.1.	Prior to Start-Up	18
6.2.	Starting/Priming the Pump	19
6.3.	User Interface Summary	20
6.4.	Menu Outline	21
6.5.	Initial startup	21
6.6.	Configuration Menu	22
6.7.	Timer Menu	24
6.8.	Preset Speed Setup Menu	25
6.9.	Diagnostic Menu	26
6.10.	Stop/Resume	26
6.11.	Quick Clean	27
6.12.	Remote Stop	27
7.	Maintenance .....	27
8.	Storage / Winterization .....	28
8.1.	Storing Pump For Winterization	28
9.	Shaft Seal Change Instructions .....	28

USE ONLY HAYWARD GENUINE REPLACEMENT PARTS



9.1. Removing the Motor Assembly	28
9.2. Removing the Impeller	29
9.3. Removing the Ceramic Seat	29
9.4. Seal Installation	29
9.5. Replacing the Impeller and Diffuser	29
9.6. Replacing the Motor Assembly	29
10. Replacement Parts.....	30
10.1. Parts Diagram	30
10.2. Parts Listing	30
11. Troubleshooting .....	32
11.1. General Problems	32
11.2. Check System Messages	33
12. Warranty.....	34
13. Product Registration .....	35

USE ONLY HAYWARD GENUINE REPLACEMENT PARTS

# 1. IMPORTANT SAFETY INSTRUCTIONS

Before installing or servicing this electrical equipment, turn power supply OFF.

Basic safety precautions should always be followed, including the following: Failure to follow instructions may result in injury.

 This is the safety-alert symbol. When you see this symbol on your pump or in this manual, look for one of the following signal words, and be alert to the potential for personal injury.

 **WARNING** warns about hazards that **could** cause serious personal injury, death or major property damage and if ignored presents a potential hazard.

 **CAUTION** warns about hazards that **will** or **can** cause minor or moderate personal injury and/or property damage and if ignored presents a potential hazard. It can also make consumers aware of actions that are unpredictable and unsafe.

The **NOTICE** label indicates special instructions that are important but not related to hazards.



 **WARNING – READ AND FOLLOW ALL INSTRUCTIONS** in this owner's manual and on the equipment. Failure to follow instructions can cause severe injury and/or death.

 **WARNING** – This product should be installed and serviced only by a qualified professional.

 **CAUTION** – All electrical wiring **MUST** be in conformance with all applicable local codes, regulations, and the National Electric Code (NEC).

**USE OF NON-HAYWARD REPLACEMENT PARTS VOIDS WARRANTY.**

**ATTENTION INSTALLER - THIS MANUAL CONTAINS IMPORTANT INFORMATION ABOUT THE INSTALLATION, OPERATION, AND SAFE USE OF THIS VARIABLE SPEED PUMP THAT MUST BE FURNISHED TO THE END USER OF THIS PRODUCT. FAILURE TO READ AND FOLLOW ALL INSTRUCTIONS COULD RESULT IN SERIOUS INJURY.**

 **WARNING** – To reduce risk of injury, do not permit children to use or climb on this product. Closely supervise children at all times. Components such as the filtration system, pumps, and heaters must be positioned to prevent children from using them as a means of access to the pool.

 **CAUTION** – This pump is intended for use on permanently installed swimming pools and may also be used with hot tubs and spas if so marked. Do NOT use with storable pools. A permanently installed pool is constructed in or on the ground or in a building such that it cannot be readily disassembled for storage. A storable pool is constructed so that it is capable of being readily disassembled for storage and reassembled to its original integrity. Though this product is designed for outdoor use, it is strongly advised to protect the electrical components from the weather. Select a well-drained area, one that will not flood when it rains. It requires free circulation of air for cooling. Do not install in a damp or non-ventilated location. If installed within an outer enclosure or beneath the skirt of a hot tub or spa, adequate ventilation and free circulation of air must be provided to prevent overheating of the motor.

USE ONLY HAYWARD GENUINE REPLACEMENT PARTS

 **WARNING** – Pool and spa components (seals, gaskets, etc.) have a finite life. All components should be inspected frequently and replaced at least every ten years, or if found to be damaged, broken, cracked, missing, or not securely attached.



 **WARNING** – **Risk of Electric Shock.** All electrical wiring **MUST** be in conformance with applicable local codes, regulations, and the National Electric Code (NEC). Hazardous voltage can shock, burn, and cause death or serious property damage. To reduce the risk of electric shock, do **NOT** use an extension cord to connect unit to electric supply. Provide a properly located electrical receptacle. Before working on pump or motor, turn off power supply to the pump.

 **WARNING** – To reduce the risk of electric shock replace damaged wiring immediately. Locate conduit to prevent abuse from lawn mowers, hedge trimmers and other equipment.

 **WARNING** – **Risk of Electric Shock.** In accordance with the National Electric Code (NEC), connect only to a branch circuit protected by a ground-fault circuit-interrupter (GFCI). Contact a qualified electrician if you cannot verify that the circuit is protected by a GFCI. The unit must be connected only to a supply circuit that is protected by a ground-fault circuit-interrupter (GFCI). Such a GFCI should be provided by the installer and should be tested on a routine basis. To test the GFCI, push the test circuit button. The GFCI should interrupt power. Push the reset button. Power should be restored. If the GFCI fails to operate in this manner, the GFCI is defective. If the GFCI interrupts power to the pump without the test button being pushed, a ground current is flowing, indicating the possibility of an electric shock. Do not use this pump. Disconnect the pump and have the problem corrected by a qualified service representative before using.

 **WARNING** – Failure to bond pump to pool structure will increase risk for electrocution and could result in injury or death. To reduce the risk of electric shock, see installation instructions and consult a professional electrician on how to bond pump. Also, contact a licensed electrician for information on local electrical codes for bonding requirements.

**Notes to electrician:** Use a solid copper conductor, size 8 or larger. Run a continuous wire from external bonding lug to reinforcing rod or mesh. Connect a No. 8 AWG (8.4 mm<sup>2</sup>) [No. 6 AWG (13.3 mm<sup>2</sup>) for Canada] solid copper bonding wire to the pressure wire connector provided on the pump housing and to all metal parts of swimming pool, spa, or hot tub, and to all electrical equipment, metal piping (except gas piping), and conduit within 5 ft. (1.5 m) of inside walls of swimming pool, spa, or hot tub. **IMPORTANT** - Reference NEC codes for all wiring standards including, but not limited to, grounding, bonding and other general wiring procedures.

 **WARNING** – **Suction Entrapment Hazard.** Suction in suction outlets and/or suction outlet covers, which are damaged, broken, cracked, missing, or unsecured cause severe injury and/or death due to the following entrapment hazards (symbols complements of APSP):



**Hair Entrapment** - Hair can become entangled in suction outlet cover.



**Limb Entrapment** - A limb inserted into an opening of a suction outlet sump or suction outlet cover that is damaged, broken, cracked, missing, or not securely attached can result in a mechanical bind or swelling of the limb.



**Body Suction Entrapment** - A differential pressure applied to a large portion of the body or limbs can result in an entrapment.



**Evisceration/ Disembowelment** - A negative pressure applied directly to the intestines through an unprotected suction outlet sump or suction outlet cover which is damaged, broken, cracked, missing, or unsecured can result in evisceration/disembowelment.

**Mechanical Entrapment** - There is potential for jewelry, swimsuits, hair decorations, fingers, toes, or knuckles to be caught in an opening of a suction outlet cover resulting in mechanical entrapment.

**Note:** See section 4.11 for SVRS-related notes

USE ONLY HAYWARD GENUINE REPLACEMENT PARTS

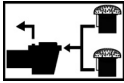
 **WARNING** – To Reduce the risk of Entrapment Hazards:

- When outlets are small enough to be blocked by a person, a minimum of two functioning suction outlets per pump must be installed. Suction outlets in the same plane (i.e. floor or wall), must be installed a minimum of three feet (3') [0.91 meter] apart, as measured from near point to near point.
- Dual suction fittings shall be placed in such locations and distances to avoid “dual blockage” by a user.
- Dual suction fittings shall not be located on seating areas or on the backrest for such seating areas.
- The maximum system flow rate shall not exceed the values shown in the “Pipe Sizing Chart” found in section 4.3 below.
- Never use pool or spa if any suction outlet component is damaged, broken, cracked, missing, or not securely attached.
- Replace damaged, broken, cracked, missing, or not securely attached suction outlet components immediately.
- In addition to two or more suction outlets per pump installed in accordance with latest APSP standards and CPSC guidelines, follow all national, state, and local codes applicable.
- Installation of a vacuum release or vent system, which relieves entrapping suction, is recommended.





 **WARNING – Hazardous Pressure.** Pool and spa water circulation systems operate under hazardous pressure during start-up, normal operation, and after pump shut-off. Stand clear of circulation system equipment during pump start-up. Failure to follow safety and operation instructions could result in violent separation of the pump housing and cover due to pressure in the system, which could cause property damage, severe personal injury, or death. Before servicing pool and spa water circulation system, all system and pump controls must be in off position and filter manual air relief valve must be in open position. Before starting pump, all system valves must be set in a position to allow system water to return back to the pool. Do not change filter control valve position while pump is running. Before starting pump, fully open filter manual air relief valve. Do not close filter manual air relief valve until a steady stream of water (not air or air and water mix) is discharged from the valve. All suction and discharge valves **MUST** be OPEN when starting the circulation system. Failure to do so could result in severe personal injury and/or property damage.



 **WARNING – Separation Hazard.** Failure to follow safety and operation instructions could result in violent separation of pump components. Strainer cover must be properly secured to pump housing with strainer cover lock ring. Before servicing pool and spa circulation system, all system and pump controls must be in off position and filter manual air relief valve must be in open position. Do not operate pool and spa circulation system if a system component is not assembled properly, damaged, or missing. Do not operate pool and spa circulation system unless filter manual air relief valve body is in locked position in filter upper body. All suction and discharge valves **MUST** be OPEN when starting the circulation system. Failure to do so could result in severe personal injury and/or property damage.

 **WARNING** – Never operate the circulation system at more than 50 PSI maximum.

 **WARNING – Fire and burn hazard.** Motors operate at high temperatures and if they are not properly isolated from any flammable structures or foreign debris they can cause fires, which may cause severe personal injury or death. It is also necessary to allow the motor to cool for at least 20 minutes prior to maintenance to minimize the risk for burns.

 **WARNING** – Failure to install according to defined instructions may result in severe personal injury or death.

## **SAVE THESE INSTRUCTIONS**

USE ONLY HAYWARD GENUINE REPLACEMENT PARTS

## 2. General Information

### 2.1. Introduction

This manual contains information for the proper installation and operation of the Hayward 2.70 THP variable speed pump family. The instructions in this manual **MUST** be followed precisely.

### 2.2. Primary Features

- Totally enclosed, permanent magnet motor
- Advanced hydraulic design
- SVRS model available compliant to ASME 112.19.17 Safety Vacuum Release System (SVRS) standard
- Fully programmable with a self-contained 24-hour clock and up to 8 custom speed and timer functions
- For enhanced pool management, can be controlled by Hayward or third party pool and spa control platforms, without the need for additional accessories
- Digital control interface that can be mounted in four different positions on the pump or removed and mounted on the wall
- No-rib, extra large basket design ensures easy debris removal and extends time between cleanings
- Motor drive includes built-in protection for high temperatures and voltage fluctuations. Drive is also designed to withstand temperatures below freezing without issue

### 2.3. Product Dimensions

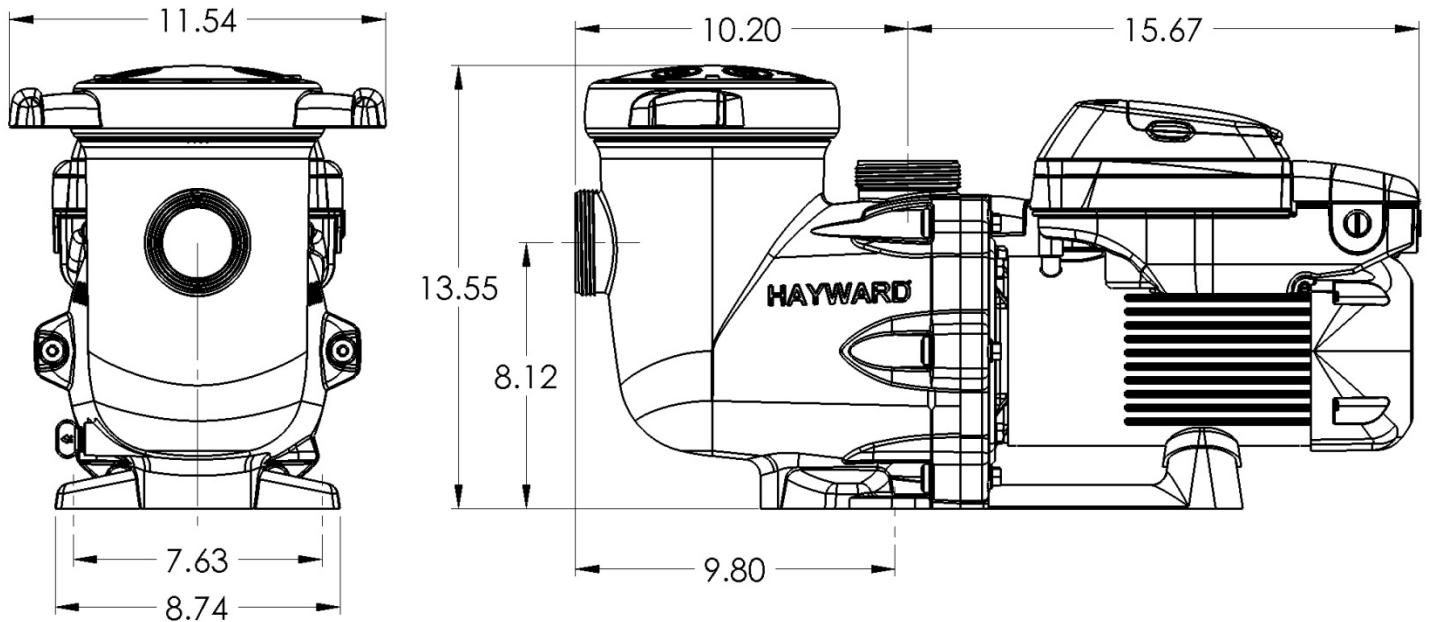

USE ONLY HAYWARD GENUINE REPLACEMENT PARTS

### 3. Energy Efficiency Overview

The energy consumed by a pool pump is measured in terms of Watts (W) or Kilowatts (kW). The 2.70 THP variable speed pump family displays power consumption in Watts. Given this information, you can determine the cost of operating the pump:

Power consumption of pump X Cost of electricity = Cost of Pump Operation per Hour

Example: Hayward variable speed pump operating at 300 W. Cost of electricity = \$0.10 per kWh

Convert Watts to Kilowatts: 300 W = 0.3 kW

0.3 kW X \$0.10/kWh = \$0.03 per hour

Note the power consumption is greatly affected by the speed of the pump. Lowering the speed of the pump can drastically reduce the power that is consumed. Below are some of the major benefits of running the pump at lower speeds.

#### **Benefits of running at low speeds**

- Save electricity and money
- Improved filtration – the filter can often remove smaller particles when the water moves slower
- Quiet operation
- Reduced Total Dynamic Head – less stress on equipment (e.g. filter) which can lengthen equipment life

**When determining the speed(s) to operate your pump, you must also take into account the minimum requirements for proper sanitation and equipment/water feature functionality.**

It is recommended you filter (“turnover”) all the water in the pool at least once every 24 hours. Check with local requirements for the minimum turnover rate. Running the pump at a lower speed may require running the pump for a longer period of time in order to meet the turnover requirements for proper sanitation.

Equipment such as heaters, skimmers, and chlorinators require minimum flows to operate correctly. Refer to individual equipment manuals for specific flow requirements.

After setting the pump speed(s), it is recommended you check that all other equipment/water features are functioning as intended. For example, when running at a low speed for daily filtration, verify water is adequately flowing over the skimmer weirs. Operate the pump at higher speeds for the shorter periods of time needed to operate a heater, water feature, etc.

### 4. Installation and Wiring

 **WARNING** – This product should be installed and serviced only by a qualified professional.

#### 4.1. Pump Location

Locate pump as close to pool as practical and run suction lines as direct as possible to reduce friction loss. Suction lines should have continuous slope upward from lowest point in line. Joints must be tight (but not over-tightened).

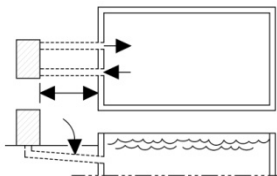

Suction line diameter must equal or be larger than the discharge line diameter.

Though the pump is designed for outdoor use, it is advised to place pump and filter in the shade to shield them from continuous direct heat. Select a well-drained area that will not flood when it rains. Do NOT install pump and filter in a damp or non-ventilated location. Keep motor clean. Pump motors require free circulation of air for cooling.

USE ONLY HAYWARD GENUINE REPLACEMENT PARTS



#### 4.2. Pump Mounting

Install pump on a level concrete slab or other rigid base to meet all local and national codes. Secure pump to base with screws or bolts to further reduce vibration and stress on pipe or hose joints. The base must be level, rigid, and vibration free.

Pump mount must:

- Allow pump inlet height to be as close to water level as possible.
- Allow use of short, direct suction pipe (to reduce friction losses).
- Allow for valves in suction and discharge piping.
- Be protected from excess moisture and flooding.
- Allow adequate access for servicing pump and piping.

#### 4.3. Pipe Sizing Chart

MAXIMUM RECOMMENDED SYSTEM FLOW RATE BY PIPE SIZE		
Pipe Size in. [mm]	Maximum Flow Rate GPM [LPM]	Minimum Straight Pipe Length "L" in. [mm] *
1 ½" [50]	45 [170]	7 ½" [190]
2" [63]	80 [300]	10" [254]
2 ½" [75]	110 [415]	12 ½" [317]
3" [90]	160 [600]	15" [381]

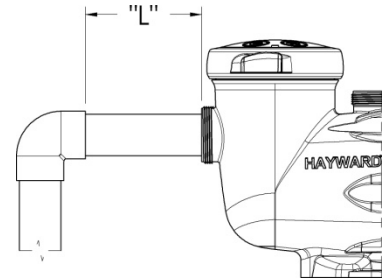

**Note:** It is recommended that a minimum length of straight piping (shown as "L" in above diagram), equivalent to 5 pipe size diameters, be used between the pump suction inlet and any plumbing fittings (elbows, valves, etc.).

**When installing the 2.70 THP VS pump family, care should be taken to ensure proper pipe and equipment sizing to handle the maximum flow required. It is recommended to set the maximum speed in order to not exceed the maximum flow rate. See section 6.6 item #7.**



**WARNING – Hazardous Pressure.** Pumps, filters, and other equipment/ components of a swimming pool filtration system operate under pressure. Incorrectly installed and/or improperly tested filtration equipment and/or components may fail resulting in severe personal injury or death.

#### 4.4. Plumbing

1. Use PTFE tape to seal threaded connections on molded plastic components. All plastic fittings must be new or thoroughly cleaned before use. NOTE - Do NOT use Plumber's Pipe Dope as it may cause cracking of the plastic components. When applying PTFE tape to plastic threads, wrap the entire threaded portion of the male fitting with one to two layers of tape. Wind the tape clockwise as you face the open end of the fitting, beginning at the end of the fitting. The pump suction and outlet ports have molded-in thread stops. Do NOT attempt to force hose connector fitting past this stop. It is only necessary to tighten fittings enough to prevent leakage. Tighten fitting by hand and then use a tool to engage fitting an additional 1 ½ turns. Use care when using PTFE tape as friction is reduced considerably; do NOT over-tighten fitting or you may cause damage. If leaks occur, remove connector, clean off old PTFE tape, re-wrap with one to two additional layers of PTFE tape, and re-install connector.
2. Fittings (elbows, tees, valves, etc.) restrict flow. For better efficiency, use the fewest possible fittings. Avoid fittings that could cause an air trap. Pool and spa fittings MUST conform to the International Association of Plumbing and Mechanical Officials (IAPMO) standards.

USE ONLY HAYWARD GENUINE REPLACEMENT PARTS

#### 4.5. Electrical



**WARNING** – All electrical wiring MUST conform to local codes, regulations, and the National Electric Code (NEC).

**WARNING** – Ground and bond pump before connecting to electrical power supply. Failure to ground and bond pump can cause serious or fatal electrical shock hazard. Do NOT ground to a gas supply line. To avoid dangerous or fatal electrical shock, turn OFF power to pump before working on electrical connections. Fire Hazard - match supply voltage to pump nameplate voltage. Insure that the electrical supply available agrees with the pump's voltage, phase, and cycle, and that the wire size is adequate for the amps rating and distance from the power source. Use copper conductors only.

#### 4.6. Electrical Specs

Refer to motor nameplate for voltage and current ratings. Use copper conductors only. For indoor & outdoor use. Connect pump to a 15 amp branch circuit for 230VAC or a 20 amp branch circuit for 115VAC in accordance with local codes, regulations, and the National Electric Code (NEC). A disconnecting means located at least 5 ft. from the inside wall of the pool, spa, or hot tub must be provided.

#### 4.7. Voltage

Voltage at pump MUST NOT be more than 10% above or below nameplate rated voltage, or components may overheat, causing overload tripping and reduced component life. If voltage is less than 90% or more than 110% of rated voltage when pump is running at full load, consult the power company.

#### 4.8. Grounding and Bonding

1. Install, ground, bond, and wire pump in accordance with local or national electrical code requirements.
2. Permanently ground pump. Use green ground terminal provided under access plate; use size and type wire required by code. Connect ground terminal to electrical service ground.
3. Bond pump to pool structure. Bonding will connect all metal parts within and around the pool with a continuous wire. Bonding reduces the risk of a current passing between bonded metal objects, which could potentially cause electrical shock if grounded or shorted. Reference NEC codes for all wiring standards including, but not limited to, grounding, bonding and general wiring procedures.
4. Use a solid copper conductor, size 8 or larger. Run wire from external bonding lug to reinforcing rod or mesh. Connect a No. 8 AWG (8.4 mm<sup>2</sup>) [No. 6 AWG (13.3 mm<sup>2</sup>) for Canada] solid copper bonding wire to the pressure wire connector provided on the motor housing and to all metal parts of swimming pool, spa, or hot tub, and to all electrical equipment, metal piping (except gas piping), and conduit within 5 ft. (1.5 m) of inside walls of swimming pool, spa, or hot tub.

#### 4.9. Wiring

**WARNING** – All electrical wiring MUST conform to local codes, regulations, and National Electric Code (NEC)

1. Pump MUST be permanently connected to circuit. If other lights or appliances are also on the same circuit, be sure to add their amp loads before calculating wire and circuit breaker sizes. Use the circuit breaker as the master On-Off switch.
2. If this VS pump is being used to replace an existing pump that was controlled by a separate mechanical time clock, it should be connected directly to the line power supply, bypassing the time clock. The time clock can then be used to power other equipment (such as a heater, heat pump, or booster pump) that requires the filter pump to be operating when used. If the time clock is used in this manner, it should be set to power the equipment during a time cycle when the VS pump is operating at an appropriate flow rate to operate the other equipment, as defined by the timers set in the Timer Menu. See section 6.7

#### 4.10. Remote Control Wiring/Operation

The 2.70 THP VS pump family can be controlled in a wide variety of ways as described below:

1. They can operate by themselves in Stand-Alone Mode using their built-in programmable timers.
2. They can also be controlled from third party controls (i.e. another manufacturer's control) and Hayward controls that are not software compatible using relay contacts. See section 5.3 for more information regarding connecting this pump and third party/non-software compatible Hayward controls.
3. They can communicate with and be controlled by Hayward pool and spa controls. See section 5.4 for more information regarding connecting this pump and Hayward pool and spa controls.

#### 4.11. SVRS Notes (Only applicable to SVRS pump models)

The Safety Vacuum Release System (SVRS) model is designed to provide an additional layer of protection against body suction entrapment. It complies with **ASME/ANSI A112.19.17-2002 SVRS** standard.

1. SVRS devices shall only be installed in conjunction with an **ASME A112.19.8** suction fitting, or a 12 in. x 12 in. (305 mm x 305 mm) drain grate or larger, or an approved channel drain at each suction outlet or drain outlet.
2. Check valves and hydrostatic valves shall not be used in suction systems protected by SVRS devices.

**⚠ WARNING** – The presence of a hydrostatic valve in the suction piping has been shown to prolong the high vacuum present at the drain, even though the drain was protected by an SVRS device.

3. All SVRS devices shall be factory set or field adjusted to site-specific hydraulic conditions. Once installed, the system shall be tested by simulating an entrapment event.
4. A ball, butterfly, or sliding gate valve shall be installed within 2 ft. (0.6 m) upstream from the SVRS (between the SVRS and the protected suction outlet), or a test mat shall be used to cover the suction outlet to simulate an entrapment event. There shall be three simulated entrapment tests conducted to verify proper adjustment and operation of the device.
5. One SVRS device shall be installed for each circulating pump plumbed directly to the suction outlet(s) without the use of valves that could isolate the SVRS device from the suction system.

#### 4.12. Digital Control Interface Orientation

The Digital Control Interface can be rotated to any of four desired positions after installation by loosening the two screws securing the user interface to the motor drive, lifting the user interface and rotating it to the desired position, and tightening the two screws in the new position.

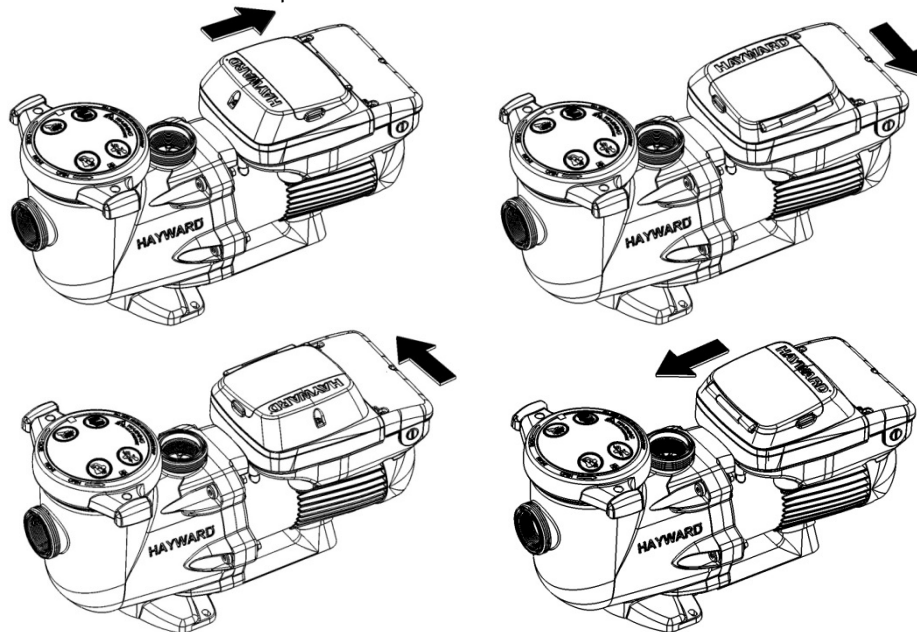

USE ONLY HAYWARD GENUINE REPLACEMENT PARTS

### 4.13. Interface Wall Mounting

The interface can also be wall mounted using the parts supplied in the optional wall mount kit using the following procedure.

1. **TURN OFF THE ELECTRICAL POWER AT THE CIRCUIT BREAKER.**
2. Loosen the two screws securing the user interface to the motor drive and remove the user interface. (Figure 4.13-1)
3. Disconnect the short cable that extends out from the motor drive to the user interface. (Figure 4.13-1)
4. Loosen the three screws securing the wiring compartment cover to the motor drive and remove the cover to gain access to the drive wiring compartment.
5. Unplug the short cable from the RS485 terminal block on the low voltage PCB.
6. Mount the wall mount plate, SP3200DR10, in the desired location. (Figure 4.13-3)
7. Connect the interface cable as shown in the Wall Mounted Digital Control Interface Wiring diagram shown in section 5.4 to the second motor drive RS485 terminal block and user interface PCB. Use multi-conductor, jacketed cable suitable for the installation location. The cable must be routed through one of the left side conduit openings on the motor drive and through the slot provided on the backside of the wall mount plate, SP3200DR10. Use a liquid tight cordgrip, appropriately sized for the cable being used, to seal the conduit opening. Cable used may be up to 500 feet in length. (Figure 4.13-3)
8. Mount the user interface to the wall mount plate, SP3200DR10, using the two screws. (Figure 4.13-3)
9. Reinstall the wiring compartment cover, taking care to make sure it is properly aligned with the motor drive, and tighten the three screws to secure.
10. Install the blank cover, SP3200DR9, on the motor drive in the desired orientation. This cover is important to protect internal electronics. (Figure 4.13-2)
11. Apply power to the system and resume normal operation.

The following diagrams illustrate the interface wall mounting procedure.

**Figure 4.13-1: Removing the Digital Control Interface for Wall Mounting**

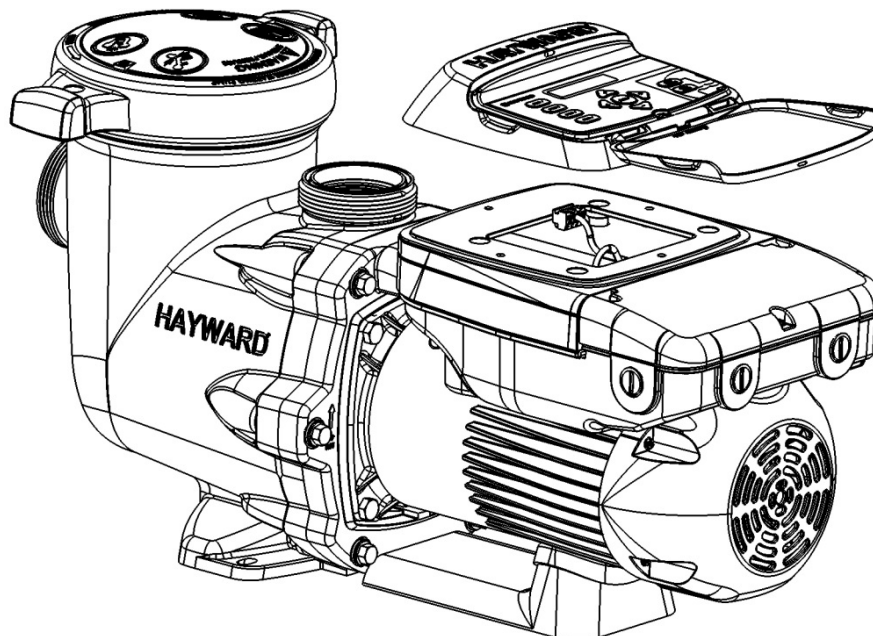

USE ONLY HAYWARD GENUINE REPLACEMENT PARTS

**Figure 4.13-2: Adding the Blank Cover**

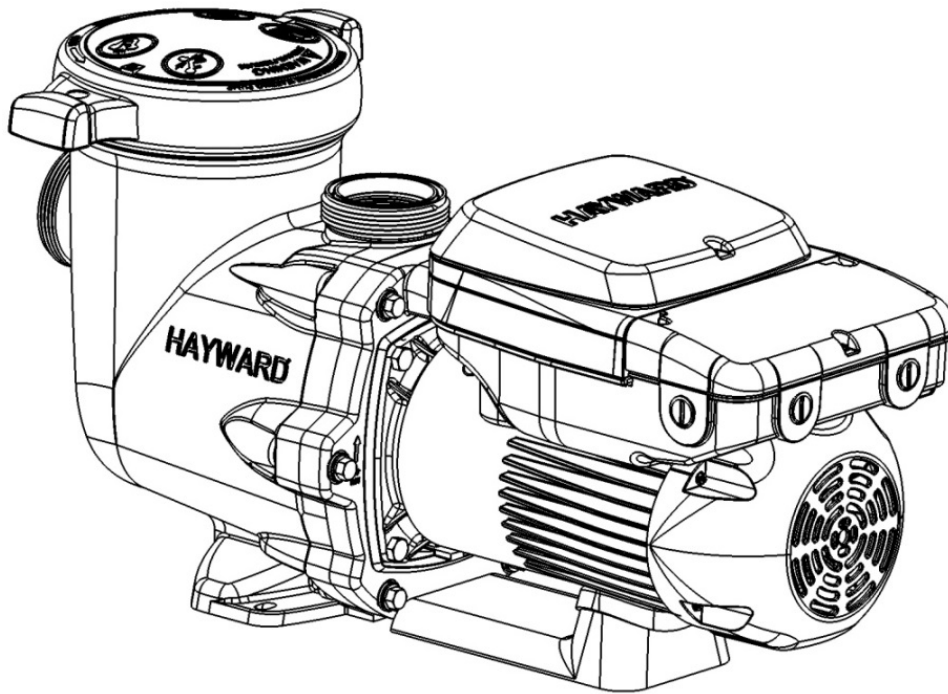

**Figure 4.13-3: Wall Mounting the Interface**

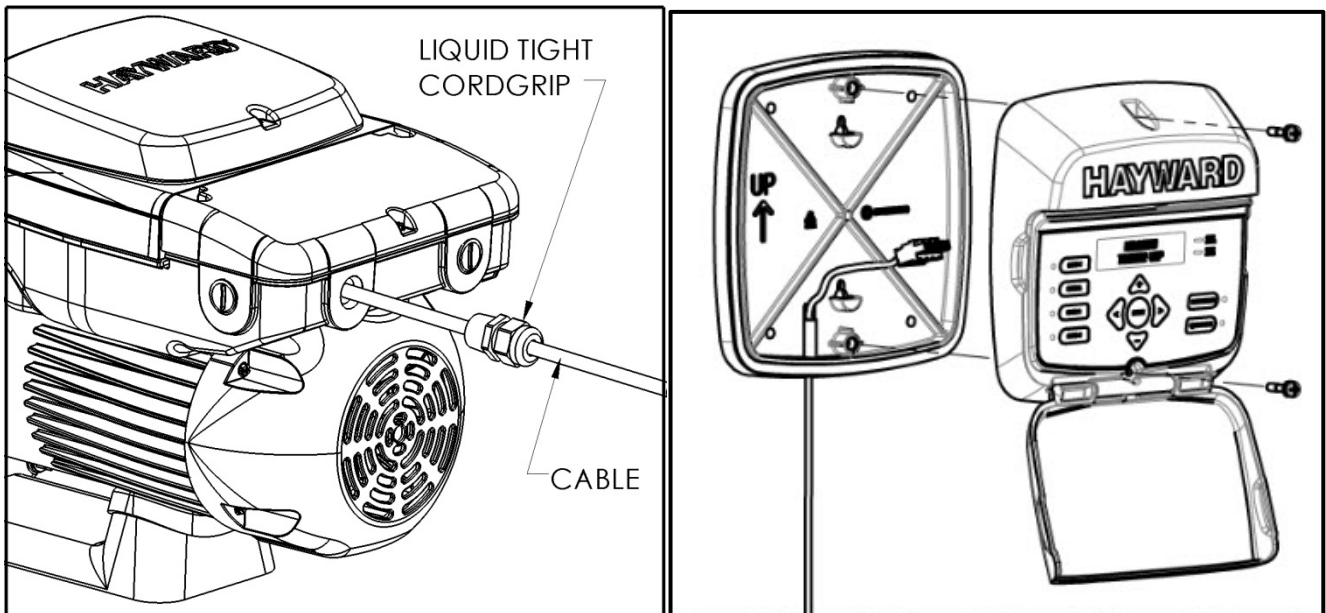

USE ONLY HAYWARD GENUINE REPLACEMENT PARTS

## 4.14. Installation Procedure

Please review sections 4.1 through 4.13 before continuing with this section.

1. **TURN OFF THE ELECTRICAL POWER AT THE CIRCUIT BREAKER.**
2. Loosen the three screws securing the wiring compartment cover and remove the cover to gain access to the drive wiring compartment.
3. Connect line power supply wiring to the terminals and ground screw as shown in the Input Power Wiring diagram. Wiring must be routed through one of the right side conduit openings. See section 5.1 for diagram.
4. If the pump will be controlled using a Hayward pool control, connect the provided three-conductor cable as shown in the Hayward Automation Control Wiring diagram. See section 5.2.
5. If the pump will be controlled using relay contacts from an external control, connect the digital input terminals to the relay contacts as shown in the External Relay Speed Control Wiring diagram. See section 5.3.
6. If the installation will use the remote stop feature of the drive, connect the digital input terminals to the remote stop switch as shown in the Remote Stop Wiring diagram. See section 5.5.
7. Wiring for remote control and/or remote stop functions must be routed through one of the left side conduit openings. Use a multi-conductor, jacketed cable suitable for the installation location. Use a liquid tight cordgrip, appropriately sized for the cable being used, to seal the conduit opening.
8. Connect the pump to the pool bonding system using 8AWG (6AWG for Canada) wire. A lug for bonding is provided on the outside of the drive enclosure.
9. After all electrical connections have been made, replace the wiring compartment cover, taking care to make sure it is properly aligned with the motor drive, and tighten the three screws to secure.

**Note:** The wiring compartment cover **must** be installed properly to provide environmental protection for the wiring compartment.

10. Apply power to the system, and proceed to “Configuration Menu”, section 6.6, or see section 5.2 for details regarding Hayward automation control.

## 5. Wiring Diagrams

### 5.1. Input Power Wiring (Required)

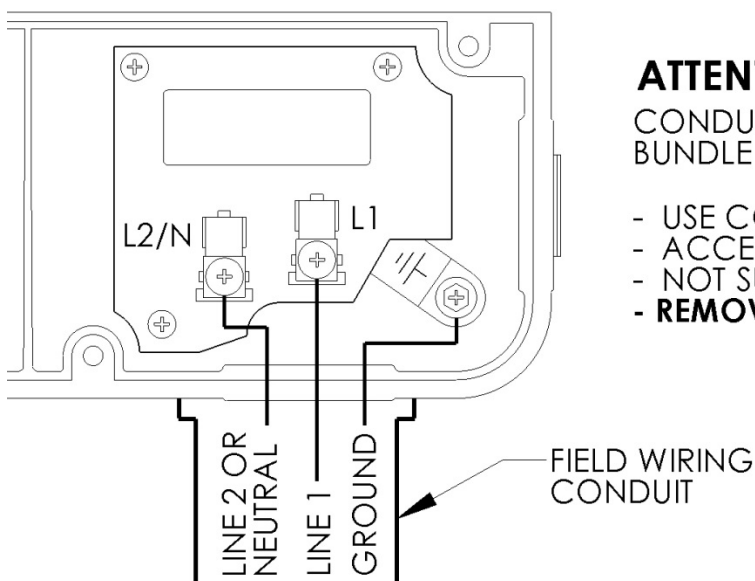

**Figure 5.1-1**

**ATTENTION:** ROUTE WIRING DIRECTLY FROM FIELD CONDUIT TO TERMINAL BLOCK AS SHOWN. DO NOT BUNDLE EXCESS WIRING INSIDE DRIVE ENCLOSURE.

- USE COPPER CONDUCTORS ONLY
- ACCEPTABLE FOR FIELD WIRING
- NOT SUITABLE FOR USE WITH RIGID METAL CONDUIT
- **REMOVE TEST LEADS PRIOR TO INSTALL**

USE ONLY HAYWARD GENUINE REPLACEMENT PARTS

## 5.2. Hayward Automation Control Wiring (Optional, for remote control of pump speed)

**Note:** For software compatible Hayward controls only. Existing user interface wiring connection (if present) should be unplugged and second terminal block connector should be used to make wiring connections shown below.

**Figure 5.2-1**

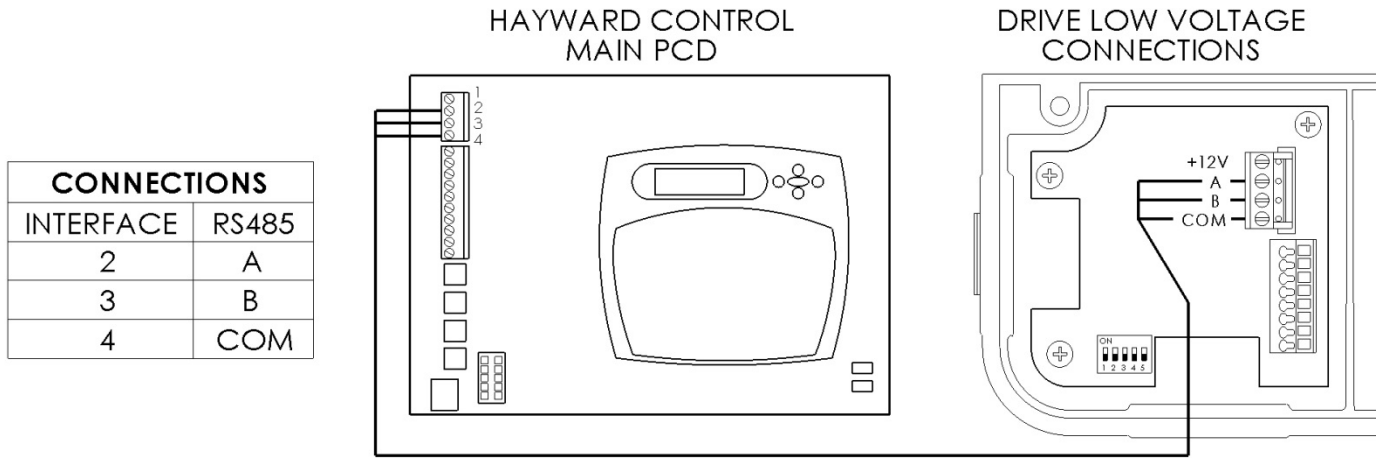

This pump can communicate with and be controlled by Hayward pool controls such as OmniLogic™, ProLogic®, E-Command® 4, and OnCommand®. Minimum software revision requirements: OmniLogic R1.0.0, ProLogic 3.00, OnCommand 1.00, E-Command 2.65, E-Command 4 2.80, AquaLogic 2.65, and AquaPlus 2.65. To determine Hayward control software revision, consult the appropriate Hayward pool control installation manual or visit our website at [www.haywardpool.com](http://www.haywardpool.com). Connection wire must be rated for a minimum of 300V, and may be up to 500 feet in length. Use removable 4-position terminal block connector for wiring connection to motor drive PCB, taking care to note the wire colors and corresponding numbers next to the connectors. **Terminal block must be installed with screws facing up to ensure proper connection.**

**⚠ ATTENTION – THIS PUMP CAN ALSO BE SET SO THAT IT WILL CONTINUE RUNNING IN THE EVENT OF COMMUNICATION LOSS.** When inputs are activated via wire jumpers, the pump will respond to a communication loss (after a 4 minute delay) as follows:

1. No inputs connected: pump remains stopped
2. INP1 connected: pump runs 3450 rpm for 8 minutes, then 1725 rpm
3. INP2 connected: pump runs 3450 rpm for 8 minutes, then 2600 rpm
4. INP3 connected: pump runs 3450 rpm

See section 5.4 for details regarding input connections (relays would not be used when connecting inputs to set comm loss behavior; use short jumpers in this case). **Note:** Prior to drive comm revision 10.10, pump response was as follows: no inputs connected – pump runs 3450 rpm for 8 minutes then 1725 rpm; INP1 connected – pump runs 3450 rpm for 8 minutes then 2600 rpm; INP2 connected – pump runs 3450; INP3 connected – pump remains stopped. **Jumpers, if used to set desired behavior in the event of communication loss, need to be installed at initial pump installation.**

When communicating with OmniLogic, the HUA (Hayward Unique Address) is used for communication. For all Hayward controls other than OmniLogic, the pump address must be set using the DIP switches on the drive PCB. To determine which address should be used, consult the appropriate Hayward pool control installation manual, or visit our website at [www.haywardpool.com](http://www.haywardpool.com). Pump addresses are set according to the table on the following page.

### DIP SWITCH STATUS

PUMP ADDRESS	#1	#2	#3	#4	#5
Pool Filter	OFF	OFF	OFF	OFF	OFF
Aux 1 / Spa Filter	OFF	ON	OFF	OFF	OFF
Aux 2	OFF	OFF	ON	OFF	OFF
Aux 3	OFF	ON	ON	OFF	OFF
Aux 4	OFF	OFF	OFF	ON	OFF
Aux 5	OFF	ON	OFF	ON	OFF
Aux 6	OFF	OFF	ON	ON	OFF
Aux 7	OFF	ON	ON	ON	OFF
Aux 8	OFF	OFF	OFF	OFF	ON
Aux 9	OFF	ON	OFF	OFF	ON
Aux 10	OFF	OFF	ON	OFF	ON
Aux 11	OFF	ON	ON	OFF	ON
Aux 12	OFF	OFF	OFF	ON	ON
Aux 13	OFF	ON	OFF	ON	ON
Aux 14	OFF	OFF	ON	ON	ON
Lights Button	OFF	ON	ON	ON	ON

### 5.3. External Relay Speed Control Wiring (Optional, for remote selection of pump speed)

**Note:** For third party controls and Hayward controls that are NOT software compatible.

**Figure 5.3-1**

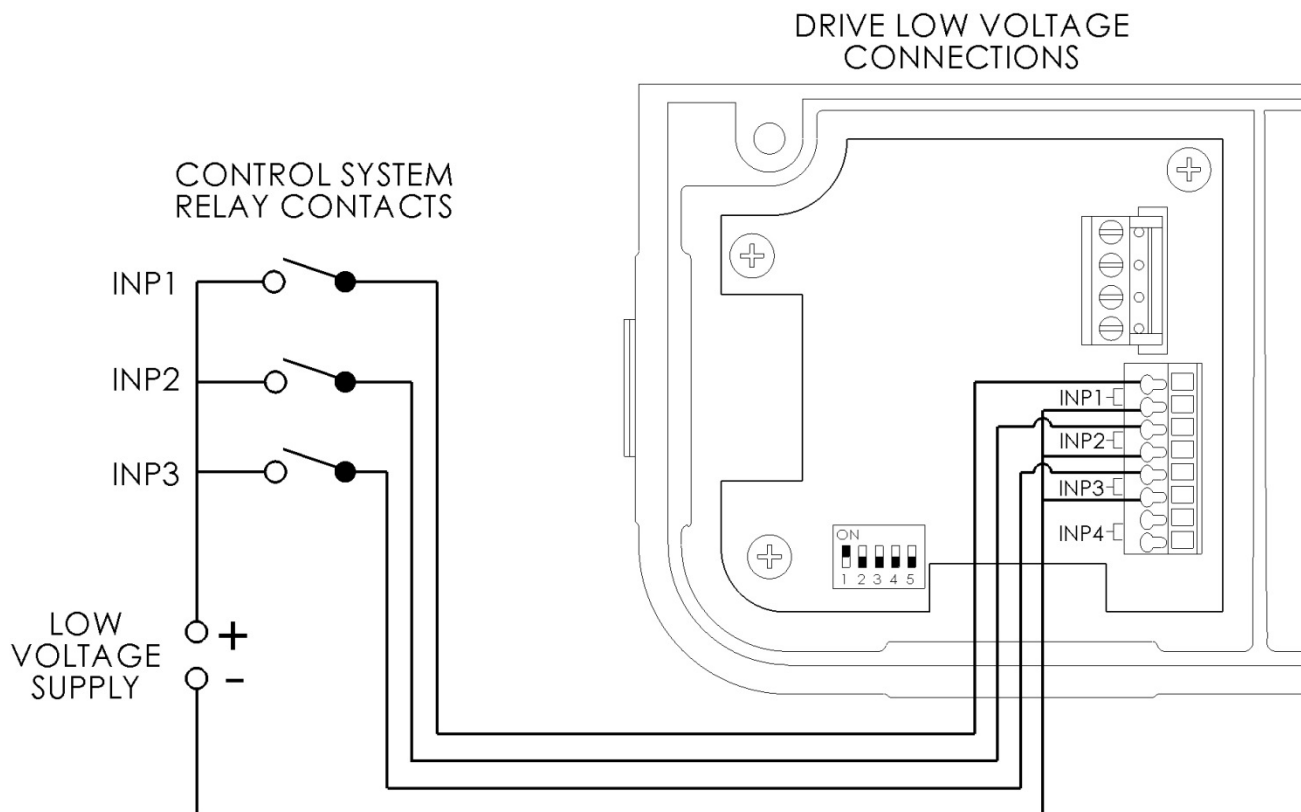

Connection wire must be rated for a minimum of 300V. Inputs are rated to accept a low voltage supply of 18-30 VAC, 9-30 VDC, 50/60 Hz. The "+12V" and "COM" terminals may be used as a low voltage supply, however, these terminals also supply power to the user interface, so care must be taken when connecting to these terminals to ensure proper operation of the user interface. DIP switch #1 must be "ON".

**USE ONLY HAYWARD GENUINE REPLACEMENT PARTS**



This pump can be controlled from third party pool controls as well as Hayward controls that are not software compatible using relay contacts to select the speeds set in the Timer Menu (see section 6.7). In addition to this section you may also consult the applicable pool control installation manual for electrical connection details. Once installed, Remote Control Mode must be set to Relay Control in the pump Configuration Menu (see section 6.6). Preset Speeds 1-4 and Quick Clean are disabled when the pump is remotely controlled. When inputs INP1-3 are activated via the pool control relay contacts, timer speeds 1-8 are selected according to the following table (see section 6.7):

Timer Speed	INP1 Status	INP2 Status	INP3 Status
1	OFF	OFF	OFF
2	ON	OFF	OFF
3	OFF	ON	OFF
4	ON	ON	OFF
5	OFF	OFF	ON
6	ON	OFF	ON
7	OFF	ON	ON
8	ON	ON	ON

**The number of speeds available depends on the number of auxiliary relays used as noted below:**

1. Filter pump relay plus 1 auxiliary relays allows control of 2 speeds
2. Filter pump relay plus 2 auxiliary relays allows control of 4 speeds
3. Filter pump relay plus 3 auxiliary relays allows control of 8 speeds

#### 5.4. Wall Mounted Digital Control Interface Wiring (Optional)

**Figure 5.4-1**

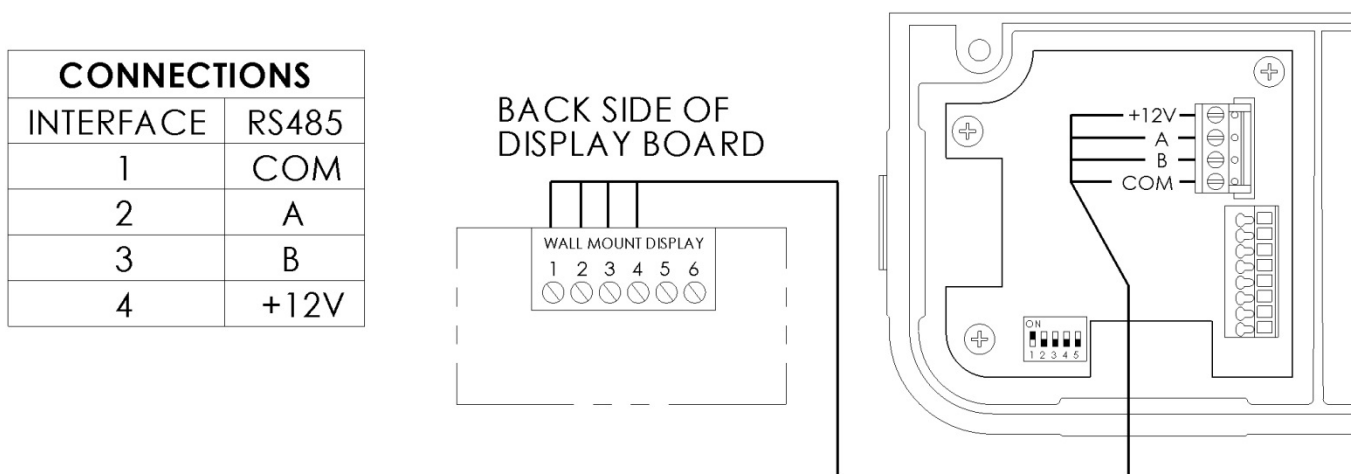

Connection wire must be rated for a minimum of 300V, and may be up to 500 feet in length. Use removable 4-position terminal block connectors for wiring connection to interface and motor drive PCB's taking care to note the wire colors and corresponding numbers next to the connectors. **Terminal block must be installed with screws facing up to ensure proper connection.** DIP switch #1 must be "ON".

## 5.5. Remote Stop Switch Wiring (Optional)

**Figure 5.5-1**

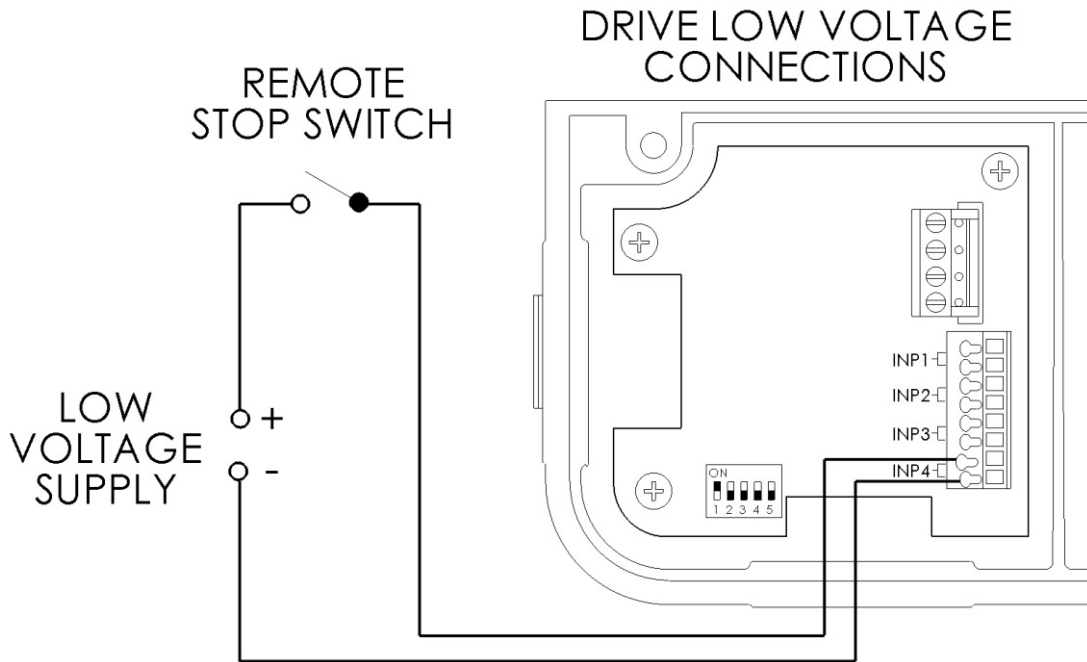

Connection wire must be rated for a minimum of 300V. Switch must be latching type; pump is stopped when circuit is closed. Inputs are rated to accept a low voltage supply of 18-30 VAC, 9-30 VDC, 50/60 Hz. The “+12V” and “COM” terminals may be used as a low voltage supply, however these terminals also supply power to the user interface, so care must be taken when connecting to these terminals to ensure proper operation of user interface. If the “+12V” and “COM” terminals are used, DIP switch #1 must be “ON”.

## 6. Startup & Operation

### 6.1. Prior to Start-Up

If it is necessary to perform a water pressure test prior to initial use to ensure plumbing system is functioning properly, then the following criteria should be maintained for this test:

1. Have a professional perform this test.
2. Ensure all Hayward pump and system components are removed from system prior to performing test.

**⚠ WARNING** – If circulation equipment must remain in the plumbing system during water pressure test, do not apply more than 10 psi pressure to the system. Be sure water pressure has been released, using the filter manual air relief valve, before removing pump strainer cover.

**⚠ WARNING** – All suction and discharge valves **MUST** be OPEN, as well as filter air relief valve (if available) on filter, when starting the circulating pump system. Failure to do so could result in severe personal injury.

## 6.2. Starting/Priming the Pump

Refer to item #10 in section 6.6 for priming time selection.

Fill strainer housing with water to suction pipe level. If water leakage occurs from anywhere on the pump or filter, DO NOT start the pump. If no leakage occurs, stand at least 10 feet from pump and/or filter and proceed with starting the pump.

 **WARNING** – Return to filter to close filter manual air relief valve when a steady stream of water (not air or air and water) is discharged from valve. Failure to do so could result in severe personal injury.

 **ATTENTION** – **NEVER OPERATE THE PUMP WITHOUT WATER.** Water acts as a coolant and lubricant for the mechanical shaft seal. NEVER run pump dry. Running pump dry may damage seals, causing leakage, flooding, and voids warranty. Fill strainer housing with water before starting motor.

 **ATTENTION** – Do NOT add chemicals to pool/spa system directly in front of pump suction. Adding undiluted chemicals may damage pump and voids warranty.

 **ATTENTION** – Before removing strainer cover:

1. STOP PUMP before proceeding.
2. CLOSE VALVES in suction and outlet pipes.
3. RELEASE ALL PRESSURE from pump and piping system using filter manual air relief valve. See filter owner's manual for more details.
4. Remove strainer cover and fill strainer housing with water.
5. Clean and lubricate strainer cover O-ring with "Jack's 327" if necessary.
6. Replace strainer cover on strainer housing.
7. OPEN VALVES in suction and outlet pipes.

**Note: Tighten strainer cover lock ring by hand only (no wrenches).**

Turn on power and wait for pump to prime, which can take up to ten (10) minutes. Priming time will depend on vertical length of suction lift and horizontal length of suction pipe. If pump does NOT prime within 10 minutes, stop motor and determine cause. Be sure all suction and discharge valves are open when pump is running. See Troubleshooting Guide.

### 6.3. User Interface Summary

**Figure 6.3-1**

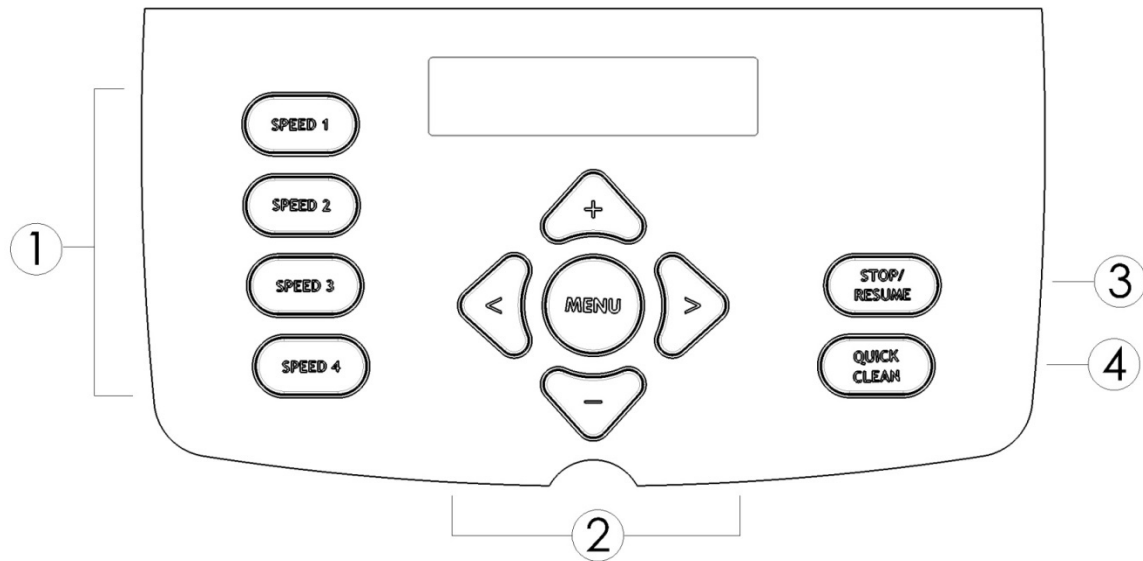

1. **Preset Speeds:** Buttons labeled SPEED 1 thru SPEED 4 can be used to run the pump at a predetermined speed until the next programmed timer is scheduled to begin. Preset Speed settings can be quickly updated using the + and - arrow buttons to change the speed and then pressing the > button to save the new speed setting if desired.
  - a. **Default Speeds:**
    - Speed 1: 1150 rpm
    - Speed 2: 1725 rpm
    - Speed 3: 2300 rpm
    - Speed 4: 2875 rpm
2. **Menu/navigation buttons:** The MENU button will scroll through the setup menus when pressed. The < and > arrow buttons are used to move between displays and to select parameters to edit, and the + and - arrow buttons are used to change parameters.
3. **Stop/Resume:** This button is used to stop the pump to allow strainer basket cleaning, etc. When this button is pressed, the pump will remain stopped until the button is pressed a second time to resume normal operation.
4. **Quick Clean:** QUICK CLEAN is a mode intended for use when the pool will be cleaned with a suction side vacuum. While in Quick Clean mode, for SVRS pump models, the SVRS feature is disabled for 60 minutes to prevent nuisance tripping during cleaning. Users will be prompted to check and verify that all bathers are out of the pool during this time.

## 6.4. Menu Outline

1. **Configuration Menu** (see section 6.6 for basic product configuration)
  - a. Display Language
  - b. Set Day and Time
  - c. Speed Selection
  - d. Max Allowed Speed
  - e. Min Allowed Speed
  - f. Prime Duration
  - g. Remote Control Mode
  - h. SVRS Restart (if applicable)
  - i. Low Temp Operation
  - j. Low Temp Setting
  - k. Password Protection
  - l. Password Timeout
  - m. Set Password
2. **Timer Menu** (see section 6.7 to program the 8 speeds with timer functions)
  - a. Rename Timer “X” (where “X” equals 1 through 8)
  - b. Pump Speed for Timer “X” (where “X” equals 1 through 8)
  - c. Start/Stop Time for Timer “X” (where “X” equals 1 through 8)
  - d. Choose Days for Timer “X” (where “X” equals 1 through 8)
3. **Preset Speed Setup Menu** (see section 6.8 to program the 4 preset speeds)
  - a. Speed “X” Name (where “X” equals 1 through 4)
  - b. Speed “X” Speed (where “X” equals 1 through 4)
4. **Diagnostics Menu** (see section 6.9 to view product diagnostic information)
  - a. Display Firmware Revision
  - b. Drive Serial Number
  - c. Motor Drive Firmware Revisions
  - d. SVRS Revision (if applicable)
  - e. Event Log (if applicable)

## 6.5. Initial startup

After plumbing and wiring are complete, the variable speed drive must be configured prior to use. When power is applied to the drive for the first time, the following informational screens are displayed.

	<u>Screen</u>	<u>Comments</u>
1.	<b>Hayward Variable Speed Pump</b>	
2.	<b>Thursday      1:27p 1725rpm      380 Watts</b>	
3.	<b>Timer 1 timer will end at 11:45p</b>	

**Note:** Speeds can be selected at this time to temporarily run the pump, however, it is recommended that the drive configuration and timers be set according to individual installation site requirements (see section 6.7 for more details). At this point, pressing the MENU button will select the Configuration Menu.

## 6.6. Configuration Menu

	<u>Screen</u>	<u>Buttons Used</u>	<u>Comments</u>
1.	Configuration Menu Locked	< >	Press & hold < and > buttons for several seconds to unlock Configuration Menu
2.	Configuration Menu press > to enter	< >	Use > to enter Configuration Menu
3.	Press +/- to change or > view next item		
4.	Display Language English	+ - < >	Select language for all displayed messages Move to next menu item
5.	Time: Th 1:27PM + change or > skip	+ - < >	Use + to change clock setting Use > if clock is correct
6.	Set Day and Time Thursday 1:27p	+ - < >	Adjust day/time setting Move to next selection, then to next menu item
7.	Speed Selection rpm	+ - < >	Select whether to display speed in rpm (Revolutions per Minute) or % of full speed Move to next menu item
8.	Max allowed speed 3450 (600-3450rpm)	+ - < >	Set maximum running speed of pump Move to next menu item
9.	Min allowed speed 600 (600-3450rpm)	+ - < >	Set minimum running speed of pump Move to next menu item
10.	Prime Duration 8:00 minutes	+ - < >	Select pump prime duration Move to next menu item
<b>Note:</b> User may set the pump to prime at the maximum allowed speed for 0-15 minutes in 30 second increments.			
11.	Remote Control Mode Stand Alone	+ - < >	Select Stand Alone or Relay Control Move to next menu item
<b>Note:</b> See section 5.3 for more detail.			
12.	SVRS Restart Automatic	+ - < >	Set SVRS Restart to Automatic or Manual Move to next menu item

**Note:** For SVRS pump models, the SVRS feature may be set to restart automatically or manually after a trip event occurs. When set to Automatic, the pump will resume normal operation after 15 minutes, or the user may manually restart the pump prior to the automatic restart by pressing the Stop/Resume button. When set to Manual, the pump will resume normal operation ONLY after the user presses the Stop/Resume button.

USE ONLY HAYWARD GENUINE REPLACEMENT PARTS

	<u>Screen</u>	<u>Buttons Used</u>	<u>Comments</u>
13.	<b>Low Temp Operation Disabled</b>	+ - < >	Enable or Disable Low Temp Operation Move to next menu item
14.	<b>Low Temp Setting 4°C (39.2°F)</b>	+ - < >	Set temperature to activate Low Temp Operation Move to next menu item

**Note:** When the pump is stopped and the ambient temperature drops below the operation temperature set point, the pump will prime and then run at the Max allowed speed setting for 8 hours. Low temperature operation is *not* active when the pump is being remotely controlled. **Low temperature operation is NOT intended to protect the pump, system plumbing, or pool from freezing.** If Low Temp Operation is disabled, the temperature setting screen is not shown.

15.	<b>Password Protection Disabled</b>	+ - < >	Use to enable or disable password protection Move to next menu item
16.	<b>Password Timeout 0:15</b>	+ - < >	Use to set password timeout Move to next menu item

**Note:** This sets the amount of time from the last button activation after the system has been unlocked to the point where the system becomes locked again.

17.	<b>System Password + change or &gt; skip</b>	+ - < >	Use change system password if desired Move to next menu item
18.	<b>Set Password 0 ____</b>	+ - < >	Use to set selected password character Move to next password character/next menu item
19.	<b>Confirm Password 0 ____</b>	+ - < >	Use to set selected password character Move to next password character/next menu item

**Note:** If the new password is not confirmed correctly, then the user will be prompted again to confirm the password. If a mistake is made when entering the password, pressing Stop/Resume will cancel the action.

After a password has been set, follow the procedure below to unlock the system from the Home screen.

20.	<b>System Locked Password: 0 ____</b>	+ - < >	Use to set selected password character Move to next password character
-----	-------------------------------------------	------------	---------------------------------------------------------------------------

**Note:** When password protection is enabled and the timeout has elapsed, the user will be prompted to enter the password to unlock the display when any of the display buttons (other than Stop/Resume) are selected. The user may use Stop/Resume to stop the pump and resume normal operation without having to enter the password. The factory default password is 1234. If the password has been changed, it may be reset to factory default by pressing and holding the Speed 1 and Speed 4 buttons at the same time while powering on the drive, or by resetting all parameters in the Configuration Menu. If a mistake is made when entering the password, pressing Stop/Resume will cancel the action. If the pump is being controlled by a Hayward or third party pool control, the pump display can be locked by the password, however, the pump will respond to any and all commands being sent from the pool control.

	<u>Screen</u>	<u>Buttons Used</u>	<u>Comments</u>
21.	Reset all settings? + yes or - no	+ - < >	Use + to reset to factory default settings Use > to skip reset
22.	Are you sure? + yes or - no	+ - < >	Confirm reset of all parameters Move to next menu item
23.	Use Timers Menu to set daily timers		

## 6.7. Timer Menu

	<u>Screen</u>	<u>Buttons Used</u>	<u>Comments</u>
1.	Timer Menu Press > to enter	< >	Use > to enter Timer Menu
2.	Press +/- to change or > view next item		
3.	Timer 1 1725rpm 12:00a to 11:45p		
4.	Press + to change or > next timer	+ - < >	Use + to change displayed timer Use > to skip to next timer
5.	T1: Timer 1 +/- rename; speed >	+ - < >	Use + to rename timer Use > to set motor speed for timer
6.	Timer 1 1725rpm +/- adjust; times >	+ - < >	Use to set speed for timer Use > to set start/stop time
7.	Timer 1 1725rpm 8:00a to 6:00p	+ - < >	Use to set start/stop time for timer Use > to choose days of operation for timer
8.	Choose Days 7D 7 days a week	+ - < >	Use to choose days of operation for timer Move to next menu item

**Note:** When start/stop times are set to be the same, the timer is deactivated. Each timer can be set to run on specific days of the week. Options are to run 7 days per week, 5 days per week (Monday thru Friday), or on a single day (Monday thru Sunday). Each timer is set up in this same manner. If the timers are set up such that their run times overlap, the timers will run in priority from Timer 1 to Timer 8. In other words, if Timer 1 is set to run from 8:00 am to 12:00 pm, and Timer 2 is set to run from 10:00 am to 2:00 pm, the pump will run Timer 1 from 8:00 am to 12:00 pm, and will then switch to run Timer 2 until 2:00 pm. Default setting for Timer 1 is to start at 12:00 am, and end at 11:45 pm. When Remote Control Mode is set to Relay Control, the speed for Timer 1 may be set to 0 rpm to allow the pump to be stopped without having to remove power.

USE ONLY HAYWARD GENUINE REPLACEMENT PARTS



## 6.8. Preset Speed Setup Menu

	<u>Screen</u>	<u>Buttons Used</u>	<u>Comments</u>
1.	Speeds Menu Press > to enter	< >	Use > to enter Speeds Menu
2.	Press +/- to change or > view next item		
3.	Speed 1 1150rpm		
4.	Press + to change or > next speed	+ - < >	Use to change displayed speed Move to next menu item
5.	S1: Speed 1 +/- rename; > speed	+ - < >	Use to rename speed Move to next menu item
6.	Speed 1 1725rpm +/- adjust	+ - < >	Use to set motor speed for displayed speed Move to next menu item

**Note:** Preset Speed settings can also be quickly updated without entering the Speeds Menu using the + and - arrow buttons to change the speed and then pressing the > button to save the new speed setting.

## 6.9. Diagnostic Menu

	<u>Screen</u>	<u>Buttons Used</u>	<u>Comments</u>
1.	Diagnostic Menu Press > to enter	< >	Use > to enter Diagnostic Menu and toggle between displays
2.	Press > to view next item		
3.	Display Revision 2.00		Displays firmware version of the display PCB.
4.	Drive Serial Number 3581200032		Displays motor drive serial number.
5.	Comm Rev: 10.10 Drv Rev: 2.00.65		Displays firmware revisions of the motor drive and drive interface PCB's.
6.	SVRS Revision: 1:00 Status: Monitoring		Displays revision and status of integrated SVRS, if applicable.
7.	Event log Press > to view	< >	Use > to view event log

**Note:** For troubleshooting purposes, the Event Log will record the last twenty error/trip conditions and/or status messages, as well as the amount of time that has elapsed since the condition occurred. See section 11.2 for more detail.

## 6.10. Stop/Resume

	<u>Screen</u>
1.	Pump is stopped; press Stop/Resume
2.	again to resume normal operation

**Note:** When Stop/Resume is pressed at any time during normal operation, the above message will be displayed. The pump will stop within several seconds, and will remain stopped until Stop/Resume is pressed a second time, at which point the pump will resume normal operation.

## 6.11. Quick Clean

### Screen

1. 

SVRS inactive in  
Quick Clean mode
2. 

No bathers in water  
during Quick Clean
3. 

Bathers in water?  
+ yes or - no

**Note:** For SVRS pump models, the SVRS feature is disabled during Quick Clean mode. When Quick Clean is pressed, the above message is displayed to alert the user that SVRS is disabled, and that all bathers should exit the pool during Quick Clean. If bathers are in the water, pressing + will return the pump to normal operation. If bathers are not in the water, pressing – will allow the pump to run in Quick Clean mode, where it will run at the Max allowed speed set in the Configuration Menu for 60 minutes. When Quick Clean is selected for non-SVRS pump models, the pump will immediately proceed to Quick Clean mode.

4. 

SVRS Inactive  
Quick Clean running
5. 

SVRS Inactive  
3450 rpm for 60 min;
6. 

SVRS Inactive  
press Resume to end

**Note:** The above message will be displayed while Quick Clean is running. Quick Clean mode runs at the Max allowed speed and expires after 60 min, and it may be cancelled early by pressing the Stop/Resume button, at which time the pump would return to normal operation. Quick Clean can be extended up to 360 minutes with additional presses of the Quick clean button. For non-SVRS pump models, the SVRS Inactive message will not be shown.

## 6.12. Remote Stop

### Screen

1. 

Remote Stop  
is engaged

**Note:** The above message will be displayed when an installed remote stop switch is activated. The pump will remain stopped until the remote stop switch is deactivated. See section 5.5 for more detail.

# 7. Maintenance

- Clean strainer basket regularly. Do NOT strike basket. Inspect cover gasket regularly and replace as necessary.
- Hayward pumps have self-lubricating motor bearings and shaft seals. No lubrication is necessary.
- Keep motor clean. Keep motor air vents free of obstructions to avoid damage. Do NOT use water to hose off motor.
- Occasionally, shaft seals must be replaced, due to wear or damage. Replace with genuine Hayward seal assembly kit. See “Shaft Seal Change Instructions” in this manual.

USE ONLY HAYWARD GENUINE REPLACEMENT PARTS

## 8. Storage / Winterization



**WARNING – Separation Hazard.** Do not purge the system with compressed air. Purging the system with compressed air can cause components to explode, with risk of severe injury or death to anyone nearby. Use only a low pressure (below 5 PSI), high volume blower when air purging the pump, filter, or piping.



**ATTENTION** – Allowing the pump to freeze with water in it will void the warranty.



**ATTENTION** – Use ONLY propylene glycol as antifreeze in your pool/spa system. Propylene glycol is non-toxic and will not damage plastic system components; other anti-freezes are highly toxic and may damage plastic components in the system.

Drain all water from pump and piping when expecting freezing temperatures or when storing pump for a long time (see instructions below). Gravity drain system as far as possible.

Keep motor dry and covered during storage. To avoid condensation/corrosion problems, do NOT cover or wrap pump with plastic film or bags.

### 8.1. Storing Pump For Winterization



**WARNING** – To avoid dangerous or fatal electrical shock hazard, turn OFF power to motor before draining pump. Failure to disconnect power may result in serious personal injury or death.

1. Drain water level below all inlets to the pool.
2. Remove drain plugs and strainer cover from strainer housing. (See “Parts Diagram” in section 10.1 of this manual for pump component locations.)
3. Disconnect pump from mounting pad, wiring (after power has been turned OFF), and piping.
4. Once the pump is fully drained of water, re-install the strainer cover and drain plugs. Store pump in a dry area.

## 9. Shaft Seal Change Instructions

### IMPORTANT SAFETY INSTRUCTIONS PLEASE READ AND FOLLOW ALL INSTRUCTIONS

When servicing electrical equipment, basic safety precautions should always be observed including the following. Failure to follow instructions may result in injury.

- **WARNING** – To reduce risk of injury, do not permit children to use this product.
- Disconnect all electrical power service to pump before beginning shaft seal replacement.
- Only qualified personnel should attempt rotary seal replacement. Contact your local authorized Hayward Dealer or service center if you have any questions.
- Refer to **Figure 10.1-1** for pump component locations.

Exercise extreme care in handling both the rotating and the stationary sections of the two-part replacement seal. Foreign matter or improper handling will easily scratch the graphite and ceramic sealing surfaces.

### 9.1. Removing the Motor Assembly

1. Remove the six (6) 5/16" x 2" hex head bolts (item #17), which hold the motor assembly to the pump/strainer housing (item #3), using a 1/2" wrench or socket.
2. Slide the motor assembly out of the pump/strainer housing (item #3), exposing the diffuser (item #9). Remove the two diffuser screws (item #7), and pull the diffuser (item #9) off of the seal plate (item #15) to expose the impeller (item #12).

USE ONLY HAYWARD GENUINE REPLACEMENT PARTS

### 9.2. Removing the Impeller

3. To prevent the motor shaft from turning, secure using a 5/16" hex wrench in the socket on the motor shaft.
4. Rotate the impeller screw (item #10) clockwise (note that screw has left-hand thread) and remove. Remove the impeller (item #12) by rotating counterclockwise.

### 9.3. Removing the Ceramic Seat

5. Remove the spring seal assembly (item #13) and seal plate (item #15) from the motor by removing the four (4) 3/8" x 1" bolts (item #18) that secure it to the motor, using a 9/16" wrench or socket. Remove the motor support bracket (item #20) from the seal plate (item #15).
6. Press the ceramic seat with rubber cup out of the seal plate (item #15). Use a small screwdriver to tap seal out.  
**STOP** - Clean all recesses & parts to be reassembled. Inspect gaskets & replace if necessary.

### 9.4. Seal Installation

7. Clean and lightly lubricate the motor shaft and seal recesses in the seal plate (item #15) with a dilute solution of non-granulated liquid-type soap. Gently wipe the polished face of the ceramic seal with a soft cotton cloth. Lubricate the rubber cup on the ceramic seat and press it firmly into the recess of the seal plate (item #15), with the polished ceramic surface facing out.
8. Reassemble the motor to the seal plate (item #15) using the four (4) 3/8" x 1" bolts (item #18), and re-attach the motor support (item #20) to the seal plate (item #15). **Ensure that the upper two housing bolts are installed in the seal plate prior to mounting the motor to the seal plate.**
9. Gently wipe the black, polished surface of the spring seal assembly (item #13) with a soft cotton cloth.
10. Press the spring seal assembly (item #13) onto the motor shaft, with the black polished surface facing the ceramic seat.

### 9.5. Replacing the Impeller and Diffuser

11. Screw the impeller (item #12) onto the motor shaft in a clockwise direction, and screw the impeller screw (item #10) into the motor shaft in a counterclockwise direction. Tighten snugly by holding motor shaft with wrench as noted in step #4. Place the impeller ring (item #11) back onto the impeller (item #12), with flange facing towards the diffuser (item #9).
12. Place the diffuser (item #9) over the impeller (item #12) and onto the seal plate (item #15), aligning the three pins on the diffuser (item #9) with the three holes on the seal plate (item #15). Replace the two diffuser screws (item #7).

### 9.6. Replacing the Motor Assembly

13. Slide the motor assembly, with the diffuser (item #9) in place, into pump/strainer housing (item #3), being careful not to disturb the diffuser gasket (item 8)
14. Fasten assembly to pump/strainer housing (item #3) using the six (6) 5/16" x 2" bolts (item #17). (Be sure housing gasket (item #14) is in place, and lubricated. Replace if damaged). Tighten bolts alternately and evenly to 185 inch-pounds according to housing bolt torque pattern detail.

# 10. Replacement Parts

## 10.1. Parts Diagram

Figure 10.1-1

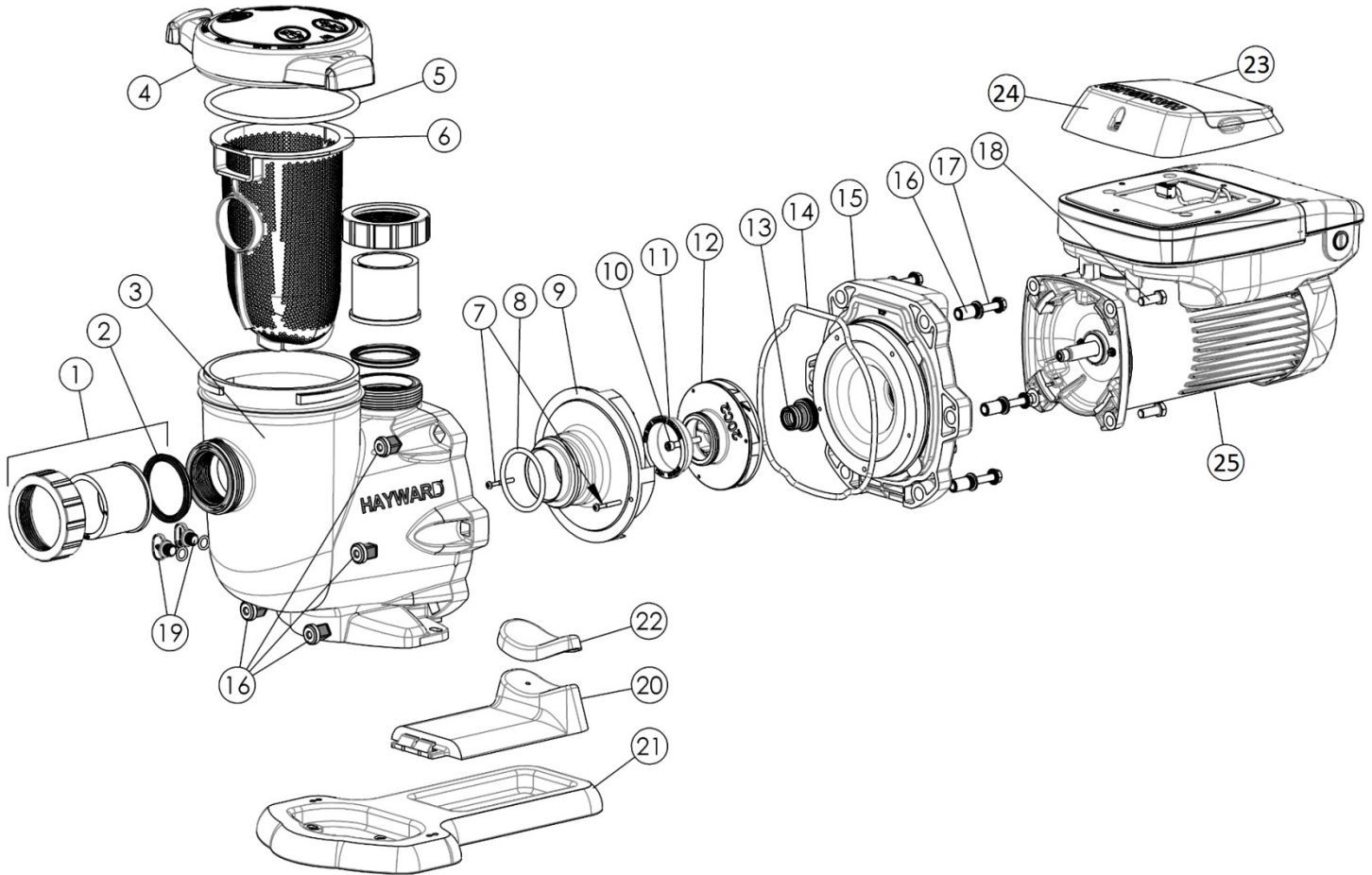

## 10.2. Parts Listing

Ref. No.	Part No.	Description	Qty.
1	SPX3200UNKIT	Union Connector Kit (Includes 2 Nuts, Connectors & Gaskets)	1
2	SPX3200UG	Union Gasket	1
3	SPX3200A	Pump Strainer Housing, 2" x 2 1/2" with Drain Plugs	1
4A	SPX3200DLS	Strainer Cover Kit (Includes Strainer Cover, Lock Ring & O-Ring)	1
4B	SPX3200DLSB	Strainer Cover Kit for Biguanide Sanitizers (Includes Strainer Cover, Lock Ring & O-Ring); NOT Pressure Testable	1
5	SPX3200S	Strainer Cover O-Ring	1
6	SPX3200M	Strainer Basket	1
7	SPX3200Z8	Diffuser Screw	1
8	SPX4000Z1	Diffuser O-Ring	1
9	SPX3200B3	Diffuser	1
10	SPX3200Z1	Impeller Screw	1

**USE ONLY HAYWARD GENUINE REPLACEMENT PARTS**

Ref. No.	Part No.	Description	Qty.
11	SPX3021R	Impeller Ring	1
12	SPX3220C	Impeller with Impeller Screw	1
13A	SPX3200SA	Shaft Seal Assembly	1
13B	SPX4000SAV	Shaft Seal Assembly (Viton)	1
14	SPX3200T	Housing O-Ring	1
15	SPX3200E	Seal Plate	1
16	SPX3200Z211	Housing Insert/Seal Plate Spacer Kit	1
17	SPX3200Z3	Housing Bolt	1
18	SPX3200Z5	Motor Bolt	1
19	SPX4000FG	Drain Plug with O-Ring	1
20	SPX3200GA	Motor Support	1
21	SPX3200WF	Optional Riser Base aligns with Pentair® WhisperFlo® pump*)	1
22	SPX3200Q	Motor Support Adapter	1
23	SPX3400DR4	Motor Drive Display Cover (Cover only)	1
24	SPX3200LCD	Digital Control Interface Assembly	1
25A	SPX3206Z1VSPE	Power End Assembly, Non-SVRS (Includes #7-15, 2 ea. #16-17, #18, #24 & Motor Assembly)	1
25B	SPX3206Z1VSPEVR	Power End Assembly, SVRS (Includes #7-15, 2 ea. #16-17, #18, #24 & Motor Assembly)	1
-	SPX3400DRKIT	Wall Mount Kit	1
-	SPX3200DRCC	Comm Cable Kit	1

\* WhisperFlo is a registered trademark of Pentair Aquatic Systems, which is used herein for identification purposes only. This is a retrofit base for existing WhisperFlo pump installations. Pentair Aquatic Systems is not affiliated with Hayward Pool Products.

USE ONLY HAYWARD GENUINE REPLACEMENT PARTS

# 11. Troubleshooting

## 11.1. General Problems

- **Motor Will NOT Start:**
  1. Make sure the terminal board connections agree with the wiring diagram on the pump data plate label.
  2. Be sure the pump is wired for the available field supply voltage.
  3. Check for and correct any improper or loose wiring connections; open switches or relays; tripped circuit breakers, or blown fuses.
  4. Manually check the rotation of the motor shaft for free movement and lack of obstruction. Correct if necessary.
- **Motor Shuts OFF:**
  1. Check for low voltage or power drop at the motor (frequently caused by undersized wiring). Contact a qualified professional to verify the electrical connections.
- **Motor Hums, But Does NOT Start:**
  1. Impeller jammed with debris. Have a qualified repair professional open the pump and remove the debris.
- **Pump Won't Prime:**
  1. Empty pump/strainer housing. Make sure the pump/strainer housing is filled with water and the cover o-ring is clean. Ensure the o-ring is properly seated in the cover o-ring groove. Ensure the o-ring sealing surface is lubricated with "Jack's 327" and that the strainer cover is locked firmly in position. Lubricant will help to create a tighter seal.
  2. Loose connections on the suction side. Tighten the pipe/union connections.  
**Note:** Any self-priming pump will not prime if there are suction air leaks. Leaks will result in bubbles emanating from the return fittings on the pool wall.
  3. Leaking O-ring or packing glands on valves. Tighten, repair, or replace the valves.
  4. Strainer basket or skimmer basket loaded with debris. Remove the strainer housing cover or the skimmer cover. Clean the basket, and refill the strainer housing with water. Tighten the cover.
  5. Suction side clogged. Contact a qualified repair professional. You should have 5" - 6" of vacuum at the strainer cover (your pool dealer can confirm this with a vacuum gauge). You may be able to check by removing the skimmer basket and holding an object over the bottom port with the skimmer full and the pump running. If no suction is felt, check for line blockage.
    - a. If the pump develops a vacuum, check for a blocked suction line or a dirty strainer basket. An air leak in the suction piping may be the cause.
    - b. If the pump does not develop a vacuum and the pump has sufficient "priming water":
      - i. Re-check the strainer housing cover and all threaded connections for suction leaks. Check if all system hose clamps are tight.
      - ii. Check voltage to ensure that the motor is rotating at full rpm's.
      - iii. Open the housing cover and check for clogging or obstruction in suction. Check the impeller for debris.
      - iv. Remove and replace the shaft seal only if it is leaking.
- **Low Flow – Generally:**
  1. Clogged or restricted strainer or suction line. Contact a qualified repair professional.
  2. Undersized pool piping. Correct the piping size.
  3. Plugged or restricted discharge line of filter, valve partially closed (high gauge reading). Sand filters – backwash as per manufacturer's instructions; D.E. filters – backwash as per manufacturer's instructions; Cartridge filters – clean or replace the cartridge.
  4. Air leak in suction (bubbles issuing from return fittings). Re-tighten the suction and discharge connections using PTFE tape. Inspect other plumbing connections, and tighten as required.
  5. Plugged, restricted, or damaged impeller. Replace the impeller including a new seal assembly.

USE ONLY HAYWARD GENUINE REPLACEMENT PARTS



- **Noisy Pump:**
  1. Air leak in suction piping, cavitations caused by restricted or undersized suction line or leak at any joint, low water level in pool, and unrestricted discharge return lines. Correct the suction condition or throttle return lines, if practical. Holding your hand over the return fitting will sometimes prove this, or by putting in a smaller eyeball fitting.
  2. Vibration due to improper mounting, etc. Mount the pump on a level surface and secure the pump to the equipment pad.
  3. Foreign matter in the pump housing. Loose stones/debris hitting the impeller could be the cause. Clean the pump housing.
  4. Motor bearings noisy from normal wear, rust, overheating, or concentration of chemicals causing seal damage, which will allow chlorinated water to seep into bearings wiping out the grease causing bearing to whine. All seal leaks should be replaced at once.
  
- **Interference With Home Automation/Power Line Communication Equipment:**
  1. Make sure the terminal board connections agree with the wiring diagram on the pump data plate label.
  2. Check for and correct any improper or loose wiring connections.
  3. Install noise filter (from home automation/power line communication equipment vendor) to prevent equipment interference.

### 11.2. Check System Messages

Code	Troubleshooting
<b>Check System DC voltage too high</b>	Indicates that the internal DC bus voltage is too high. Verify that line voltage is within 10% of pump rated voltage at the terminal block.
<b>Check System DC voltage too low</b>	Indicates that the internal DC bus voltage is too low. Verify that line voltage is within 10% of pump rated voltage at the terminal block. Also, verify that power supply connections are properly made at the circuit breaker as well as at the terminal block.
<b>Check System Drive is overheated</b>	Indicates that the internal components of the drive have become overheated. Motor airflow path should be checked for obstructions and cleared if present. Check ambient temperature and verify against motor nameplate (50°C/122°F).
<b>Check System Drive overload</b>	Indicates that motor current is too high. Check impeller, diffuser, shaft seal, and motor for any issues or binding.
<b>Check System Pump has stalled</b>	Indicates that the drive has lost control over motor shaft rotation. Check impeller, diffuser, shaft seal, and motor for any issues or binding.
<b>Check System Pump failed to start</b>	Indicates that the drive was not able to start the motor. Check impeller, diffuser, shaft seal, and motor for any issues or binding.
<b>Check System Motor phase lost</b>	Indicates that one of the motor phases is open and that the motor/drive may need to be replaced. Contact Hayward Technical Service for additional assistance.
<b>Check System Processor failed</b>	Indicates that there is a problem with the processor in the motor/drive, and that the motor/drive may need to be replaced. Contact Hayward Technical Service for additional assistance.
<b>Check System Communication failed</b>	Indicates that there are communication problems between the user interface and motor/drive. Connections between the user interface and motor/drive should be verified.
<b>Check System Memory failed</b>	Indicates that the drive memory has been damaged or corrupted, and that the motor/drive may need to be replaced. Contact Hayward Technical Service for additional assistance.

USE ONLY HAYWARD GENUINE REPLACEMENT PARTS

Code	Troubleshooting
<b>Check System Drive comm failed</b>	Indicates that there are communication problems inside the motor/drive, and that the motor/drive may need to be replaced. Contact Hayward Technical Service for additional assistance.
<b>Check System Error code XX</b>	Indicates that the user interface is receiving an error from the motor/drive that it does not understand. Contact Hayward Technical Service for additional assistance.

**Note:** All errors can be manually reset by pressing Stop/Resume when the error message is shown, or by cycling power applied to the pump after the error has occurred. Under certain circumstances, the “Drive overload” error can only be reset by cycling power applied to the pump. If the troubleshooting steps listed above do not help to resolve the error condition, then the problem may be internal to the motor/drive. Contact Hayward Technical Service at (908) 355-7995 for additional assistance.

## 12. Warranty

### HAYWARD LIMITED WARRANTY

To buyer, as original purchaser of this equipment, Hayward Pool Products, 620 Division Street, Elizabeth, New Jersey, warrants its products to be free from defects in materials and workmanship for a period of (see below) from the date of purchase.

Parts which fail or become defective during the warranty period, except as a result of freezing, negligence, improper installation, use, or care, shall be repaired or replaced, at our option, without charge, within 90 days of the receipt of defective product, barring unforeseen delays.

To obtain warranty replacements or repair, defective components or parts should be returned, transportation paid, to the place of purchase, or to the nearest authorized Hayward service center. For further Hayward dealer or service center information, contact Hayward customer service department. No returns may be made directly to the factory without the express written authorization of Hayward pool Products.

To original purchasers of this equipment, Hayward Pool Products warrants its products to be free from defects in materials and workmanship for a period of (see below) from the date of purchase.

Filters which become defective during the warranty period, except as a result of freezing, negligence, improper installation, use or care, shall be repaired or replaced, at our option, without charge,

All other conditions and terms of the standard warranty apply.

Hayward shall not be responsible for cartage, removal and/or reinstallation labor or any other such costs incurred in obtaining warranty replacements.

The Hayward Pool Products warranty does not apply to components manufactured by others. For such products, the warranty established by the respective manufacturer will apply.

Some states do not allow a limitation on how long an implied warranty lasts, or the exclusion or limitation of incidental or consequential damages, so the above limitation or exclusion may not apply to you.

This warranty gives you specific legal rights, and you may also have other rights, which vary from state to state.

Product Line	Warranty Period
Standard Line	One (1) year
Expert line	Four (4) years

**\*Supersedes all previous publications.**

**Hayward pool Products  
620 Division Street  
Elizabeth, NJ 07207**

USE ONLY HAYWARD GENUINE REPLACEMENT PARTS

## 13. Product Registration

DATE OF INSTALLATION	_____
INITIAL PRESSURE GAUGE READING (CLEAN FILTER)	_____
PUMP MODEL	_____

**\*Retain this Warranty Certificate in a safe and convenient location for your records**



# FCC Compliance Statement:

This device complies with part 15 of the FCC rules. Operation is subjected to the following two conditions: (1) This device may not cause harmful interference, and (2) this device must accept any interference received, including interference that may cause undesired operation.

This equipment has been tested and found to comply with limits for a Class B digital device, pursuant to Part 15 of the FCC rules. These limits are designed to provide reasonable protection against harmful interference in residential installations. This equipment generates, uses, and can radiate radio frequency energy, and if not installed and used in accordance with the instructions, may cause harmful interference to radio communications.

However, there is no guarantee that interference will not occur in a particular installation. If this equipment does cause interference to radio or television equipment reception, which can be determined by turning the equipment off and on, the user is encouraged to try to correct the interference by one of more of the following measures:

- Reorient or relocate the receiving antenna.
- Move the equipment away from the receiver.
- Plug the equipment into an outlet on a circuit different from that to which the receiver is connected.
- Consult the dealer or an experienced radio/television technician for additional suggestions.



**DETACH HERE: Fill out bottom portion completely and mail within 10 days of purchase/installation or register online.**

## 2.70 THP VS Pump Family

## Warranty Card Registration

Please Print Clearly:

First Name \_\_\_\_\_ Last Name \_\_\_\_\_

Street Address \_\_\_\_\_

City \_\_\_\_\_ State \_\_\_\_\_ Zip \_\_\_\_\_

Phone Number \_\_\_\_\_ Purchase Date \_\_\_\_\_

E-Mail Address \_\_\_\_\_

Serial Number																				
---------------	--	--	--	--	--	--	--	--	--	--	--	--	--	--	--	--	--	--	--	--

(10-17 digit number)

Model Number \_\_\_\_\_

Pool Capacity \_\_\_\_\_ (U.S. Gallons)

Please include me on all e-mail communications regarding Hayward Equipment or promotions.

**Mail to: Hayward Pool Products, 620 Division Street, Elizabeth, NJ 07207**

**Attn: Warranty Dept**

**Or REGISTER YOUR WARRANTY ON-LINE AT [WWW.HAYWARD.COM](http://WWW.HAYWARD.COM)**

Years Pool has been in service  
 < 1 year    1-3    4-5    6-10    11-15    >15

Purchased from \_\_\_\_\_

Builder    Retailer    Pool Service    Internet/Catalog

Company Name \_\_\_\_\_

Address \_\_\_\_\_

City \_\_\_\_\_ State \_\_\_\_\_ Zip \_\_\_\_\_

Phone \_\_\_\_\_

Type of Pool:

Concrete/Gunite    Vinyl    Fiberglass

Other \_\_\_\_\_

New Installation    Replacement

Installation for:

In Ground    Spa