

Pool FROG®

XL PRO™ In GROUND

MINERAL SYSTEM FOR POOLS

Patented Mineral Pool Disinfectant



THE POOL FROG®
MINERAL RESERVOIR
MUST BE REPLACED
EVERY SIX MONTHS
OR AFTER ONE POOL
SEASON WHICHEVER
IS SHORTER.

Model 5450

Instruction Manual

Customer Service 800-222-0169

TABLE OF CONTENTS

POOL FROG® Introduction	3
Swimming Pool Tips	4
Start-up and Operation	5-6
Replacing POOL FROG® Mineral Reservoir	7
Replacing FROG BAM®	8
Replacing POOL FROG® Pac	9
Troubleshooting	10
Parts List	11
Replacing Control Dial O-Rings	12
Replacing Cap O-Ring and Knob	12
Winterizing	13
In-line Installation	14
For Proper Performance	15
Warranty	16

For information on King Technology's entire product line, visit our website at www.kingtechnology.com

POOL FROG®

Welcome to easier pool care courtesy of POOL FROG® XL PRO. With POOL FROG® XL PRO, your pool water will look and feel better without a lot of work or a lot of chlorine. This system controls bacteria using a combination of minerals and reduced chlorine levels-up to 50%* less. There are 5 parts to the POOL FROG® XL PRO System: Two In Ground Cyclers, the POOL FROG® Mineral Reservoir, FROG BAM® 90-day Algae Preventative and the POOL FROG® Pac.

Part 1 & 2 POOL FROG® XL PRO Cyclers

The water treatment centers that control the flow of water through the POOL FROG® Mineral Reservoir in one and the POOL FROG® Pac in the other.



POOL FROG® Mineral Cycler

For In Ground Pools up to 40,000 gallons.

POOL FROG® Chlorine Cycler

Part 3 POOL FROG® Mineral Reservoir

Holds the minerals and fits inside the POOL FROG® Mineral Cycler.



THE POOL FROG® MINERAL RESERVOIR MUST BE REPLACED EVERY SIX MONTHS OR AFTER ONE POOL SEASON WHICHEVER IS SHORTER.

Part 4 FROG BAM®

Use with the POOL FROG® XL PRO System for an Algae-Protection Guarantee.



Part 5 POOL FROG® Pac

Pre-filled with chlorine tablets and fits inside the POOL FROG® Chlorine Cycler.



(POOL FROG® Mineral Reservoir sold inside POOL FROG® Mineral Cycler and separately for replacements. POOL FROG® Pac and FROG BAM® sold separately.)

*Compared to the minimum EPA recommended chlorine level of 1.0 ppm for a stabilized swimming pool.

Swimming Pool Tips

Start-up and Yearly Maintenance

1.

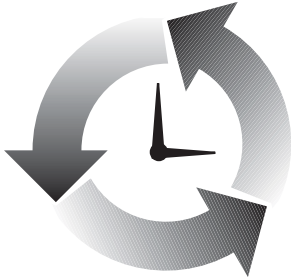

• Make sure the pool has adequate circulation. The pool water must completely circulate through the pump and filter at least 1 to 2 times per day. This usually requires 8 to 12 hours. Check with your dealer for the proper circulation time for your pool.

2.

• Before beginning with any pool care program, you must first balance your pool water. Take a water sample to your local pool professional or use a complete test kit that will test for the following important elements.

Water Balance Guidelines

pH:	7.2 – 7.8
Total Alkalinity:	60 – 120 ppm
Calcium Hardness:	150 – 400
Total Dissolved Solids:	<1500
Stabilizer:	20 – 80 ppm
Free Chlorine:	0.5 – 1.0 ppm

3.

Cu
Mg Fe

• If your fill water is high in metals, use a sequestering agent or metal out product at start-up only before using the POOL FROG® Mineral Reservoir. See your local dealer for details on using these products and always follow manufacturers directions carefully.

4.



• After your pool is up and running smoothly, continue to test your water for pH, total alkalinity and chlorine and maintain its balance by adding any necessary adjustment products (see your dealer for details).

5.

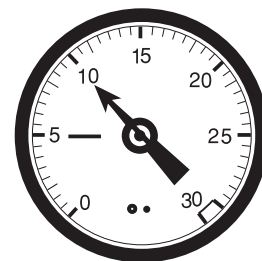

• Check the pool's filter gauge often and periodically clean filter per the manufacturer's directions. A dirty filter will slow the flow of water which could hamper proper circulation.

Start-up and Operation



1.

- Add a stabilizer or conditioner to the pool at the beginning of the season if the stabilizer level is below 20 ppm. This will prevent chlorine burn off. Follow manufacturer's directions carefully.



2.

- Shock the pool with chlorine to rid the water of all contaminants before beginning with POOL FROG® XL PRO. Follow manufacturer's directions carefully.
- **THIS STEP IS VERY IMPORTANT TO START-UP. USE CHLORINE SHOCK ONLY.**

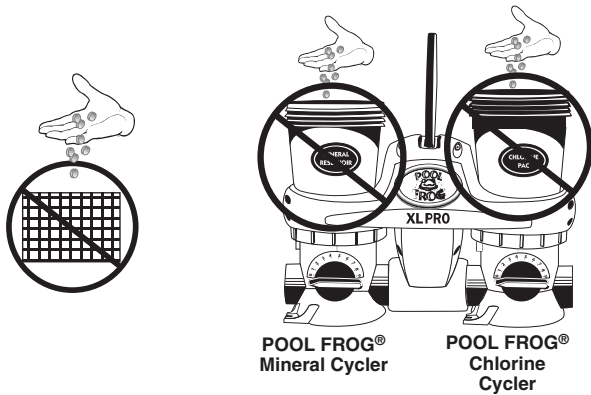

- **Do not** add shock in or near the skimmer or into the POOL FROG® XL PRO Cyclers as it could damage equipment, risk potential explosion or discolor your pool surface.

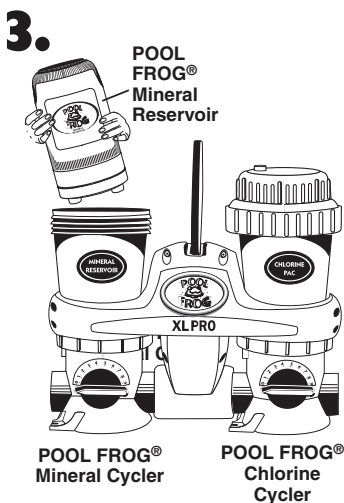

3.

- Install a POOL FROG® Mineral Reservoir into the POOL FROG® Mineral Cyclers. (Follow directions on page 7.)

REPLACE THE POOL FROG® MINERAL RESERVOIR EVERY 6 MONTHS OR AFTER ONE POOL SEASON WHICHEVER IS SHORTER.

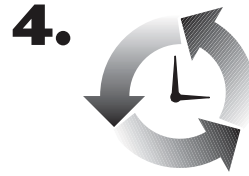

4.

- Replace cap and set dial on POOL FROG® Mineral Cyclers to Maximum.

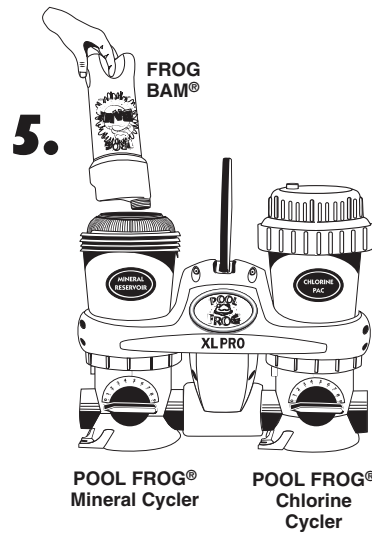

5.

- For an Algae Protection Guarantee insert FROG BAM® into POOL FROG® Mineral Reservoir in POOL FROG® Mineral Cyclers. (Follow directions on page 8.)

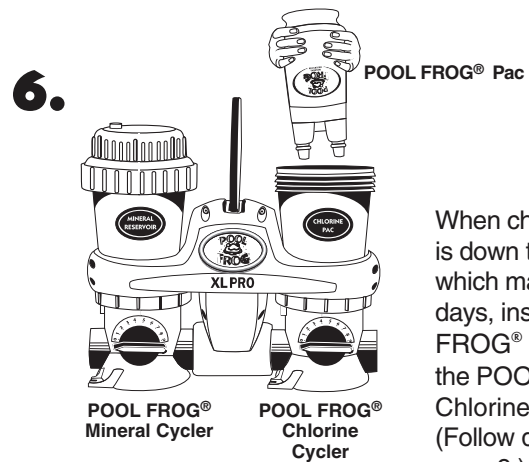

6.

- When chlorine reading is down to 1.0 ppm which may take a few days, insert a POOL FROG® Pac into the POOL FROG® Chlorine Cyclers. (Follow directions on page 9.)

Start-up and Operation

This system is designed to work effectively with a variety of pool equipment as long as the following basic procedures are followed.

7. • Once you've set the dial on the POOL FROG® Mineral Cycler to Maximum, set control dial on POOL FROG® Chlorine Cycler by matching up the parameters of your pool on the chart below. THIS IS A STARTING POINT ONLY and may need to be adjusted to fit your individual pool needs. See #8 below for adjusting directions. **IMPORTANT:** Pump run times of at least 6 hours per day at high speed are recommended for proper performance. If running the pump at low speed only or on high speed less than 6 hours, please follow the 24 hour low speed directions below.



SINGLE-SPEED PUMP OR HIGH-SPEED PUMP RUN TIME												
In Ground POOL SIZE Gallons	6 Hour Pump Run Time				12 Hour Pump Run Time				24 Hour Pump Run Time			
	PUMP SIZE				PUMP SIZE				PUMP SIZE			
	3/4 hp	1 hp	1 1/2 hp	2 hp	3/4 hp	1 hp	1 1/2 hp	2 hp	3/4 hp	1 hp	1 1/2 hp	2 hp
7,000	3.5	3.0	2.5	* 2.5	2.5	2.0	* 3.5	* 3.0	1.0	* 3.0	* 2.5	* 2.0
9,000	4.0	3.5	3.0	2.5	3.0	2.5	2.0	* 3.5	2.0	* 3.5	* 2.5	* 2.5
12,000	4.5	4.0	3.5	3.0	3.5	3.0	2.5	2.0	2.5	2.0	1.0	* 3.0
18,000	NR	4.5	4.0	3.5	4.5	3.5	3.0	2.5	3.0	2.5	2.0	1.5
25,000	NR	NR	4.5	3.5	NR	4.5	3.5	3.0	3.5	3.0	2.5	2.0
30,000	NR	NR	5.5	4.5	NR	5.0	4.5	3.5	4.0	3.5	3.0	2.5
35,000	NR	NR	6.5	5.5	NR	6.0	5.0	4.5	5.0	4.0	3.5	3.0
40,000	NR	NR	NR	6.5	NR	NR	6.0	5.0	6.0	5.0	4.0	3.5

* Bypass installation recommended. NR – This pump size is not recommended for this size pool.

24 HOUR, LOW SPEED PUMP RUN TIME

In order to ensure proper performance when running the pump on low speed for 24 hours per day or high speed less than 6 hours per day, bleed the air while the pump is on by unscrewing BOTH cycler cap knobs until water appears. Then screw the knobs back on. Repeat this process each time the caps are removed for any reason. Set the control dial on the chlorine cycler to 6 and follow the adjustment directions in Step 8 to determine the correct setting for your pool.

In Ground POOL SIZE Gallons	6 Hour Pump Run Time			
	3/4 hp	1 hp	1 1/2 hp	2 hp
7,000	3.5	3.0	2.5	* 2.5
9,000	4.0	3.5	3.0	2.5
12,000	4.5	4.0	3.5	3.0
18,000	NR	4.5	4.0	3.5
25,000	NR	NR	4.5	3.5
30,000	NR	NR	5.5	4.5
35,000	NR	NR	6.5	5.5
40,000	NR	NR	NR	6.5

Find your starting dial setting by matching up the parameters of your pool on the above chart. An In ground pool with approximately 18,000 gallons with a 1 horse power pump running 6 hours a day at high speed would require a starting dial setting of 4.5. Example above.

8. • For the first week test the pool water daily for free chlorine to ensure correct dial setting. Continue to test weekly throughout the season.



• After each testing, adjust the dial up by 1/2 increment if the free chlorine reading has dropped below 0.5 ppm or adjust down by 1/2 increment if the reading has risen above 1.0 ppm.

Continue this process each day until the free chlorine reading stabilizes to at least 0.5 ppm.

• Remember to adjust dial by 1/2 increments only in order to prevent over chlorination which may bleach pool surfaces.



• Shock pool every two weeks or as needed to maintain water quality. Follow label directions on the shock treatment used.

• Do not add shock in or near the skimmer or into either of the POOL FROG® Cyclers as it could damage equipment, risk potential explosion or discolor your pool surface.

If using another means of chlorine support
Follow steps 1-5 on page 5 then continue below.

6.



• Leave POOL FROG® Chlorine Cycler empty and set dial on POOL FROG® Mineral Cycler to Maximum.

7.



• Shock pool every two weeks or as needed to maintain water quality. Follow label directions on the shock treatment used.

• Do not add shock in or near the skimmer or into either of the POOL FROG® Cyclers as it could damage equipment, risk potential explosion or discolor your pool surface.

Replacing a POOL FROG® Mineral Reservoir

(POOL FROG® Mineral Reservoirs MUST be Replaced Every Season)

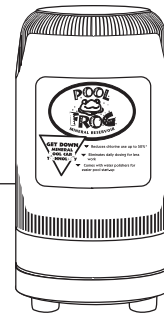

1.

INGROUND SERIES 5400 (Order #01-19-5462)
NOW FITS THE FOLLOWING CYCLERS:
 POOL FROG Series 5400, 5450 or 5600
 Prevail Series 5790



- Check the top of the box and back label of product to make sure you have the correct POOL FROG® Mineral Reservoir to fit your POOL FROG® Mineral Cyclers.

THE POOL FROG® MINERAL RESERVOIR MUST BE REPLACED EVERY 6 MONTHS OR AFTER ONE POOL SEASON WHICHEVER IS SHORTER

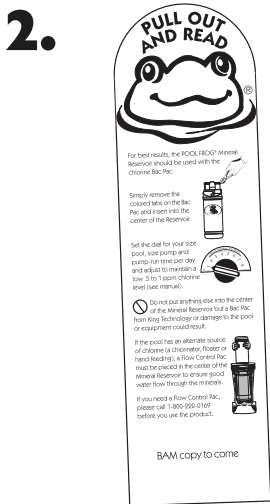

Open the box and remove the POOL FROG® Mineral Reservoir.

- IMPORTANT:** Remove and read the information card.

Please note: Complete instructions for inserting a POOL FROG® Mineral Reservoir, FROG BAM® and POOL FROG® Pac are included inside the POOL FROG® Mineral Reservoir box.

3.

CAUTION Read Carefully

- USE ONLY the factory recommended replacement POOL FROG® Mineral Reservoir, FROG BAM® and POOL FROG® Pac. DO NOT USE any other pac or bulk chemical tablets in the POOL FROG® Cyclers. Use of any other product could result in damage to pool equipment or surface, unsafe pool conditions, fire or explosion. Warranty will be void if the correct POOL FROG® Mineral Reservoir, FROG BAM® and POOL FROG® Pac are not used.

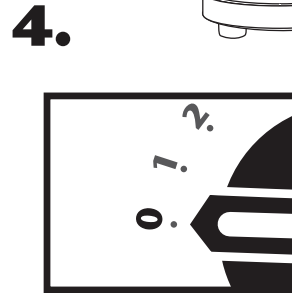

- Turn off pump. Turn dial to Setting 0. This reduces the flow of water into the unit when the cap is open.



- Use the cap tool included with POOL FROG® XL PRO to loosen cap on POOL FROG® Mineral Cyclers by hitting the handle with the flat of your hand counter clockwise.

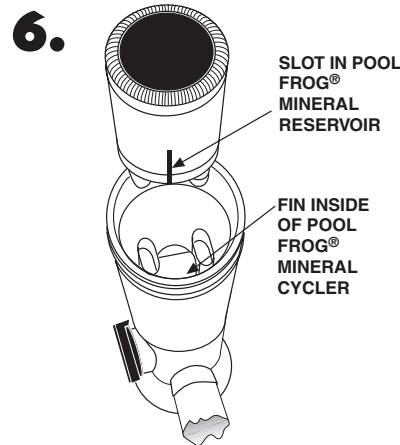

- Find slot on side of POOL FROG® Mineral Reservoir and line up with fin inside the POOL FROG® Mineral Cyclers. Lower POOL FROG® Mineral Reservoir into POOL FROG® Mineral Cyclers until secure.

Using FROG BAM® for an Algae Protection Guarantee

If you are not using FROG BAM®, proceed to Step 15.
See FROG BAM® product labeling for complete directions for use (EPA Reg. No. 53735-9).

For a preventive dose add:

- One FROG BAM® for pools up to 15,000 gallons.
- Two FROG BAM® for pools between 15,000 and 30,000 gallons.

***NOTE:** Do NOT super chlorinate 48 hours before or after using this product. Avoid using other chemicals until this product has been circulated (filtered) for at least 24 hours.



- Remove cap from FROG BAM® without removing seal.

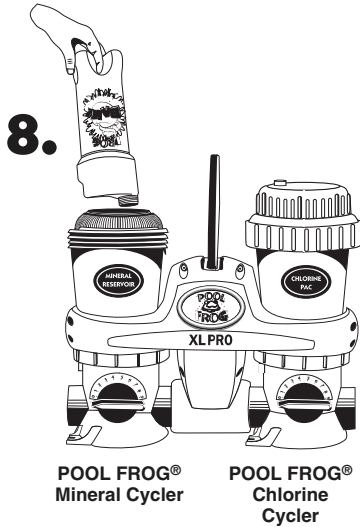

- Insert upside down into center of POOL FROG® Mineral Reservoir pushing down firmly on key to puncture seal.



- Replace cap by hand only. **DO NOT OVER TIGHTEN.**

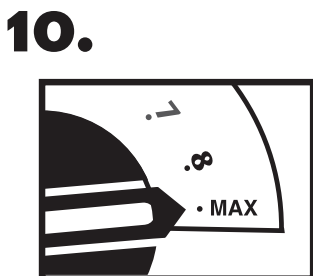

- Turn control dial on POOL FROG® Mineral Cycler to Maximum.

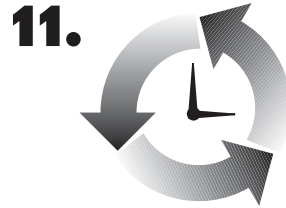

- Turn pump on for 90 minutes allowing FROG BAM® to circulate through pool.



- To remove FROG BAM®, turn pump off. Turn dial to Setting 0.



- Remove POOL FROG® Mineral Cycler cap.

- Lift FROG BAM® up and allow any water in the container to drain through the POOL FROG® Mineral Cycler before discarding in trash.

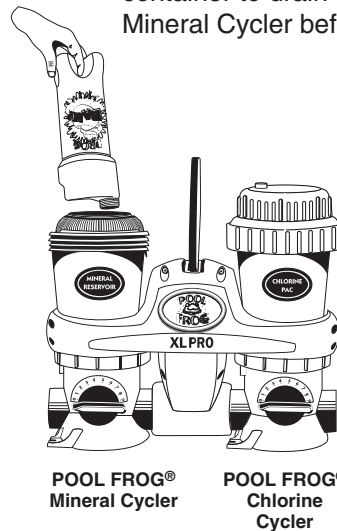

NOTE: If water shows more than a hint of blue inside POOL FROG® Mineral Cycler, replace the cap, turn dial to Maximum and run the pump for one minute.

14a. If pool size requires additional FROG BAM®, repeat steps 7-14.

14b. When water is clear in POOL FROG® Mineral Cycler, proceed to step 15.

Using the POOL FROG® Pac

CAUTION Read Carefully – USE ONLY the factory recommended replacement POOL FROG® Pac. (See label.) DO NOT USE any other pac or bulk chemical tablets in the POOL FROG® Cycler. Use of any other product could result in over chlorination, bleached liners, unsafe pool conditions, fire or explosion. Warranty will be void if the correct pac is not used.

15.



POOL FROG® Pac recommended to assure up to 50% reduction in chlorine use*. POOL FROG® Pac sold separately. (EPA Reg. No. 53735-2)

**Compared to the minimum EPA recommended chlorine level of 1.0 ppm for a stabilized swimming pool.*

16.



Avoid sparks, open flame or smoking when handling the POOL FROG® Pac.

17.

Cut handle from POOL FROG® Pac using 2" PVC cutting tool or a hacksaw (**KEEP OUT OF REACH OF CHILDREN**).

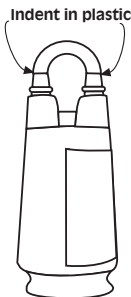

A. Find the indent in the plastic.

Cutting tool available at local hardware store.

B. If using a 2" PVC cutting tool, place curved section of tool around the narrow end of one pac tower and line up blade on indent.

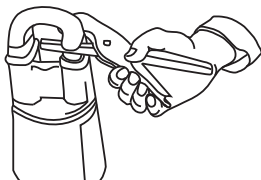

C. Squeeze the handles together. Repeat for other side.

Finished cut ends

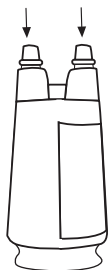

E. Whether using a 2" PVC cutting tool or a hacksaw, make sure the blade comes straight across on the indent line for a clean cut.

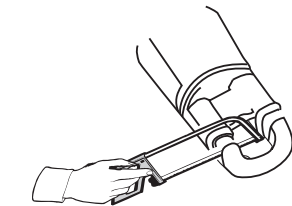

D. If using a hacksaw to cut the pac, line up hacksaw blade on indent and cut with a smooth sawing action.

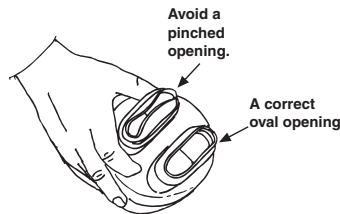

F. If openings are pinched together, open with fingers or re-cut closer to the colored screens inside POOL FROG® Pac. Leave at least 1/4" of plastic to fit into POOL FROG® Chlorine Cycler base.

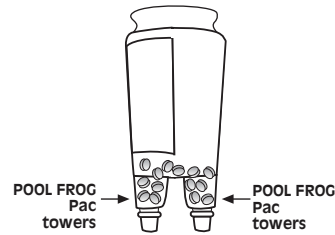

18.

Turn POOL FROG® Pac over and shake slightly until chlorine tablets fall into tower areas.

19.

Insert POOL FROG® Pac into POOL FROG® Chlorine Cycler, lining up the openings in the POOL FROG® Pac with keys in POOL FROG® Chlorine Cycler.

NOTE: Openings are a different shape than keys.

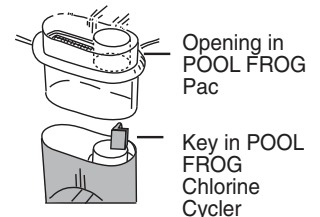
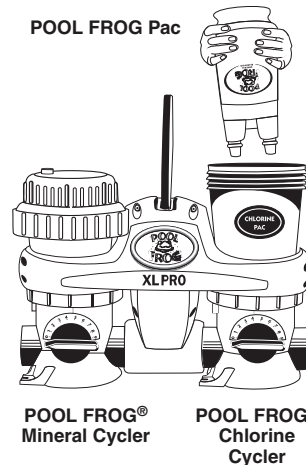

Avoid sparks, open flame or smoking while handling the POOL FROG® Pac.

20.

Replace cap by hand only. **DO NOT OVERTIGHTEN.**

DO NOT USE CAP TOOL TO TIGHTEN CAP. FOR REMOVAL ONLY.

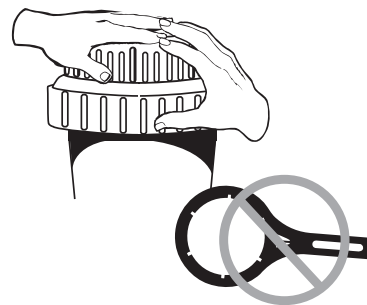

The POOL FROG® Pac is made of HDPE plastic. When the POOL FROG® Pac is empty, triple rinse in pool water, drain, and recycle or wrap in newspaper and discard in trash.

21.

Mark your calendar for the six month replacement of the POOL FROG® Mineral Reservoir, 90-day replacement of FROG BAM® and approximate replacement times for the POOL FROG® Bac Pac. Once wetted, the time-released mineral coating of the POOL FROG® Mineral Reservoir is effective up to 6 consecutive months or one pool season whichever is shorter. After that time, even if you hear the spent media inside, it is no longer effective and must be replaced.



Troubleshooting

For more in-depth troubleshooting, go to www.kingtechnology.com

Problem	Remedy		
<p>1. What do I do if the water looks cloudy?</p>	<p>1. Make sure your filtration system is working properly (i.e. clean filter, skimmer and pump basket).</p> <p>2. Make sure circulation time is adequate – increase pump time if not.</p>	<p>3. Make sure the pool is properly balanced (see page 4).</p> <p>4. Shock the water to eliminate build up of any organic matter.</p>	<p>5. Make sure pool has a free chlorine reading of 0.5 to 1.0 ppm.</p> <p>6. Check with your dealer for more information.</p>
<p>2. What do I do if the water turns color?</p>	<p>1. Metals in the fill water may have been oxidized. Have the pool tested. Shock the pool and clean the filter until water clarity returns.</p>	<p>2. Algae may be trying to form – shock the pool, increase circulation time if needed and clean the filter.</p>	<p>3. Check with your dealer for more information.</p>
<p>3. What do I do if algae forms in or on my pool?</p>	<p>1. Use a nonmetallic (polyquat) algaecide per the directions on the bottle and brush the sides of the pool often.</p> <p>2. Clean the filter and shock the pool with chlorine daily until water clarity returns.</p>	<p>3. If you are in an area of the country that struggles with algae growth, see your dealer regarding a 90-day Algae Protection Guarantee using FROG BAM®. See product hang tag for guarantee details.</p>	<p>4. Check with your dealer for more information.</p>
<p>4. What do I do if I am under chlorinating with the POOL FROG® Pac?</p>	<p>1. If you are unable to maintain 0.5 to 1.0 ppm, first make sure there are chlorine tablets in the tower areas of the POOL FROG® Pac and it is installed properly. If a correction was made, test the water in 24 hours.</p> <p>2. If still low, turn the dial up one setting and test the water again in 24 hours. Continue raising the setting by one increment each day until the proper reading is achieved.</p>	<p>3. Shock the pool if the reading has been lower than 0.5 ppm for more than one day.</p> <p>4. Make sure pump run time is at least 6 hours on high speed (40 gpm or higher) or if not, bleed the air from both cap knobs (see page 6 for directions).</p> <p>5. Contact your dealer to have your back pressure tested to ensure it is at least 4 psi.</p>	<p>6. Check for a suction side leak by looking for air bubbles in your pump basket or at the return jet. Contact dealer for help in correcting this situation.</p> <p>7. Contact King Technology's Customer Service Department at 800-222-0169.</p>
<p>5. What do I do if I am over chlorinating with the POOL FROG® Pac?</p>	<p>1. If the chlorine reading is over 3.0 ppm, remove the Chlorine Pac from the POOL FROG® Chlorine Cyclor and test the water daily until the reading is down to 1.0 ppm.</p> <p>2. Reinsert the POOL FROG® Pac, lower the dial one setting and test the water again in 24 hours. If the reading has risen,</p>	<p>lower the dial one setting again. Continue this process until proper reading is achieved.</p> <p>3. If over-chlorinating at the lowest possible setting, consider decreasing the circulation time. Depending on your pump size, you may be circulating the water more than is necessary.</p>	<p>4. Contact your dealer to have your back pressure tested. If over 8 psi consider a larger eye-ball fitting in the return jet.</p> <p>5. Contact King Technology's Customer Service Department at 800-222-0169.</p>

Parts List

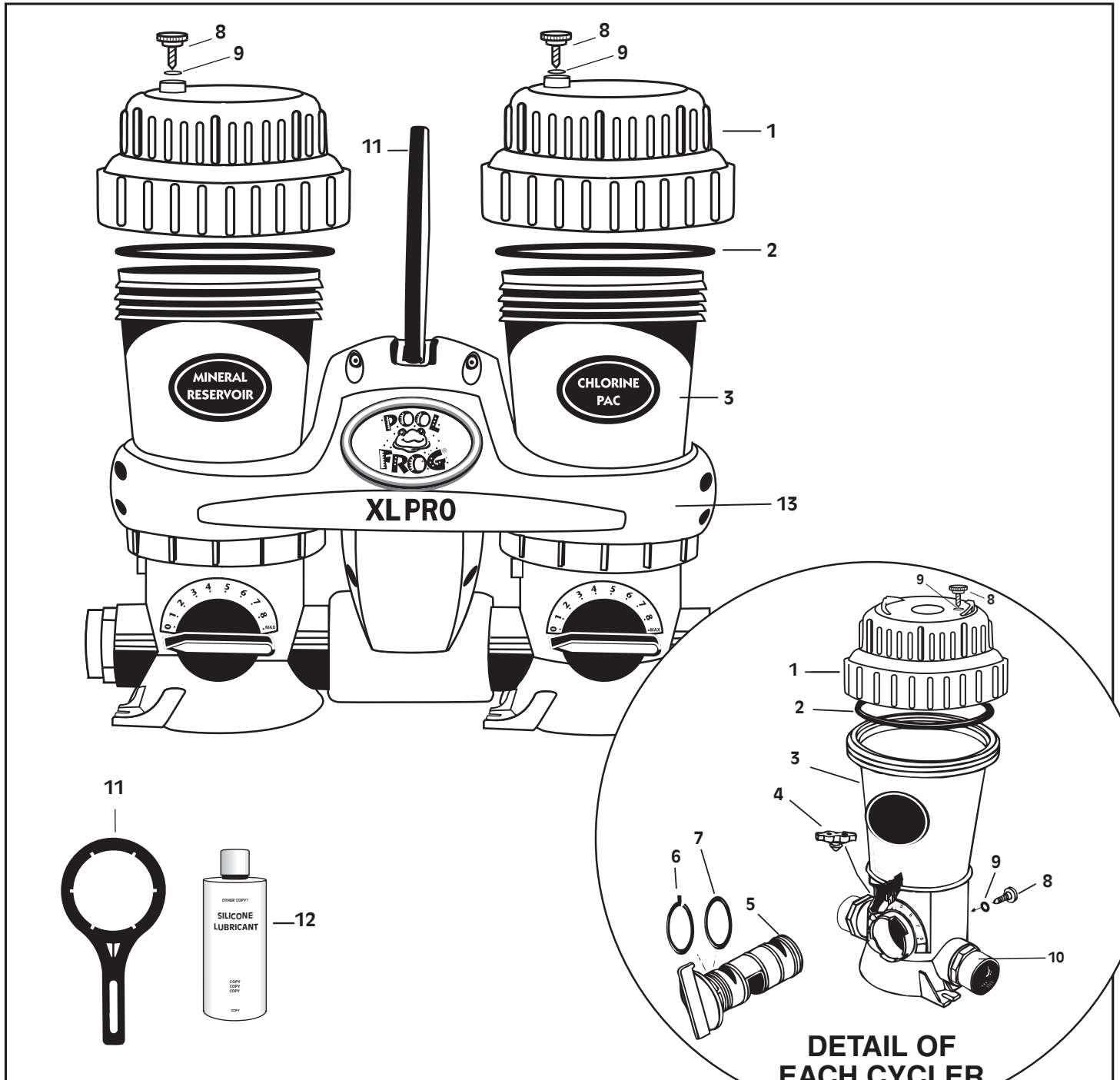

INCLUDED WITH POOL FROG® XL PRO CYCLERS

REF. #	DESCRIPTION	QTY. INCLUDED
1 & 2	Cap w/O-Ring	1
3	Body	1
4	Pressure Relief Valve	1
5, 6, 7	Control Dial with O-Ring & Snap Ring	1
8 & 9	Knob with O-Ring	4
10	2" Male Adapter	2
11	Cap/Control Dial Tool	1
12	Silicone Lubricant	1
13	Shroud	1

REPLACEMENT PARTS FOR POOL FROG® XL PRO CYCLERS

REF. #	PART NUMBER	DESCRIPTION
1 & 2	01-22-9412	Cap w/O-Ring
2	01-22-9920	Cap O-Ring
4	01-22-9480	Pressure Relief Valve
5, 6, 7	01-22-9440	Control Dial with O-Ring & Snap Ring
6 & 7	01-22-9450	Control Dial O-Ring Kit
8 & 9	01-22-9940	Knob with O-Ring
10	01-22-9490	2" Male Adapter
11	01-22-8870	Cap/Control Dial Tool
12	01-22-9971	Silicone Lubricant

POOL FROG® Cyclers Maintenance

Replacing the Control Dial O-Rings

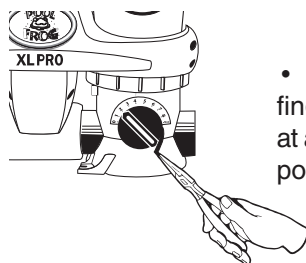
1. 

- Using a needle nose pliers, find the snap ring tail located at approximately the five o'clock position under the control dial.

2. 

- Pull down and out of the groove.

3. 

- Using a large screwdriver, loosen the control dial. Carefully pry the dial until it pulls out.

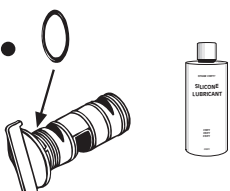
4. 

- Carefully replace the rubber o-ring without stretching it. Apply silicone lubricant, that came with your POOL FROG® XL PRO, on o-ring.

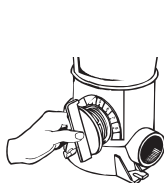
5. 

- Push control dial completely into the housing and turn the dial to setting 2.

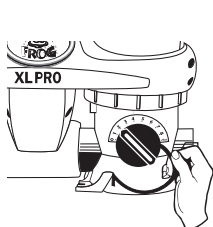
6. 

- Insert the non-lipped end of snap ring into the groove opening beginning at the 5 o'clock position and push it up so that it threads itself around the control dial.

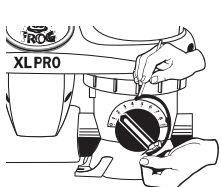
7. 

- Using a small screwdriver or pointed tool to help guide it, make sure the snap ring stays in the groove as it is inserted.

Replacing Cap O-Ring

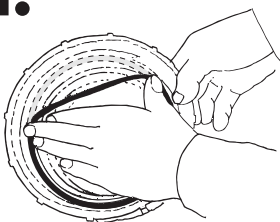
1. 

- Hold cap in front of you upside down with the o-ring groove facing up. Place one end of o-ring into cap groove at the point closest to you. Hold o-ring down with the thumb and index finger of one hand.

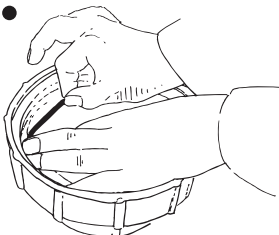
2. 

- Take hold of the far end of the o-ring with the thumb and index finger of the other hand. Roll o-ring slightly back towards you as you stretch the o-ring into the remainder of the cap groove.

3. 

- Lubricate o-ring often with silicone lubricant that came with your POOL FROG® XL PRO. DO NOT USE petroleum based lubricants.

Replacing Knobs

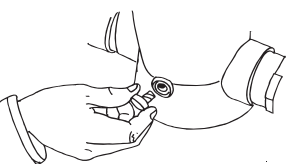
Back of Cyclers

- Replace knob in back or on cap of both POOL FROG® XL PRO Cyclers by unscrewing old one and screwing in new one.

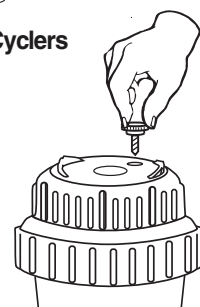
Or top of caps

Winterizing

1.



- Turn pump off and turn dial to Setting 0.

2.



- Remove both caps.

3.

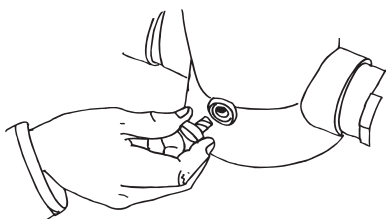

- Unscrew knob in the back of both POOL FROG® XL PRO Cyclers. Allow all water to drain.

4.

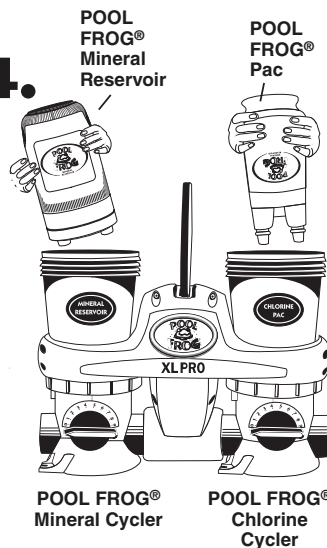

- Remove the POOL FROG® Mineral Reservoir and discard in trash. Even if you hear spent minerals inside, it is no longer effective.

Remove the POOL FROG® Pac. If it still contains chlorine, wrap in plastic bag and store in shed or cool, well-ventilated location away from children and pets.



Do not store near motorcycles, cars or anything metal that can rust, pit, etc.



- Make sure POOL FROG® Pac is away from open flame.

5.



- Replace both caps and knobs loosely.

In-line Installation

TOOLS NEEDED

Pipe Wrench

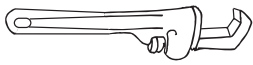

Hacksaw

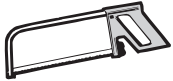

Tape Measure

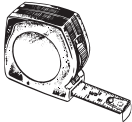

MATERIALS NEEDED

PVC Cement

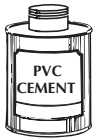

RECOMMENDED

Corrosion Resistant Check Valve

#10 x 1 1/4" Phillips Pan Head Screws with Washers

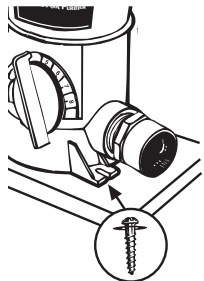

Use Phillips pan head screws through the mounting holes at the POOL FROG® Cyclor bases to secure the POOL FROG® XL PRO into a treated wood base.

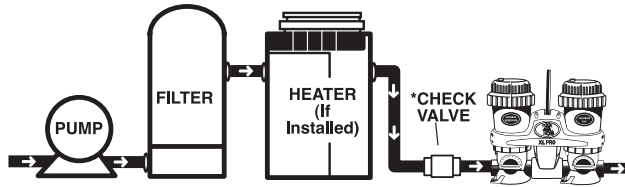

Install unit after all equipment and as far as possible from heater.



Do NOT install in copper pipe if using POOL FROG® Pac as chemical corrosion occurs.

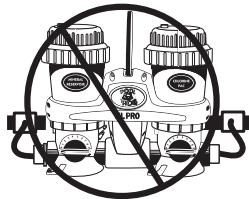

Do NOT install POOL FROG® XL PRO off-line.

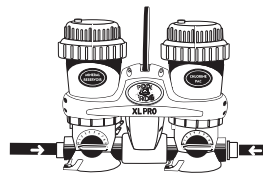

Bi-flow valve design allows water flow in either direction.

Minimum 12" above opening

Minimum 12" above opening

Minimum 12" to side

Minimum 12" to side

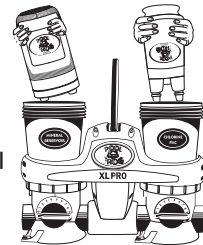

Allow a minimum of 12" above and on each side of POOL FROG® XL PRO to ensure room for easy replacement of POOL FROG® Mineral Reservoir and POOL FROG® Pac.

1.

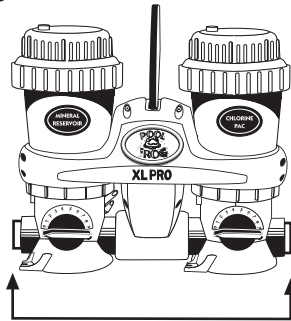

Measure the distance between outside male adapters and cut out a section of pipe 3" less than that dimension.

2.

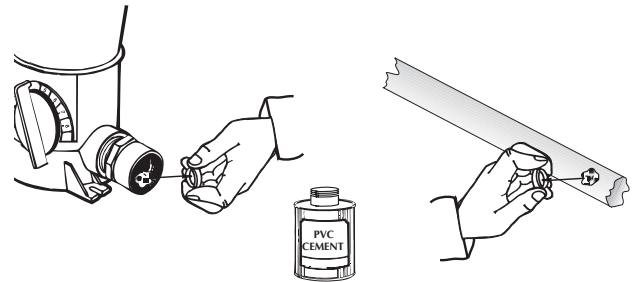

Following PVC cement directions brush PVC cement on the inside of the male adapters and to ends of the pipe.

3.

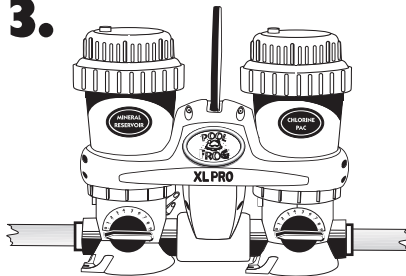

Insert PVC pipe into male adapters with a twisting action. Hold in place 5 to 10 seconds to bond.

4.

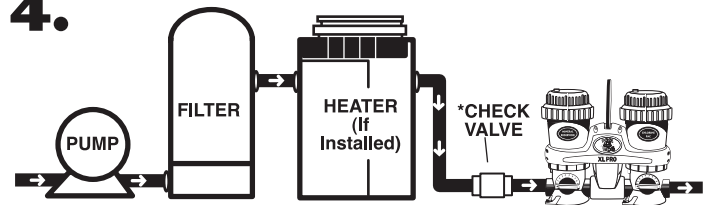

Isolating the POOL FROG® XL PRO by installing a corrosion resistant check valve is recommended.

For Proper Performance

1) Run pump for at least 6 hours per day at high speed (at least 40 gpm).

If the pump will run on low speed 24 hours per day or less than 6 hours per day on high speed, you must bleed the air while the pump is on by unscrewing the both cyclor cap knobs until water appears. Then screw the knobs back on. Repeat this process each time the cyclor caps are removed for any reason.

2) Install system with a minimum 4 psi back pressure.

Lower back pressures could result in under chlorination. Adjust eye ball fittings in the return jets to a smaller size to increase back pressure. Contact King Technology at 800-222-0169 for a cap tapped for a pressure gauge to determine back pressure at pool start-up.

3) Special installation:

- A. Water flow is higher than 80 gpm.
- B. In-floor cleaner is included with pool.
- C. Pool and spa combination with common equipment.

NOTE: Over chlorination or damage to the POOL FROG® Cyclers or other equipment could result if these special installations are not used in these situations.

A. With High GPMS Install T-fittings exactly as shown.

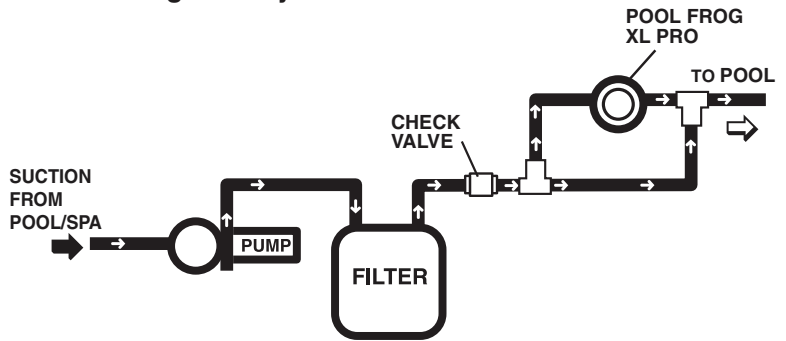

B. With In-floor Cleaners

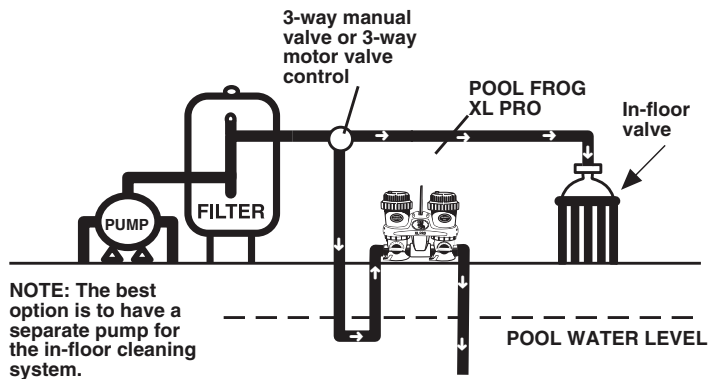

C. Pool and Spillover Spa Combination

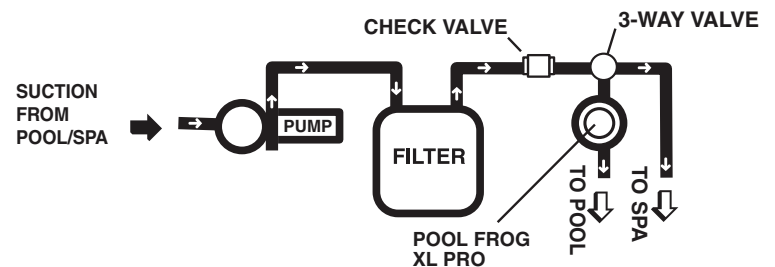

POOL FROG® XL PRO Two-Year Limited Warranty

King Technology, Inc. warrants to the original purchaser this unit will be free from any defects in workmanship and/or material, for a period of two (2) years from the date of original purchase. This warranty covers body, cap and control dial, but specifically excludes o-rings. King Technology at its option may replace any defective parts or the entire unit without charge after it is determined what is needed to correct any deficiency. Replacement parts with the exception of o-rings are warranted for the remainder of the original warranty. To extend the limited warranty from two years to ten years, simply complete the warranty card that came with your unit and return it to King Technology within 30 days of purchase and installation.

1. To obtain warranty service, you must deliver the unit to King Technology or its nearest authorized dealer. Shipping expenses are the purchaser's responsibility. The name of the nearest authorized dealer can be obtained by writing or calling King Technology at the address and telephone number provided below. Proof of purchase is required when requesting warranty service. Purchaser must present the sales receipt or other documentation verifying proof of purchase.

2. This warranty does not cover defects caused by: Modification, alteration, repair or service of the unit contrary to the accompanying instructions; physical abuse to or misuse of the product or operation or installation in a manner contrary to the accompanying instructions. This warranty also excludes all costs arising from the installation, adjustment, removal or replacement of defective units or parts. This warranty also excludes any and all claims arising out of the chemicals used in the product or their characteristics.

3. CAUTION - Read carefully – Failure to follow these instructions will void the warranty. Do not add shock in or near skimmer.

A. This unit is not designed for shock treatment of pools. See your pool dealer or distributor for further information concerning shock treatments.

B. Control dial settings higher than needed can result in excess sanitizers being discharged into the pool. If the sanitizer level goes unmonitored, it can result in bleaching or discoloration of areas around the pool inlet or in some cases bleaching or discoloration of the entire pool liner or paint.

C. Excess trichlor in the pool can create health hazards to bathers. Consult each chemical manufacturer's warnings and cautions for specifics.

D. Misuse or failure to use the proper POOL FROG® Mineral Reservoir and POOL FROG® Pac may cause damage to equipment or personal injury. This warranty will be null and void, if this unit is not used with the recommended POOL FROG® Mineral Reservoir and POOL FROG® Pac.

4. This warranty is the exclusive warranty for the POOL FROG® XL PRO. This warranty is not transferable. **KING TECHNOLOGY MAKES NO REPRESENTATION OR WARRANTY OF ANY KIND, EXPRESS OR IMPLIED, AS TO MERCHANTABILITY, FITNESS FOR A PARTICULAR PURPOSE OR ANY OTHER MATTER CONCERNING THE POOL FROG® XL PRO.** Any express warranty not provided herein, and any remedy for breach of contract but which for this provision might arise by implication or operation of law is hereby excluded and disclaimed. THE EXCLUSIVE REMEDY FOR ANY CUSTOMER IS THE REPAIR OR REPLACEMENT OF THE UNIT, AND THE RECOVERY OF DAMAGES WILL NOT EXCEED THE PURCHASE PRICE OF THE UNIT. IN NO EVENT WILL KING TECHNOLOGY BE LIABLE FOR ANY INCIDENTAL, CONSEQUENTIAL, SPECIAL OR PUNITIVE DAMAGES FROM ANY CAUSE.

5. Under no circumstance shall King Technology be liable to purchaser or any other person for any damage or loss incurred because of any chemicals used in the product or their physical characteristics, or interruption of service of the product, or any resulting special, incidental or consequential damages or losses. Some states do not allow the exclusion or limitation of incidental consequential damages, so the above limitation or exclusion may not apply to you.



Made in U.S.A.

Covered by one or more of the following U.S. Patent Numbers: 4,662,387; 5,076,315; 5,218,983; 6,210,566; 6,217,892; 6,383,507; 6,544,415; 6,551,609; 6,652,871 and other U.S. and Foreign Patents Pending.

Manufactured by: **KING TECHNOLOGY, INC.**
530 11th Avenue South, Hopkins, MN 55343 U.S.A.
952-933-6118 • 800-222-0169 • FAX 952-933-2206 www.kingtechnology.com

20-48-0220E
553100743R4N