

PG2000[®]

Installation Manual

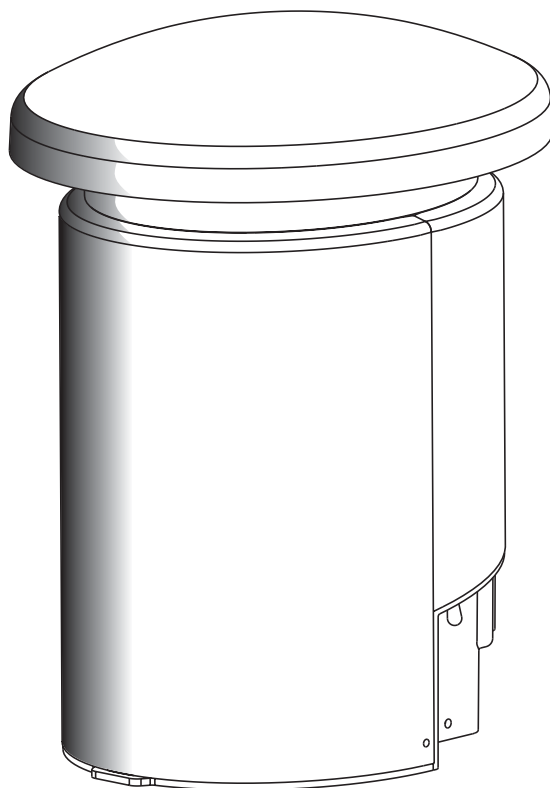

 **US LISTED**

Model No.s

840240

840241

840242

U.S. Patent Numbers
5,802,227; 5,825,954; 5,680,496;
6,002,216

Pentair Water Pool and Spa, Inc.

1620 Hawkins Ave., Sanford, NC 27330 • (919) 566-8000

10951 West Los Angeles Ave., Moorpark, CA 93021 • (805) 523-2400

Visit us on the Internet at: www.pentairpool.com or www.staritepool.com



IMPORTANT SAFETY INSTRUCTIONS

When installing and using this electrical equipment, basic safety precautions should be followed, including the following:

READ AND FOLLOW ALL INSTRUCTIONS

1. **WARNING:** To reduce the risk of injury, do not permit children to use this product unless they are closely supervised at all times.
2. Check your local building codes before installation to ensure the PG2000 is located at least 5 feet from the pool, or the minimum distance from the pool that local codes require.
3. The electrical supply for this product must include a suitable rated switch or circuit breaker to open all ungrounded supply conductors to comply with Section 422-20 of the National Electrical Code, ANSI/NFPA 70-2002. The disconnection means must be readily accessible to pool and spa users, but installed at least 5 feet (1.5m) from the pool or spa water.

⚠ WARNING



RISK OF ELECTRICAL SHOCK OR ELECTROCUTION

This PG2000 must be installed by a licensed or certified electrician in accordance with the National Electrical Code and all applicable local codes and ordinances. Improper installation will create an electrical hazard which could result in death or serious injury to pool users, installers, or others, due to electrical shock, and may also cause property damage.

Disconnect all power before starting the installation process to all associated pool equipment. Failure to do so may lead to severe electrical shock, which can result in death or severe personal injury.

⚠ WARNING

Before installing this **FIBERworks®** product, read and follow all warning notices and instructions accompanying this light product. Failure to follow safety warnings and instructions can result in severe injury, death, or property damage. You are going to be using a sophisticated device which requires knowledgeable handling in order to insure its optimum performance. **Please do not touch anything until you have read and understood these instructions.** If you have any questions, please call our service hotline, Monday through Friday, 7:30 a.m. to 4:30 p.m.: **(800) 831-7133**.

⚠ WARNING

It is recommended that **FIBERworks®** be installed by trained and certified **FIBERworks®** dealers only. This installation manual assumes that your PG2000 will be properly installed in full accordance with the instructions provided, the National Electrical Code, and any local codes applicable for an electrical installation of this type.

SAVE THESE INSTRUCTIONS.

Table of Contents

| | | |
|---------------|---|----|
| SECTION I. | Before You Begin Installation. | 4 |
| | The Installer's Ten Laws of FIBERworks® | 4 |
| | The Pool Designer/Salesperson's Ten Laws of FIBERworks® | 5 |
| A. | FIBERCAD Design Assistance | 6 |
| B. | Wide Angle Lens positioning with the PG2000 centered at end of the pool | 6 |
| C. | Wide Angle OptiFusion Lens positioning on the side of the pool with the PG2000 centered on side of pool | 6 |
| SECTION II. | Running Conduit | 8 |
| SECTION III. | Installing Lens Housings. | 9 |
| SECTION IV. | Preparing to Mount the PG2000 | 9 |
| SECTION V. | Feeding or Pulling the AmerGlow Cable | 11 |
| SECTION VI. | AmerGlow Lens Assembly | 12 |
| SECTION VII. | Installing the Ferrule Assembly | 17 |
| SECTION VIII. | Installing the PG2000 | 22 |
| SECTION IX. | Synchronization of SAm®/SAL® and Fiberworks® (Wiring Diagrams) | 25 |
| SECTION X. | Technical Data | 27 |

PG2000 Specifications

Electrical

Input Voltage 120 V @ 2 A

Power Consumption Approximately 200 Watts

Mechanical

Dimensions 15 in. x 10½ in. x 12 in.

Weight 20 lbs.

Materials High strength plastic

This unit will accommodate up to 600 FIBERworks® fibers.

Contents of the Shipping Carton

This package should contain all of the following items:

- √ PG2000®
- √ Sub-terrain Mounting Base
- √ Ferrule Kit
- √ PG2000 Installation Manual - (this manual)
- √ Owner's Manual
- √ Warranty Registration Card

To perform this installation, you will need the following items:

Electrical wire and conduit to connect main power, FIBERworks® cable and fittings as required, Professional Termination Kit, (p/n 21005500), and the tools/equipment listed in relevant sections of this manual.

SECTION I. Before You Begin Installation

The Installer's Ten Laws of FIBERworks®

1. DO NOT ATTEMPT INSTALLATION WITHOUT RECEIVING CERTIFIED TRAINING OR WATCHING INSTALLATION VIDEO.
2. Take your time and be patient when terminating - Rushing a 90 second FiberKnife 400 fiber termination can cause 30% loss of light.
3. Use only prescribed Termination tools - FIBERworks® FiberKnife and shield.
(DO NOT USE MECHANICAL CUTTERS OR KNIFE BLADE HEATED WITH TORCH.)
4. Make conduit runs as direct as possible - plastic fiber loses 2% of light per foot; see Table 1, Light Transmission Versus Distance.
5. When handling the cable do not bend final 12 in. of cable before lens.
6. Push lens and final 1 in. of cable into lens body - DO NOT PULL IN!
7. Sub-terrain Mounting Base should be installed below grade so that bottom of PG2000 is at or slightly above finished landscape or concrete grade and protected from grass.

Locate the PG2000 above water level whenever possible. If raised water features are being lit, be sure the end of the conduit inside the Generator is filled with RTV, other suitable sealant or conduit seal kit #22002000 and locate the Generator so water will drain away from it and not accumulate inside of or around the PG2000. This will prevent water from flooding the electrical portion of the unit.
8. Be sure conduits are located by cable size as in the template in the back cover of this manual and cut off level with top of Sub-terrain Base (finished grade).
9. PROPER TERMINATION AT PG2000; see PG2000 Installation Steps.
 - a. First, mechanically cut all cables to equal length about 14 in. above the top of the Sub-terrain Base.
 - b. Strip all cable jackets 0-2 in. above Sub-terrain Base.
 - c. SANITY SAVER- one wrap of electrical tape over fiber bundle end.
 - d. Install ferrule and tighten with 3-4 in. of fiber extending out of fiber disk; see Picture 9, pg. 20.
 - e. Hot knife cut. Hold blade angled at 15 degrees, as if you were cutting cream cheese. Don't stop and restart, but rather keep continuous light pressure. Don't saw or wiggle knife. Ease up pressure as you come to end of cut.
 - f. Be sure ferrule is fully rotated and secured by ferrule thumb screws.
 - g. Wrap electrical tape or tie wrap around bundle at 2-3 in. above conduit.
10. WHEN IN DOUBT CALL your FIBERworks® Specialist or Technical Service at 800-831-7133.

The Pool Designer/Salesperson's Ten Laws of FIBERworks®

1. The color of fiber optics is fantastic... but don't just sell fiber optics, sell FIBERworks®! More Light... More Color... More Friendly than other similar fiber optic systems... from the World's Leading Manufacturer of Underwater Lights!
2. Delight your customers and get referrals. Don't undersize - never use fewer fibers or fewer lights than recommended.
3. The Longer the fiber optic cable, the more it will cost and the less light it will transmit to the pool, spa, water feature or landscape light. Distance costs 2% of light per foot; see Table 1, Light Transmission Versus Distance.
4. Choose your PG2000 location(s) wisely. Give your biggest cables the shortest runs. If you design "never ending" decks, design a planter between 5 and 10 feet (depending on code) from the primary lens location.
5. Colored surfaces absorb light. The darker the surface, the more light it will absorb. Do not waste your customer's money on underwater fiber optics for dark surfaces. They will not fully appreciate the dramatics of fiber optic colors. Use Amerlites®, AquaLights® or HiLites®.
6. The darker your pool surface, the more dramatic will be perimeter FIBERworks®. Dark pools make great reflecting pools and fantastic perimeter FIBERworks pools. For perimeter installations over 200' consult your FIBERworks® Specialist.
7. FIBERworks® powerfully illuminates the wall and floor surface toward which the lens is pointed... modest illumination is on the wall which holds the lens. AmerGlow 12, 30, 50, 70 or 100 cables make great step lights and shadow fillers when directed toward or across the wall holding the AmerGlow 325, 225 or 170 cables.
8. There are two underwater lenses available. The Wide Angle Lens spreads light about 180 degrees and should be used for most underwater applications. The Standard Lens spreads light about 70 degrees and should be used for opposite wall shadow filling, up lighting into a fountainhead, and up lighting into a waterfall or cascade.
9. Always use Certified FIBERworks® Installers. A rushed or poor installation can kill performance by 30%. Schedule training as soon as possible or order FIBERworks® Installation Video [P/N P3-202].
10. WHEN IN DOUBT CALL Technical Service at 800-831-7133 OR- complete a FIBERCAD FORM (located in the Pentair Water Pool and Spa, Inc. Catalog), AND fax a scale drawing to 727-461-5080.

NOTE

FIBERworks Application Manual is available on-line @ www.pentairtraining.com and www.pentairpool.com.

A. FIBERCAD Design Assistance.

NOTE

FIBERworks Application Manual is available on-line @ www.pentairtraining.com and www.pentairpool.com.

For assistance in designing your fiber optic lighting, fax a FIBERCAD form (located in the Pentair Water Pool and Spa, Inc. Catalog) and scale drawing to 727-461-5080.

If designing your own lighting layout, it is critical to keep the PG2000 as close to the pool as possible (less than 15' is desirable) and cable runs as short as possible to maximize light output; see Table 1, Light Transmission vs Distance.

B. Wide Angle Lens positioning with the PG2000 centered at end of the pool.

1. AmerGlow 170, 225 and 325 only, with the lens(es) positioned at the end of the pool. Whenever possible, the lens(es) should not face directly toward the home or entertainment area.
 - a. For white or nearly white concrete, fiberglass or vinyl pools, Wide Angle Lenses intended to illuminate the entire length of the pool can be placed in either the shallow end or deep end 6 to 8 inches below water level.
 - b. For light or medium colored pools, place the Wide Angle lens(es) in the deep end 6 to 8 inches below water level.
 - c. Use single AmerGlow 170, 225, 325 in center of end wall or Dual AmerGlow 170's or 225's each 2 to 3.5 feet from center line (4 to 7 feet apart). Pools over 18 feet wide should have dual lenses in the end wall.

C. Wide Angle OptiFusion Lens positioning on the side of the pool with the PG2000 centered on side of pool.

1. AmerGlow 100, 70, 50 and 30 only, unless pool is over 20 ft. wide, with the lens(es) positioned at the side of the pool. Whenever possible, the lens(es) should not face directly toward the home or entertainment area.
 - a. Lenses should be located and directed to offer uniform illumination of the entire pool allocating more light for areas with greater floor and wall surface area such as the deep end. Also see Light Transmission vs Distance table for more help.
 - b. The best lighting is achieved on the surfaces the lens is facing.
 - c. Lens(es) in concrete or fiberglass pools should be located approximately 1/3 of the distance between the water surface and the beginning of the transition from wall to floor.
 - Place 9 in. below water level in 3 foot shallow ends to reduce the intensity of hot spots on the floor.
 - d. In vinyl pools, locate lens(es) as follows:

| DEPTH | INCHES BELOW TOP OF PANEL |
|--------|---------------------------|
| 3 ft. | 12 in. |
| 4 ft. | 12 in. |
| 5 ft. | 15 in. |
| 6 ft. | 15 in. |
| 7 ft. | 18 in. |
| 8 ft. | 18 in. |
| 9 ft. | 21 in. |
| 10 ft. | 21 in. |

| TABLE 1. | | | | | | | | | |
|--|-------------------------|-------------------------|-------------------------|-------------------------|------------------------|------------------------|------------------------|------------------------|------------------------|
| FIBER EQUIVALENT LIGHT TRANSMISSION at 10 ft. | | | | | | | | | |
| AMERGLow CABLE SIZES | | | | | | | | | |
| Cable Length | 325 fiber equiv. | 225 fiber equiv. | 170 fiber equiv. | 100 fiber equiv. | 70 fiber equiv. | 50 fiber equiv. | 30 fiber equiv. | 12 fiber equiv. | % of Light Lost |
| 10 | 325 | 225 | 170 | 100 | 70 | 50 | 30 | 12 | |
| 12 | 312 | 216 | 163 | 96 | 67 | 48 | 29 | 12 | 4.0% |
| 14 | 300 | 208 | 157 | 92 | 65 | 46 | 28 | 11 | 7.8% |
| 16 | 288 | 199 | 151 | 89 | 62 | 44 | 27 | 11 | 11.4% |
| 18 | 276 | 191 | 145 | 85 | 60 | 43 | 26 | 10 | 14.9% |
| 20 | 266 | 184 | 139 | 82 | 57 | 41 | 25 | 10 | 18.3% |
| 25 | 240 | 166 | 126 | 74 | 52 | 37 | 22 | 9 | 26.1% |
| 30 | 217 | 150 | 113 | 67 | 47 | 33 | 20 | 8 | 33.2% |
| 35 | 196 | 136 | 103 | 60 | 42 | 30 | 18 | 7 | 39.6% |
| 40 | 177 | 123 | 93 | 55 | 38 | 27 | 16 | 7 | 45.4% |
| 45 | 160 | 111 | 84 | 49 | 35 | 25 | 15 | 6 | 50.7% |
| 50 | 145 | 100 | 76 | 45 | 31 | 22 | 13 | 5 | 55.4% |
| 55 | 131 | 91 | 68 | 40 | 28 | 20 | 12 | 5 | 59.7% |
| 60 | 118 | 82 | 62 | 36 | 25 | 18 | 11 | 4 | 63.6% |
| 70 | 97 | 67 | 51 | 30 | 21 | 15 | 9 | 4 | 70.2% |
| 80 | 79 | 55 | 41 | 24 | 17 | 12 | 7 | 3 | 75.7% |
| 90 | 65 | 45 | 34 | 20 | 14 | 10 | 6 | 2 | 80.1% |
| 100 | 53 | 37 | 28 | 16 | 11 | 8 | 5 | 2 | 83.8% |

This table shows the effect of longer cable runs on light transmission. Longer cable runs have the same effect as cutting down on the number of fibers.

** The first 10' is considered unavoidable and is used here as a standard for comparison.

(For example: 69' of 325, 50' of 225 and 37' of 170 all have the same output as 10' of 100.)

| ⚠WARNING |
|---|
| Provide adequate lighting to your pool for nighttime use. The amount of light needed will vary with the size and shape of the pool. This may require additional lighting sources. Failure to provide adequate lighting can result in swimming and diving hazards that can cause severe injury or death. Consult your local building department or a lighting professional to determine lighting requirements. |

SECTION II. Running Conduit

A. General conduit tips.

- Use electrical sweep elbows and 45's or heat bend PVC pipe. DO NOT use plumbing 90° or 45° elbows. Using the right conduit and fittings will allow the cable to be fed much easier, and will prevent damage to the fiber optics.
- Use rigid PVC pipe or SMOOTH ID flexible electrical PVC for all cable runs. Flexible water PVC pipe is not recommended for this type of installation because of its high friction walls.
- Make your job easier - use electrician's lube when feeding cable.

B. Choosing the best size conduit for the job.

- a. For AmerGlow 325, 225 or 170 use 1 in. or larger rigid PVC conduit; use 1½ in. for AmerGlow 325 over 20 ft.
- b. Use ¾ in. or larger conduit for AmerGlow 100 or 70.
- c. Use ½ in. or larger conduit for AmerGlow 50, 30 or 12.

NOTE

Do not reduce fiberglass lens housing or standard gunite lens housing to less than 1 in. in rear socket or lens assembly will not seat properly.

C. Electrical conduit requirements, see Wiring the PG2000 for Wiring Diagram.

- a. For manual operation at PG2000, RF2000 Wireless Control or single remote toggle switch operation, use ½ in. electrical conduit to run 3 - 18 AWG (black, white and green) or larger wires to each PG2000 location.
- b. For dual remote toggle switch or automated remote control operation (Compool, etc.), use ½ in. electrical conduit to run 4 - 18 AWG (red, black, white and green) or larger wires to each PG2000 location.
- c. It is very important that the unit be properly grounded - there is serious risk of electrical shock or electrocution otherwise.

⚠ WARNING



The PG2000 must be properly grounded. Consult the National Electrical Code and all other applicable local codes and ordinances for proper grounding techniques. Improper installation will create an electrical hazard which could result in death or serious injury to pool users, installers, or others, due to electrical shock, and may also cause property damage.

- d. Make sure the conduit comes up in the correct area in the front of the PG2000; see Section IV for this information.
- e. Extend conduit up above the bottom of the PG2000 at least six inches.

D. Running the conduit for AmerGlow fiber optic cable.

- a. Using the sizes determined above, run the conduit from the pool wall to the PG2000 location.
- b. Conduit near the PG2000 should be at least 4 in. deep if using the sub-terrain mounting base to mount the PG2000.
- c. Use only electrical sweep elbows and 45's - DO NOT use plumbing 90's or 45's, as they can damage the fiber optics or prevent pulling the cable.
- d. The lens body should be located according to recommendations in the "Before You Begin Installation..." Section. Conduit should slope to that depth.
- e. If using smaller than 1 in. conduit, do not bush down within 2 in. from rear of lens body.
- f. Use a 12 in. minimum straight section of conduit behind the lens housing.
- g. For gunite pools, the recessed cut back for lens housing should be as shown in Figure 1. Dimension "A" should be 1 in. for a FIBERworks Standard Gunite fitting, and 1½ in. for a FIBERworks Invisible Gunite fitting.

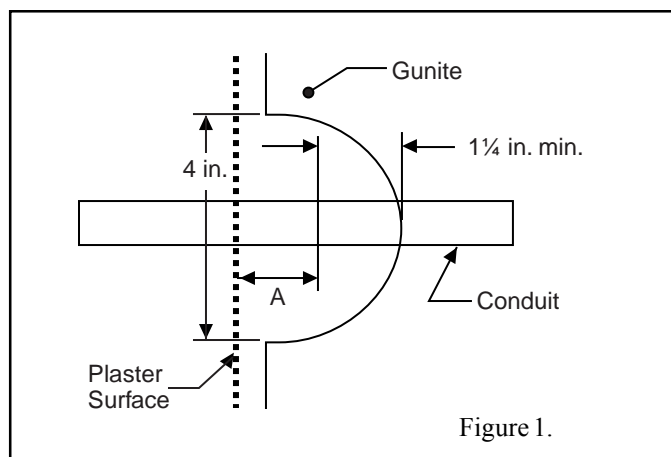

Figure 1.

- h. At the PG2000 location, leave at least 6 in. of conduit above the anticipated sub-terrain mounting base or deck surface and place tape over both ends of conduit. The tape and extra length will help prevent debris from getting into the conduit until the cable is run. The conduit should be cut off level with top of Sub-terrain Base (finished grade) location just before the fiber optic cable is run (does not apply to electrical conduit).
- i. Use the **template on the back page of this manual** to determine conduit location inside the PG2000 if you are installing on a poured concrete deck, on a wood deck or in the ground.
- j. For either type of installation, use duct tape or tie wrap to bundle the conduit together in the PG2000 area. Keeping the conduit together will help when preparing the cable later.

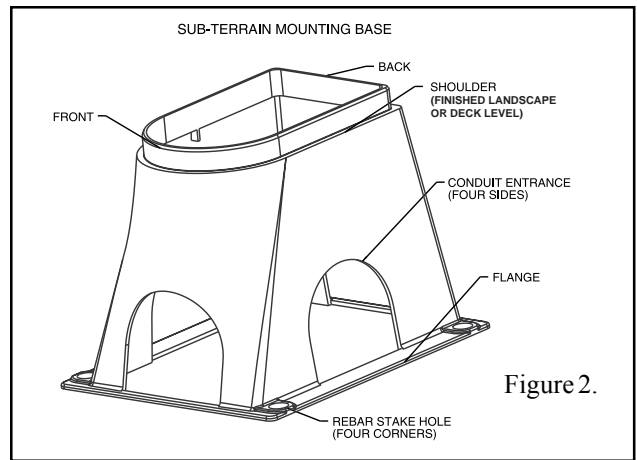

Figure 2.

SECTION III. Installing Lens Housings

- FIBERworks® lens housings are installed the same way regular water return fittings are installed.

⚠ CAUTION

Use only FIBERworks lens housings. Other fittings will not seal conduit. Each FIBERworks lens housing has a label identifying it as such. Do not use excessive glue, as the overflow may run onto the O-ring sealing surface.

SECTION IV. Preparing to Mount the PG2000

A. Choose one of the following two methods for installation of the PG2000.

1. Mount the PG2000 on **BURIED** Sub-terrain Mounting Base (included). This allows the unit to be located away from the deck, for example, in a garden near the pool, among some shrubbery, etc. Be sure the unit is situated such that the air vents are not going to be blocked by overgrowth. The sub-terrain mounting base can also be poured into the concrete deck or pad.
2. Mount the PG2000 directly onto a flat concrete surface or a wood deck without the Sub-terrain Base using the lag screws, washers and anchors (included).

B. Installing the Sub-Terrain mounting base; see Figure 2 and Pictures on pg. 10.

1. If conduit has already been run, set mounting base over top of conduit to determine if the bottom flange or side arches need to be cut. The top shoulder of the base should be at or slightly above finished landscape or deck level.
2. Leveled base can be secured in place with 3/8 in. rebar angled through holes provided in corners of bottom flange, see Picture 3 on pg. 10
3. Cut fiber conduit below or at top of base and cut electrical conduit 6 in. above finished landscape or deck level, see Figure 2. See PG2000 Conduit Template on pg. 28 of these instructions.

Note

Flat side of base is back of the PG2000. Locate this side away from line of site to the PG2000.

C. Mounting to a wood deck or a poured concrete surface.

1. What you'll need:
 - √ Drill with 1/2 in. Masonry Bit
 - √ Hammer
 - √ 1/2 in. Nut Driver

(continued on page 11)

Sub-terrain Base & Deck Installation

Tools and Material Required:

- ✓ Hammer
- ✓ Side Cutters
- ✓ Phillips Screwdriver
- ✓ Hacksaw or PVC Cutters
- ✓ Four 12 in. lengths of 3/8 in. Rebar or Rod
- ✓ Drill with 1/2 in. Concrete Bit
- ✓ Ratchet Driver w/4 in. Extension
- ✓ 1/2 in. Socket



1. Conduits set per PG2000 template.



2. Cut sub-base flanges as needed.



3. Drive 3/8 in. rebar at an angle in the corners.



4. Backfill 1 to 4 in. below shoulder for mulch or concrete. Cut fiber conduit below or at top of base.

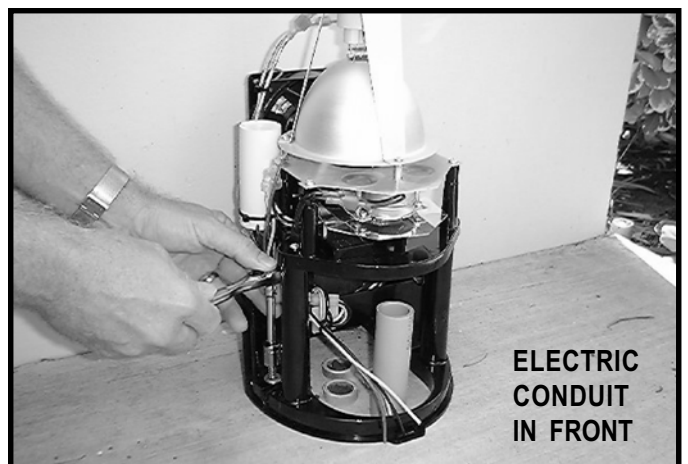

5. For concrete deck mount, drill for two 1/2 in. lead shield anchors provided and secure with lag screws and washers provided.

2. Installing the PG2000 directly to deck.
 - a. Cut fiber optic conduits ½ in. above the deck. Cut electrical conduit 6 in. above deck, see PG2000 Conduit Template on pg. 24 of these instructions.
 - b. Remove outer body from PG2000 by removing one black #6 screw on each side at bottom. Carefully lift outer body up and set aside with screws placed inside for safe keeping.
 - c. Set PG2000 subassembly on deck over conduit with electric conduit all the way to the front.
 - d. On concrete, mark two holes in deck and drill for provided anchors using ½ in. masonry drill bit. Tap anchors into holes.
 - e. Set PG2000 subassembly aside until cables are run.

SECTION V. Feeding or Pulling the AmerGlow Cable

A. What you’ll need:

- √ Electrical Tape
- √ Fish tape (optional)
- √ Electrician’s lube (optional)

B. Tips, tricks and traps.

- Use electrician’s lube on the cable, to help it through the conduit. Though not necessary, it can make the task easier and quicker.
- Cover the end of the cable with electrical tape, or similar, to make a pilot tip. This will make guiding the cable through the conduit easier. This applies whether pushing the cable through from the pool side, or pulling it with fish tape.
- At the PG2000 location, after the cable is pulled and lenses are set, seal the conduit around the cables with RTV silicone caulking or conduit seal kit #22002000. This will help keep debris out of the conduit during the rest of the installation, and provide an added precaution to prevent water from entering the PG2000 should the conduit develop a leak during its lifetime.
- Leave about 1 foot of cable extending past the end of the lens housing at the pool (only necessary if installing lens on job location).
- Once the cable is finished and the lens is installed at the pool end, you should have a minimum of 15 in. extending up above the PG2000 mounting location. This will allow easier installation into the PG2000. Also, a few extra inches in the fiber bundle will accommodate fiber re-termination if the fiber ends were to become damaged over years of service. Additionally, it allows for later addition of fibers for landscape or pool lighting.
- If the lens assembly and/or PG2000 are not to be installed immediately, tape the ends of the cable to protect the fiber.

⚠ CAUTION

On factory pre-cut cable, avoid manually bending the first 12 in. of cable on the lens side. This can disturb the factory termination and prevent maximum performance of the system.

- Know your cable length - do not underestimate the cable length required. Allow 15 in. extra for pre-cut cable and 19 in. for bulk cable from pool wall to bottom of PG2000. (Top of Sub-terrain Base.)

C. Pulling or feeding pre-cut cable.

1. For Standard Gunitite lens housing and Fiberglass lens housing remove the spacer and spacer O-ring using diagonal-cutters.
2. Remove the reminder tag from the cable.
3. If needed, push the fish tape through the conduit from the PG2000 side.

NOTE

In many cases, AmerGlow cable may be fed through conduit without the use of a fish tape.

4. Attach the cable to fish tape at the poolside with duct or electrical tape, cover the fibers completely with tape.
5. Reel up fish tape while second person pushes the cable from the pool side. If necessary, apply electrician's lube on the cable as it is fed through.
 - a. Keep the last foot of cable on the lens side as straight as possible.
 - b. Be careful not to damage the lens assembly.
6. Stop feeding the cable when one foot is left on the pool side.
 - a. Make sure the lens O-ring and spacer O-ring (if applicable) are in position and clean.
 - b. Clean the O-ring sealing surface on the inner flange of the lens housing.
7. Continue to pull the cable until the lens assembly is 1 in. away from the seated position.

| |
|--------------------|
| <h3>⚠ CAUTION</h3> |
|--------------------|

| |
|---|
| DO NOT snug the lens into place by pulling on the cable! This may cause the cable to pull away from the lens, and will impair performance of the Termination. |
|---|

8. Place the lens retaining nut onto the lens and PUSH the lens into place.
9. Hand tighten the lens using the lens tightening tool, until the O-ring is seated.
 - a. For standard gunitite and fiberglass lens housings (which do not use the spacer and spacer O-ring), **hand tighten** ¼ turn past the seated O-ring position.
 - b. For Invisible Gunitite and Vinyl Liner housings (which use the spacer and spacer O-ring), **hand tighten** the lens retaining nut ½ turn past the O-ring's seated position.

D. Pulling or feeding bulk cable.

1. Push the fish tape through the conduit from the pool end. In many cases, AmerGlow cable may be fed through conduit without the use of fish tape.
2. Attach the cable to the end of the fish tape using duct or electrical tape. Cover the fibers completely with tape. Pull cable through conduit using electrician's lube if needed.
3. Leave about one (1) ft. of cable extending past the lens housing, and about one (1) ft. above the PG2000 mounting surface. If desired, leave cable on spool and cut to exact length after lens is assembled.

SECTION VI. AmerGlow Lens Assembly

A. What you'll need:

- √ Fiber Termination Kit, P/N 21005500. Contains: cable stripper, hot knife, spare blades, cutting shield, lens tightening tool, and OptiFusion gel.
- √ Cable Cutters
- √ Wire snips
- √ Channel locks
- √ Crescent wrench
- √ Electrical Tape

B. Preparing the cable.

NOTE

There should be about 1 foot of cable sticking out of the lens housing at this point.

⚠WARNING

FiberKnife reaches extreme temperatures. Grasp only by the handle. Failure to follow these directions can lead to severe burns.

1. Plug in the FiberKnife and set it on the stand provided.
 - a. Let the knife warm up for 15 minutes. This is especially important for larger cable sizes.
 - b. Keep the knife out of the wind while warming, as the breeze can cool it off.
 - c. Allow at least 5 minutes between large cable cuts for the knife to reheat.
2. Use the cable stripping tool to strip back 1 in. of the cable jacket, see Picture 1 on pg. 14.

⚠CAUTION

DO NOT damage any of the fibers. If the fibers are nicked they can break, reducing light output.

- Practice on some spare cable a few times. With a little practice, you will be able to make good cuts with this stripper.
- There is an extra blade inside the stripper handle.

- a. Adjust the stripper and practice a few times on an extra piece of cable if you haven't used it before. The blade should be exposed about the thickness of the cable jacket.
 - b. Adjust the cutting depth by turning the black knob on the end of the cable stripper.
 - c. Push the spring tension guide open with thumb, and place stripper on cable as shown in Figure 3.
 - d. Rotate the stripper around the cable with the black knob turning toward opening; as shown in Figure 4.
 - e. The cable stripper blade is directional - if it does not cut properly, be sure that the blade is in correct orientation.
 - f. Once jacket is almost separated remove stripper and bend jacket to finish separation and remove jacket.
 - g. Fan the fiber ends to remove the excess powder from them.
3. If you are installing an invisible gunite or vinyl liner lens housing, place the spacer with spacer O-ring onto the cable - the direction is indicated on the spacer.
 4. Assemble the seal nut; see Figure 5.

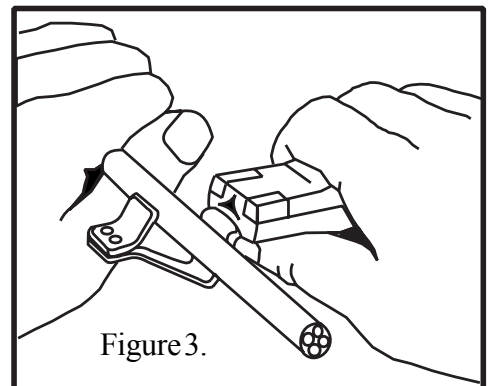

Figure 3.

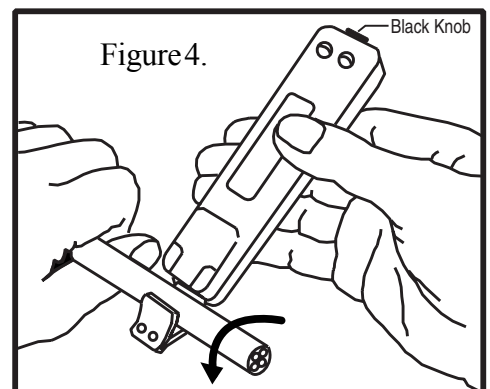

Figure 4.

Black Knob

- a. Wrap electrical tape around the end of the fibers.
- b. Slide the compression nut onto the cable with the threads toward the end.
- c. Choose the correct grommet size and slide it onto the cable until 1/16 in. past the edge of the jacket. The cable size is molded onto the back of the grommet.
- d. Straighten the cable coming out of the lens housing, and try to keep it straight from this point on.
- e. Place the seal nut over the grommet and tighten compression nut.

(continued on page 15)

AmerGlow Lens Assembly

Tools and Material Required:

- ✓ Cable Stripper
- ✓ Crescent Wrench
- ✓ Hot Knife
- ✓ Cutting Shield
- ✓ Lens Tightening Tool
- ✓ Electrical Tape
- ✓ OptiFusion Gel (Standard Lens)



1. Remove 1 in. of the jacket with the stripper.

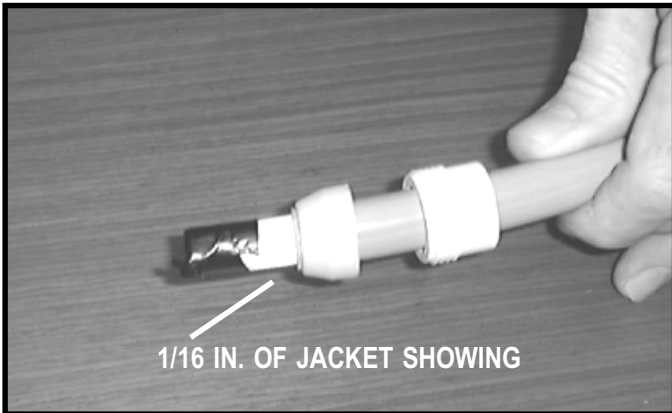

2. Add tape, spacer (if needed), compression nut and grommet.

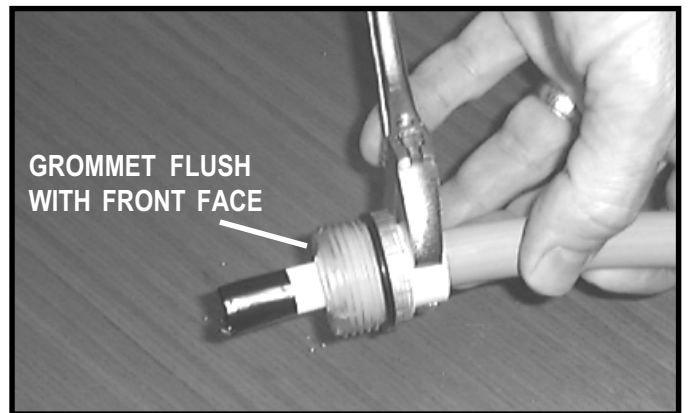

3. Add seal nut and tighten.

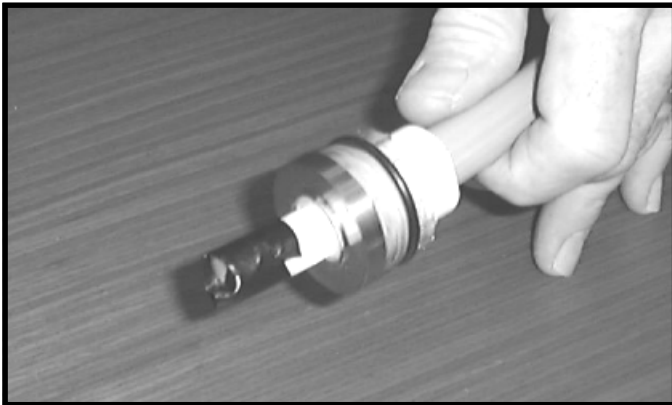

4. Screw on cutting shield.



5. Angle hotknife 15 degrees.



6. Fill Standard Lens reservoir with gel. (No gel required in Wide Angle Lens.)



7. Slowly screw on lens cap.

AmerGlow Lens Assembly Installation Steps, continued.



8. Cable in fitting, use a spacer if needed.

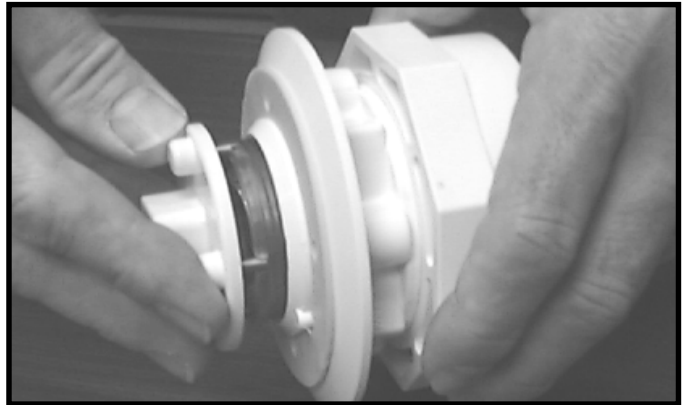
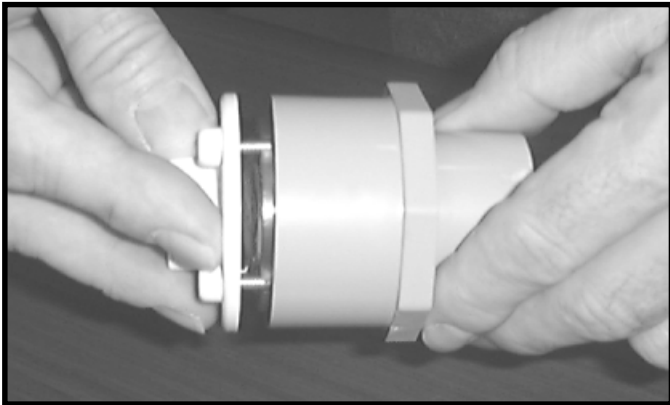

9. Hand-tighten the retainer nut.

- (4. e.)
- Hold the seal nut stationary with your hand and rotate the compression nut using a crescent wrench.
 - If you use channel locks to hold the seal nut, be careful not to damage the O-ring.
 - Tighten the compression nut until the grommet is flush with the front surface of the seal nut (for smaller cables) or there is only one thread left showing on the compression nut (for larger cables).
 - Pull on the completed assembly to be sure cable does not move.

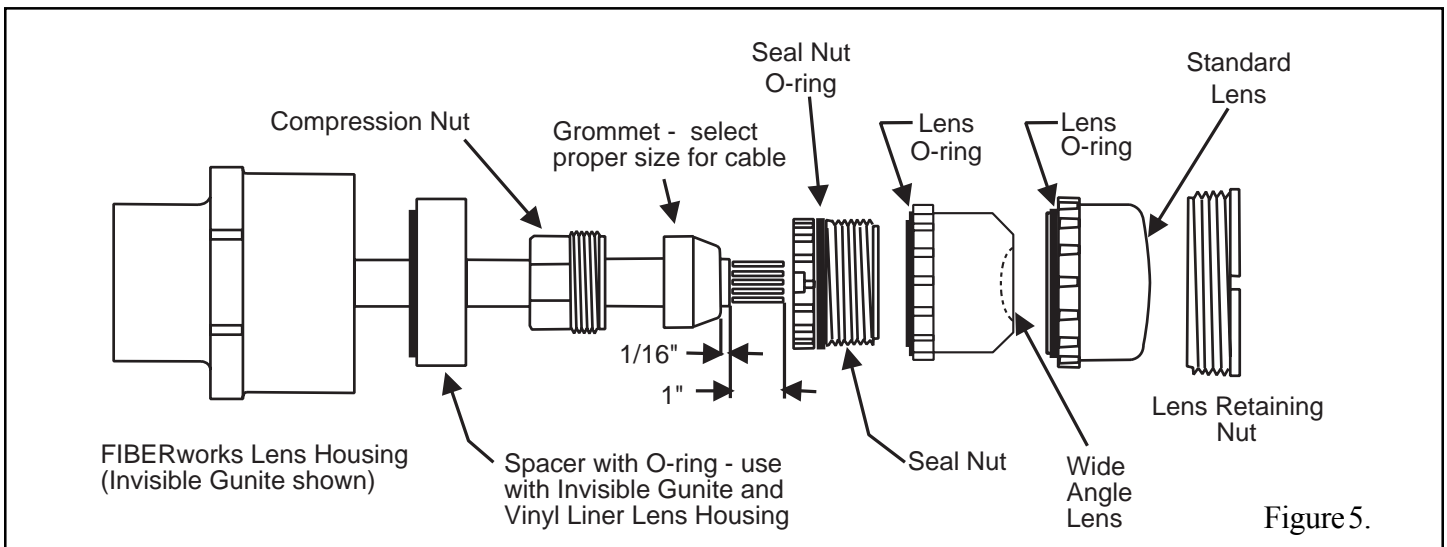

5. Cut the fiber.

Note

This is the most critical step for a successful installation.

- a. Screw the Cutting Shield onto the seal nut until it bottoms out. At this point, only fiber should be sticking out past the edge of the cutting shield. If jacket or grommet is sticking out, disassemble seal nut assembly and adjust the grommet position.
- b. Hold the cable at the seal nut, keeping the cable straight.

⚠CAUTION

DO NOT use too much force - you will only damage the FiberKnife and/or your cut. Let the heat of the knife do the cutting.
DO NOT saw, wiggle or rotate the blade back and forth.
On the larger cables, it may help to rotate the handle side of the blade downward slightly.

- Place the blade against the cutting shield at a 10-15 degree angle; see Figure 6.
- Press with a light to moderate constant pressure using the cutting shield ring as a guide.
- Ease up towards the end of the cut to keep the last few fibers from folding over.

6. Remove the Cutting Shield.

⚠WARNING

Shield may be hot. Exercise caution when removing it. Failure to do so could cause burns.

7. Inspect the cut.

- a. The cut should be smooth and flat, with no visible lines or surface bubbles. When training and performing your first cuts, using a small magnifying glass can help see imperfections that may be difficult to see with the naked eye.
- b. A good professional cut is critical to the performance of the fiber optic system.
- c. There are several things which can cause a bad cut:
 - The cable jacket was not completely stripped back.
 - Sawing or wiggling the blade during cutting, or incorrect blade angle.
 - Burrs on the edge of the cutting shield.
 - The FiberKnife is not warmed up enough. Allow enough time between cuts for the knife to reheat, and keep it out of the wind while it is heating.
 - The blade needs replacing about every 15 - 20 cuts; replacement pack of 3 blades, P/N 21005600.

C. Installing lenses

1. Wipe the fiber face with an Optic Prep Pad or a clean cloth to remove any residual powder.
2. If using the Standard Lens, fill the entire gel cup located on the inside of the lens with OptiFusion gel until it crests above the gel cup edge. If using the Wide Angle Lens, **NO GEL IS REQUIRED**, see Picture 6 on pg. 14.
3. Assemble the lens to the seal nut.
 - a. Make sure the lens and seal nut O-rings are clean and in place.
 - b. Hold the compression nut with a wrench and hand tighten the lens onto the seal nut until lens bottoms out. Keep the end of the cable straight during this step.

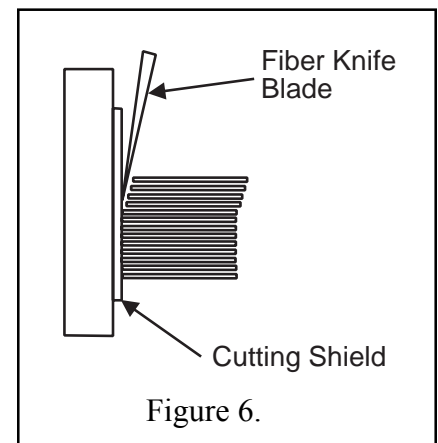

4. Install the lens into the lens housing.
 - a. If applicable, make sure the spacer and spacer O-ring are in position and clean. The spacer is marked “This Side Toward Pool”.
 - b. Clean the O-ring sealing surface on inner flange of lens housing.
 - c. Feed or pull the cable until the lens assembly is about 1 in. away from the seated position.

⚠ CAUTION

DO NOT seat lens housing by pulling on cable. This may cause the cable to pull away from the lens, and impair light performance.

- d. Place the lens retaining nut onto the lens and **PUSH** the lens into place.
- e. Hand tighten the lens using the lens tightening tool, until the O-ring is seated.
 - For Standard Gunitite and Fiberglass lens housings (which do not use the spacer and spacer O-ring), **hand tighten** ¼ turn past the seated O-ring position.
 - For Invisible Gunitite and Vinyl Liner housings (which use the spacer and spacer O-ring), **hand tighten** the lens retaining nut ½ turn past the O-ring’s seated position.

FIBERworks makes your job easier:

For vinyl liner pools, the lens is sealed in the lens body before the liner is installed. You do not need to install the seal plate and cut your liner until the pool is completely filled.

SECTION VII. Installing the Ferrule Assembly, see Pictures on pg. 19

A. Preparing and installing the cable

⚠ WARNING

FiberKnife reaches extreme temperatures. Grasp only by the handle. Failure to follow these directions can lead to severe burns.

1. Plug in FiberKnife, and allow to heat for 15 minutes, out of the wind.
2. Mechanically cut all cables to equal length about 14 in. above the top of the Sub-terrain Base.
3. Use the cable stripping tool to strip back cable jacket 0 to 2 in. above the PG2000 base.
 - a. Adjust the stripper and practice a few times on an extra piece of cable if you haven’t used it before. The blade should be exposed about the thickness of the cable jacket.
 - b. Adjust the cutting depth by turning the black knob on the end of the cable stripper.
 - c. Push the spring tension guide open with thumb, and place stripper on cable as shown in Figure 3.
 - d. Rotate the stripper around the cable with the black knob turning toward opening; as shown in Figure 4.
 - e. The cable stripper blade is directional - if it does not cut properly, be sure that the blade is in correct orientation.
 - f. Once jacket is almost separated remove stripper and bend jacket to finish separation and remove jacket.
 - g. Fan the fiber ends to remove the excess powder from them.

B. Loading the fiber into the ferrule

1. Gather all of the stripped cable ends together evenly and apply **ONE** wrap of electrical tape around the fibers at the end.
 - a. Fan the fiber ends to remove any excess powder from between the fibers.

- b. Arrange the bundle so that the fibers from the primary pool/spa underwater lenses or perimeter cable are mixed together and lie in the center of the fiber bundle. Locate less important fibers on the outside of the fiber bundle. Shine a flashlight from the lens back to the PG2000 to help identify the fibers.
- c. If the total number of fibers is less than 200 then add additional fibers to the fiber bundle until the total number of fibers is either 100 or 200. These additional fibers should be at least 6 inches long and arranged on the outside of the fiber bundle.

⚠WARNING

Fibers outside the 400 fiber bundle diameter do not provide adequate light output for primary pool/spa underwater lenses or perimeter cable. Outer 200 fibers are intended only for accessory lighting. For primary pool/spa lighting and perimeter cable use only the center 400 fibers. If 600 fibers are installed into the ferrule and all cables are of nearly equal importance and length, mix all of the fibers together in the ferrule assembly. Failure to provide adequate lighting can result in swimming and diving hazards that can cause severe injury or death.

- 2. Select the proper compression nut and grommet for the number of fibers; see Table 2.
- 3. See Table 2 to determine if the ferrule insert is needed in the assembly.
- 4. Slide the compression nut, grommet, ferrule insert (if applicable, smaller diameter pointing out), and then ferrule body onto the fiber bundle, see Figure 7 for proper orientation. Leave about 3 to 4 inches of fiber sticking out past the two posts on the top of the ferrule.

Table 2

| Number of fibers | Compression Nut (check inner dia.) | Grommet (size indicated on back except 400 and 600 grommet) | Ferrule Insert (located on disk tree) |
|------------------|------------------------------------|---|---------------------------------------|
| 100 | Small I.D. | 70 | yes |
| 200 | Small I.D. | 225 | yes |
| 200-300 | Small I.D. | 225 | yes |
| 300-425 | Small I.D. | 325 | yes |
| 425-500 | Small I.D. | 400 (small I.D. cylinder) | no |
| 500-600 | Large I.D. | 600 (large I.D. cylinder) | no |

- 5. Tighten the compression nut until the fibers are securely held by the ferrule assembly.
 - a. **DONOT** use ferrule mounting flanges for leverage when tightening assembly as they may break off. Make sure fibers are not twisted or tangled.
 - b. Pull on the fiber bundle to verify fibers are held securely by ferrule assembly. It may be necessary to apply a few wraps of electrical tape underneath the grommet to ensure a good grip.
- 6. Install the fiber disk onto the ferrule assembly.
 - a. Choose the correct metal fiber disk according to the number of fibers. The maximum fiber capacity is on each disk. See Table 3 for the proper metal fiber disk size.

| FIBER RANGE | NUMBER ON NEW METAL FIBER DISK |
|-------------|--------------------------------|
| 100 only | 100 |
| 200 only | 200 |
| 205-225 | 225 |
| 230-255 | 255 |
| 260-290 | 290 |
| 295-330 | 330 |
| 335-400 | 400 |
| 405-495 | 495 |
| 500-600 | 600 |

⚠CAUTION

This unit is designed for use with new metal fiber disks in the ferrule assembly. Install unit using only new metal fiber disks like those included with this parts kit. Use of original plastic disks with this unit may lead to failure of fiber cable.

(Continued on page 21)

Ferrule Assembly Installation Steps,

as detailed in Sec. VIII A - D.

- Tools and Material Required:**
- ✓ Cable Cutters
 - ✓ Cable Stripper
 - ✓ Crescent Wrench
 - ✓ Hot Knife
 - ✓ Phillips Screwdriver
 - ✓ Cutting Shield
 - ✓ Electrical Tape

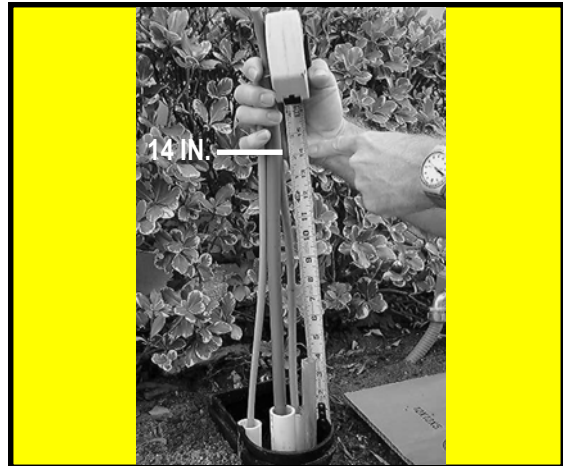

1. Cut all cables 14 in. above Sub-terrain Base.



2. Strip jackets from 0 to 2 in. above the base.

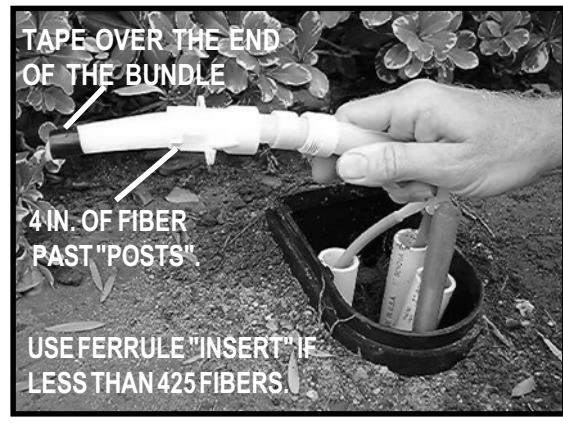

3. Assemble comp. nut, grommet, and ferrule body.



4. Securely tighten the ferrule assembly.



5. Pull on ferrule to check tightness.



6. Select the correct "numbered" fiber disk.



7. Snap disk into "ears".

Ferrule Assembly Installation Steps, continued.



8. Screw on the cutting shield.



9. Hot knife cut, at a 15 deg. blade angle.



10. Inspect the cut, no lines or "puddles".



11. Set PG2000, but do not screw to base.



12. Tip PG2000 back and secure "ears" under thumbscrews.



13. Secure PG2000 to base with 4 screws provided.



14. Carefully install outer body.



15. Secure outer body with two screws.

- b. Slide the fiber disk, tapered end down, over the fiber bundle. Snap the fiber disk into the fiber disk support posts on the ferrule.

⚠ CAUTION

Make sure there is enough slack in the cable(s) to be put in place. There should be about 3-4 in. of slack in the fiber bundle. If not, readjust the ferrule accordingly. This will provide ample fiber for future trimming of bundle required about every 5 years.

C. Cut the fiber, see Pictures on page 20.

1. Place the Cutting Shield onto the ferrule assembly and thread on until it bottoms out.
2. Hold the cable and ferrule assembly so the support posts are at the top and bottom (not on the sides), keeping the cable and fiber bundle as straight as possible.
3. Place the FiberKnife blade against the Cutting Shield guide ring at a 10-15 degree angle starting at the top Support Post.

⚠ IMPORTANT

Press with a light to moderate constant pressure using the cutting shield ring as a guide. **IMPORTANT:** Do not rush - allow 3 – 4 minutes to cut 600 fibers.

DO NOT use too much force - Let the heat of the knife do the cutting.

DO NOT saw, wiggle or rotate the blade back and forth.

On the larger fiber bundles, it may help to rotate the handle side of the blade downward slightly.

- a. Ease up towards the end of the cut to keep the last few fibers from folding over.
4. Remove Cutting Shield and wipe the fiber face with an optic prepad or clean cloth. This removes any residual powder.

⚠ WARNING

Shield may be hot. Exercise caution when removing it. Failure to do so could cause burns.

5. Inspect the cut.
 - a. The cut should be smooth and flat, with no visible lines or surface bubbles. When training and performing your first cuts, use of a small magnifying glass can help see imperfections that may be difficult to see with the naked eye.
 - b. A good professional cut is critical to the performance of the fiber optic system. There are several things which can cause a bad cut:
 - Sawing or wiggling the blade during cutting.
 - Holding the blade at an incorrect angle.
 - Burrs on the edge of the cutting shield.
 - The FiberKnife is not warmed up enough. Allow enough time between cuts for the knife to reheat, and keep it out of the wind while it is heating.
 - The blade needs replacing (about every 15 - 20 cuts. Pack of 3 blades, P/N 21005600).

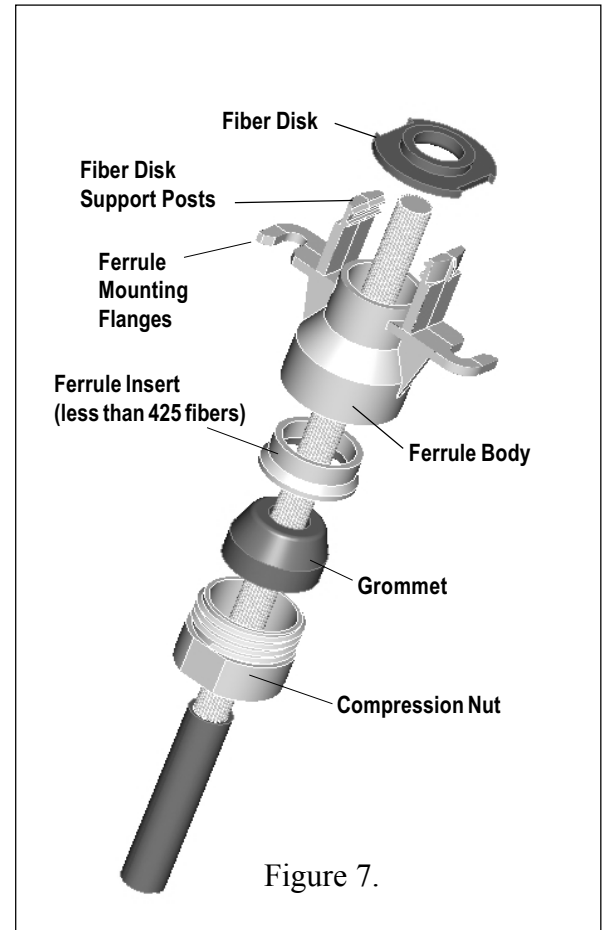

SECTION VIII. Installing the PG2000

A. Preparation.

1. Seal the conduit around the cable with RTV silicone or conduit seal kit #22002000 to prevent water from entering or leaking from the conduit.
2. Remove outer body from PG2000 by removing one black #6 screw on each side at bottom. Carefully lift outer body up and set aside with screws placed inside or in a pocket for safe keeping.
3. Remove bag of screws from back of Sub-terrain mounting base (if used) and put inside outer body or pocket for safe keeping.
4. Holding the PG2000 by the bottom or the two Black posts in front, carefully set it down over the ferrule fiber bundle and electrical conduit. (Do not secure to base or deck at this time.)

B. Connecting the ferrule bundle.

1. Tip PG2000 back and twist lock the ferrule assembly into the optic port (hole) and the retaining screws under the PG2000 light bulb.
3. Be sure that the ferrule "ears" are securely against both screws and tighten the thumbscrews.
 - The ferrule body should be centered in the optic port. The alignment of the ferrule assembly is CRITICAL to the performance of the fiber optic system.

C. Mounting the PG2000 to the Sub-terrain Base.

1. Secure PG2000 to Sub-terrain Base (if used) using the screws provided in the package taped to the Sub-terrain Base and set aside in step A-3.

D. Mounting the PG2000 to a wood or concrete deck.

1. First see Section IV, C., in this manual.
2. Secure PG2000 to the wood deck or into the anchors previously installed in the concrete using the lag screws and washers provided in the PG2000 parts bag.

E. Wiring the PG2000.

⚠WARNING



RISK OF ELECTRICAL SHOCK OR ELECTROCUTION

This PG2000 must be installed by a licensed or certified electrician in accordance with the National Electrical Code and all applicable local codes and ordinances. Improper installation will create an electrical hazard which could result in death or serious injury to pool users, installers, or others, due to electrical shock, and may also cause property damage.

1. For manual operation, operation by a single remotely located toggle switch or automatic control button, (such as Compool® or IntelliTouch®), or for use with optional RF2000 Wireless Control, (P/N 840069). See Figure 8 for proper setting of the toggle switches on bottom of the PG2000.

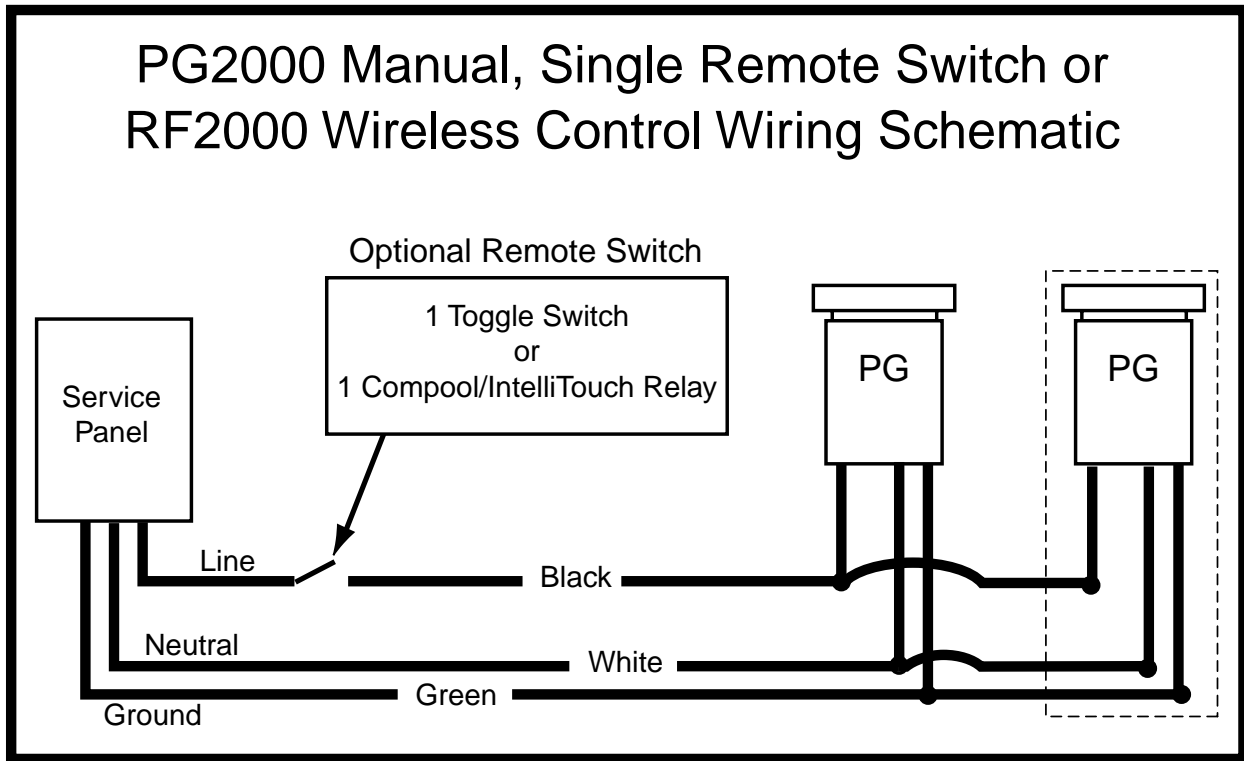

This application requires that only three, minimum #18 gauge, wires be run to the unit (black/white/green). Connect Black supply wire to Black wire in unit, Connect White to White and Green to Green.
NOTE: YELLOW WIRE IS NOT USED IN THIS CASE.

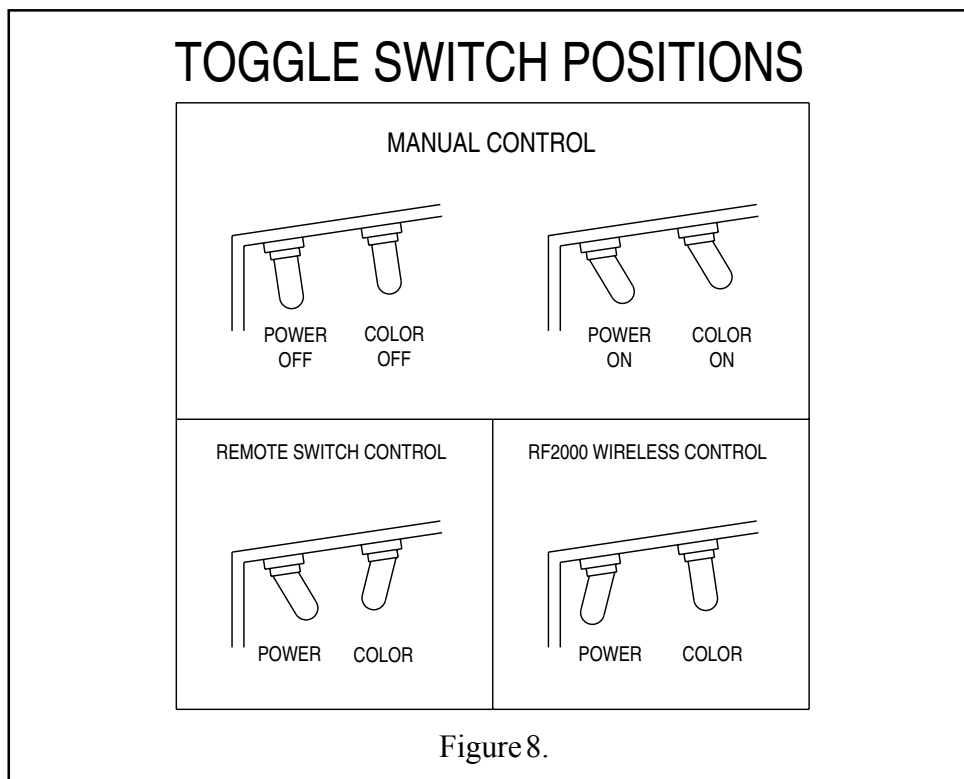

- For operation by two remotely located toggle switch or automatic control buttons, (such as Compool® or IntelliTouch®). See Figure 8 for proper setting of the toggle switches on bottom of the PG2000.

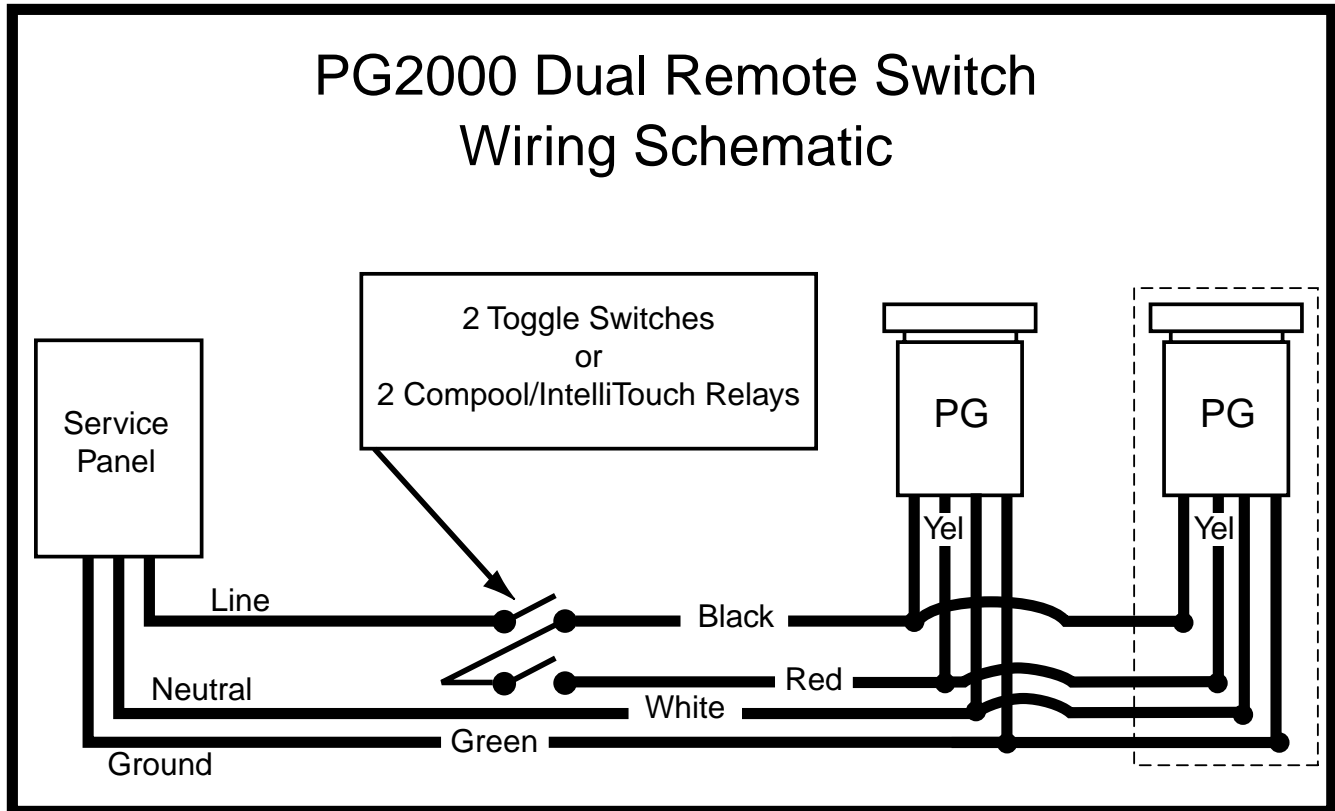

This application requires that four, minimum #18 gauge, wires be run to the unit (black/red/white/green). Connect Black supply wire to Black wire in unit, Connect Red to Yellow, White to White and Green to Green. Connect the Black wire to the Light Bulb power switch or relay and the Yellow/Red wire to the Color Wheel power switch or relay. Provide a jumper wire from the load side of the Light Bulb switch or relay to the supply (line) side of the Color Wheel switch or relay. This will prevent the color wheel from turning when the light bulb is not turned on. For automatic control system such as Compool®, refer to the controller's manual to determine which buttons operate the two relays.

A note about FreedomSynch™ PG2000's (840242) wiring and operation.

The wiring for these units is exactly the same as for all other PG2000s. Units can be connected in parallel or in series. All synchronization is self contained within the unit's electronics, and is locked to the 60 Hz AC power line. If there is more than 100 ft. difference between wire lengths of the first and last PG2000 in a series, increase the wire gauge to reduce line losses that might prevent the synchronization circuitry from operating properly once the colorwheels are turned on simultaneously, it will take about 1½ minutes for the colors to synchronize. Please refer to the Owner's Manual for proper operation of these models.

F. Carefully place outer body back onto the PG2000 and secure with two black #6 screws (previously set aside) at the bottom.

G. Test functionality of unit.

NOTE

When cycling system off, then back on, it may take up to 3-4 minutes before the lamp "restrikes" or comes back on. The lamp must cool down before restriking. All metal halide lamps have this characteristic and this is a normal function of the PG2000.

SECTION IX. Synchronization of *SAm*[®]/*SAL*[®] and *FIBERworks*[®] (Wiring Diagrams)

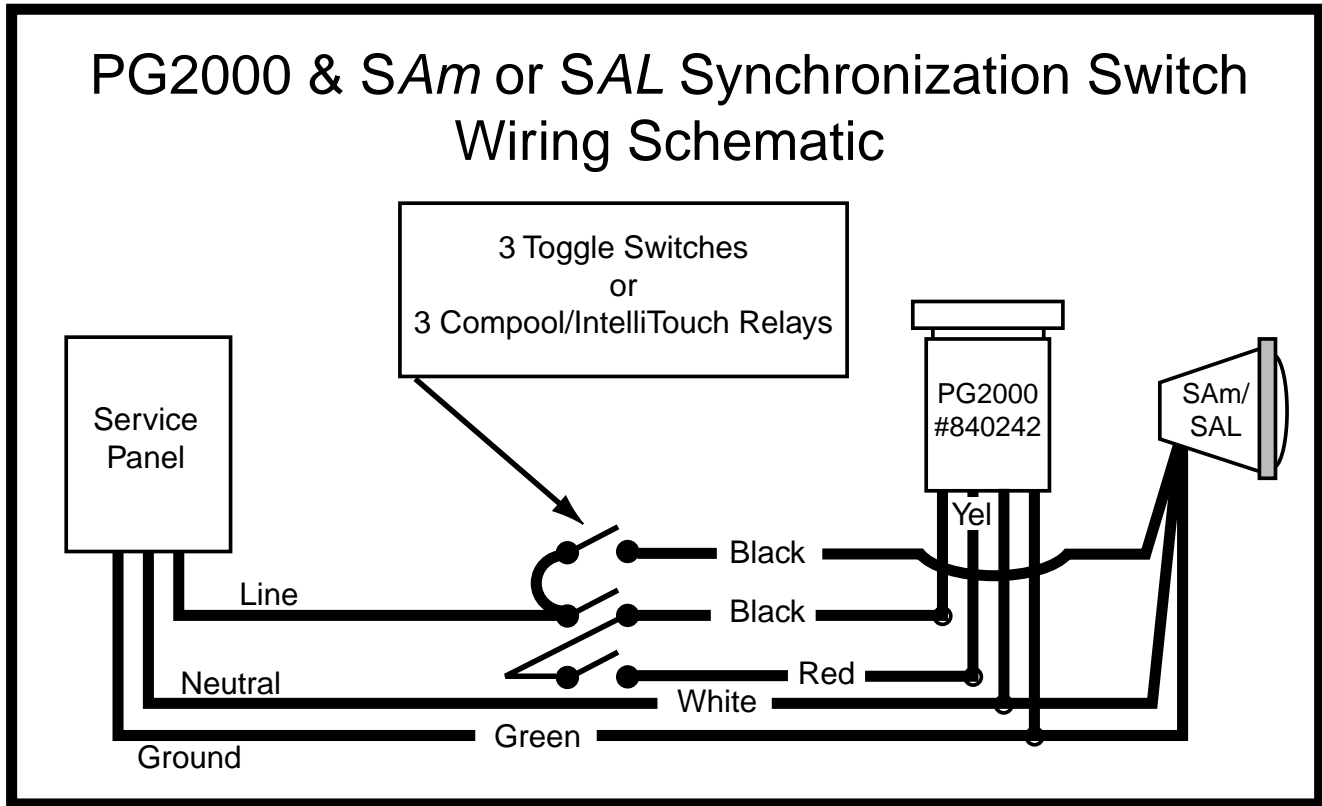

NOTE

There may be slight color variations between the *SAm*[®]/*SAL*[®] and PG2000 depending on the application. These variations are caused by differences in initial light intensity and attenuation of the water and/or reflective surfaces (i.e. pool wall coloring).

In order for instructions to work you must have P/N 840242 – 7 Color, Electronic Synchronized PG2000 (all other part numbers must use visual synchronization method).

A. Compool[®] Programming

1. If you use a Compool system, you can automate the process by programming two identical start and run times for the *SAm*[®] or *SAL*[®] auxiliary channel(s). (i.e., Program 1 - **ON**: 8:00 PM, **Run Time**: 4 Hours; Program 2 - **ON**: 8:00 PM, **Run Time**: 4 Hours.) The two channels for the PG2000 should be programmed to come on only one time. (i.e., Program 1 - **ON**: 8:00 PM, **Run Time**: 4 Hours). Of course, you could also program *SAm*[®], *SAL*[®] or *FIBERworks*[®] to run alone or even out of synchronization if desired.

B. IntelliTouch[®] Programming

If you use an IntelliTouch system, you can automate the process by identifying the applicable circuit as a *SAm*[®], *SAL*[®] or **Color Wheel** (go to MENU/SETUP/ADVANCED/CIRCUIT FUNCTIONS). Once this is done, you will have the option in the Programming to set these circuits to "SMART START". All circuits set to "SMART START" and programmed to come on at the same time will automatically synchronize.

(continued on next page)

C. PG2000 Synchronization Procedures with *SAm/SAL* light

Listed below are the procedures to follow if you have a *SAm/SAL* underwater color light installed in your pool or spa and wish to synchronize your fiber optics with *SAm/SAL*.

D. Synchronization Start Conditions

1. *SAm/SAL* is ON and colorwheel is stopped on ANY color (including white).
2. **PG2000** power is ON and the colorwheel is OFF.

E. Synchronization Procedure

1. Simultaneously toggle *SAm/SAL* OFF/ON and turn the **PG2000** colorwheel ON.
2. Allow about 1½ minutes for colors to synchronize. *Enjoy!*
3. To stop both lights on the same color, simultaneously toggle *SAm/SAL* OFF/ON and turn the **PG2000** colorwheel OFF.

F. Visual Synchronization Method (for use with P/N 840241 only)

1. Turn *SAm/SAL* ON, colorwheel is stopped on ANY color (including white).
2. Turn **PG2000** ON and colorwheel ON.
3. When **PG2000** transitions between purple and magenta toggle *SAm/SAL* OFF/ON.
4. To stop both lights on the same color, simultaneously toggle *SAm/SAL* off and on while turning the **PG2000** colorwheel off.

SECTION X. Technical Data

A. Replacement Parts

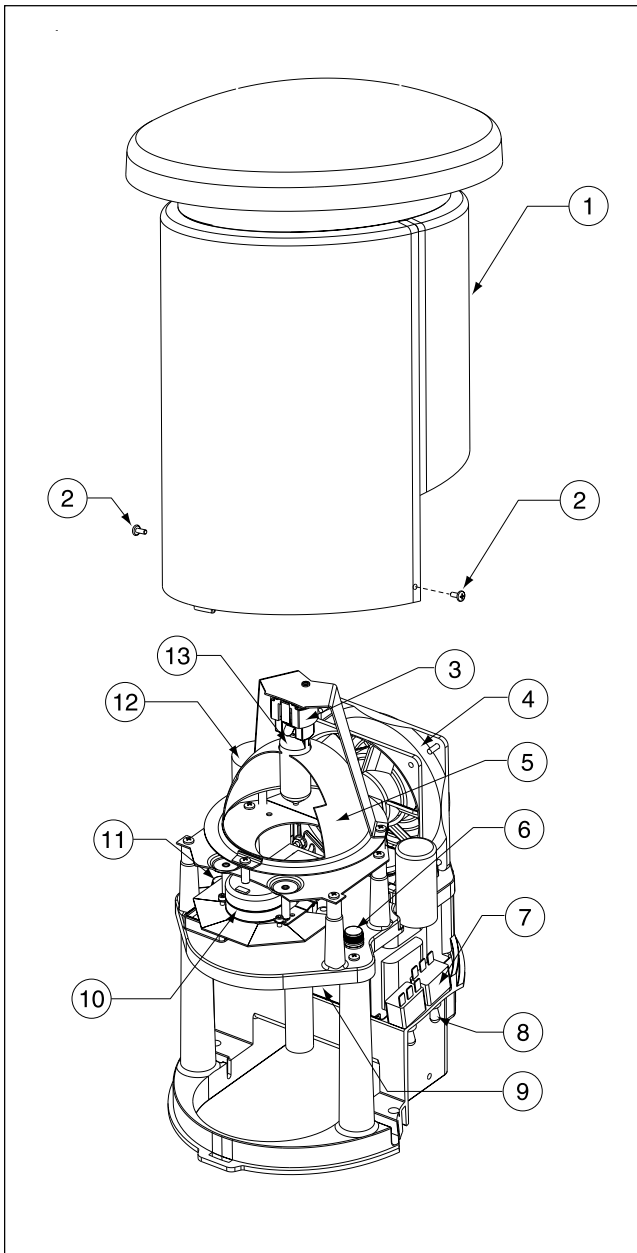

| Item No. | Part No. | Description |
|------------------|----------|---------------------------------------|
| 1 | 840321 | Body assy., w/mounting screws |
| 2 | 23506100 | Screw, #6 x 3/8 in., Pph mach., black |
| 3 | 840323 | Socket |
| 4 | 840322 | Fan |
| 5 | 840188 | Reflector |
| 6 | 23505600 | Fuse, 3 amp |
| 7 | 840219 | Switch, toggle |
| 8 | 840220 | Boot, toggle |
| 9 | 840233 | Ferrule nut, #10-24, knurled |
| 10 | 840324 | Colorwheel assy. |
| 11 | 840236 | Fuse, 1/2 amp |
| 12 | 840304 | Capacitor |
| 13 | 840211 | Bulb, 150w, MH |
| NOT SHOWN | | |
| | 840325 | Ferrule assy. |

SAVE THESE INSTRUCTIONS.

PG2000® Conduit Template

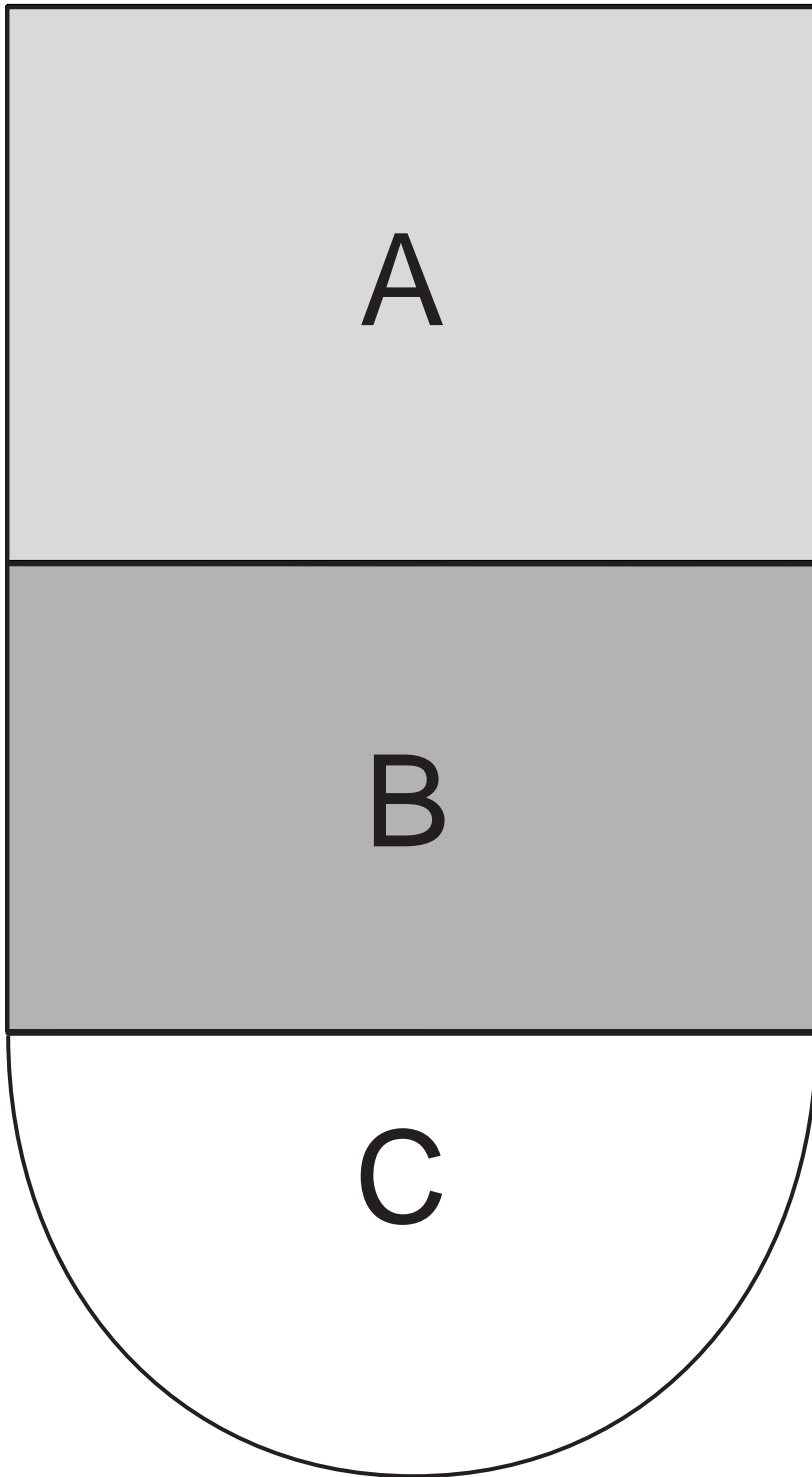

Electrical C
 AmerGlow 100, 170, 225, 325 B,C
 AmerGlow 12, 30, 50, 70 A, B, C

Pentair Water Pool and Spa, Inc.

1620 Hawkins Ave., Sanford, NC 27330 • (919) 566-8000
 10951 West Los Angeles Ave., Moorpark, CA 93021 • (805) 523-2400



© 2005 Pentair Water Pool and Spa, Inc. All rights reserved.

This document is subject to change without notice.

Trademarks and Disclaimers. The *Pentair Water Pool and Spa logo* is a trademark of Pentair Water Pool and Spa, Inc. PG2000, FIBERworks, SAM, SAL, Amerlite, AquaLight, HiLite, Compool, and IntelliTouch are registered trademarks of Pentair Water Pool and Spa, Inc. Other trademarks and trade names may be used in this document to refer to either the entities claiming the marks and names of their products. Pentair Water Pool and Spa, Inc. disclaims any proprietary interest in trademarks and trade names other than its own.