

# INTEX® OWNER'S MANUAL

168  
PO

## Quick-Fill™ Electric Air Pump

Model AP638; 6C Cell Size Batteries; 4.5 V

READ AND FOLLOW ALL INSTRUCTIONS BEFORE USING THIS PRODUCT

### ⚠ WARNING

- Adult use only.
- Do not drop unit into water or expose unit to rain or water.
- Do not direct air stream at face or body.
- Do not obstruct vent holes or open source.
- Do not insert objects into the inflation or deflation connector.
- Do not operate air pump for more than 10 minutes at a time. Let pump cool at least 5 minutes between use.
- This appliance is not intended for use by persons (including children) with reduced physical, sensory or mental capabilities, or lack of experience and knowledge, unless they have been given supervision or instruction concerning use of the appliance by a person responsible for their safety.
- Children should be supervised to ensure that they do not play with the appliance.

FOLLOW THESE RULES AND ALL INSTRUCTIONS TO AVOID PROPERTY DAMAGE, ELECTRIC SHOCK, BURNS OR OTHER INJURY.

### NAMES OF PARTS

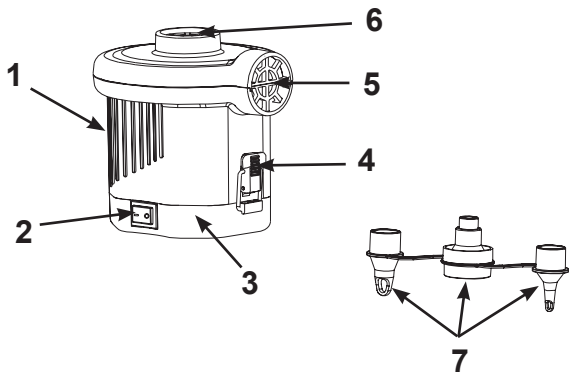

#### PARTS DESCRIPTION:

1. PUMP
2. SWITCH
3. BATTERY COMPARTMENT COVER
4. TRIGGER AND CLIP
5. INFLATION CONNECTOR
6. DEFLATION CONNECTOR
7. NOZZLES

NOTE: Drawings for illustration purpose only. Actual product may vary. Not to scale.

### INSTRUCTIONS

#### General

- For maximum power use alkaline batteries. Remove batteries from equipment which is not to be used for an extended period of time.
- Do not mix old and new batteries. Do not mix alkaline, standard (Carbon - Zinc), or rechargeable (Nickel - Cadmium) batteries.
- Remove used batteries promptly.
- Do not dispose of airpump and its batteries in a fire. Check your local regulations for proper disposal instructions.
- Keep away from heat or direct sunlight.
- Return pump and nozzles to package when not in use.
- No specific air pump maintenance is required.
- Always purchase the correct size and grade of battery most suitable for the intended use.
- Replace all batteries of a set at the same time.
- Clean the battery contacts and also those of the device prior to battery installation.
- Ensure batteries are installed correctly with regard to polarity (+ and -).

## SAVE THESE INSTRUCTIONS

### INSTRUCTIONS

168  
PO

#### INSTALL OR REPLACE BATTERIES

1. Open battery compartment cover. See Fig (1).
2. Insert 6-"C" alkaline batteries (**NOT INCLUDED**) as shown on the drawings inside the battery compartment. See Fig (2).
3. Replace battery compartment cover. See Fig (3).

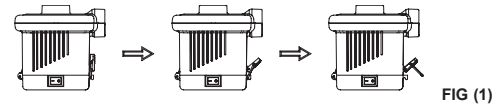

FIG (1)



FIG (2)

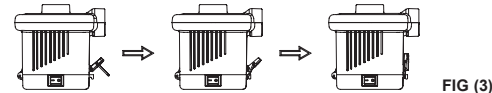

FIG (3)

#### INFLATION

1. Attach nozzle to the inflation connector if necessary and hold pump against inflation valve on item to be inflated. See Fig (4).  
**NOTE:** On large items like inflatable boats and large air mattresses, the pump will fit directly into the inflation valves and provide faster inflation times. Use the appropriate nozzle on small inflation valves as on small air mattresses, etc.
2. SWITCH ON: Press "I"; SWITCH OFF: Press "O". See Fig (5).

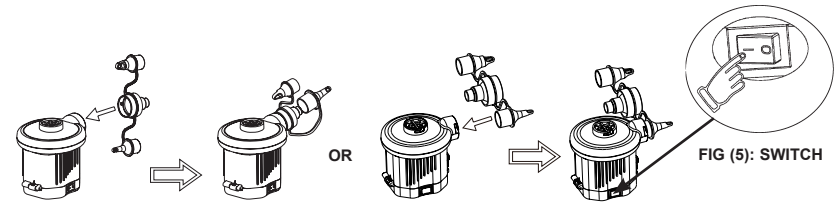

FIG (4): ATTACH NOZZLE

#### DEFLATION

1. Attach nozzle to the deflation connector if necessary and hold pump against inflation valve on item to be deflated. See Fig (6).  
**NOTE:** On large items like inflatable boats and large air mattresses, the pump will fit directly into the inflation valves and provide faster deflation times. Use the appropriate nozzle on small inflation valves as on small air mattresses, etc.
2. SWITCH ON: Press "I"; SWITCH OFF: Press "O". See Fig (5).

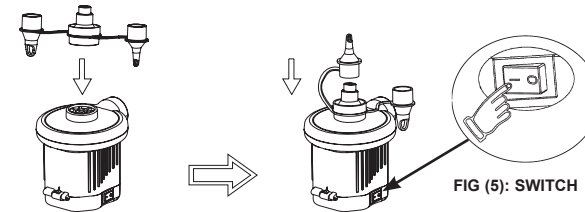

FIG (6): ATTACH NOZZLE

©2014 Intex Marketing Ltd. - Intex Development Co. Ltd. - Intex Trading Ltd. - Intex Recreation Corp.  
All rights reserved/Tous droits réservés/Todos los derechos reservados/Alle Rechte vorbehalten.  
Made in China/Fabriqué en Chine/Hecho en China/Hergestellt in China.  
®™ Trademarks used in some countries of the world under license from®™ Marques utilisées dans certains pays sous licence de/Marcas registradas utilizadas en algunos países del mundo bajo licencia de/Warenzeichen verwendet in einigen Ländern der Welt in Lizenz von/Intex Marketing Ltd. to/à/an Intex Trading Ltd., Intex Development Co. Ltd., G.P.O Box 28829, Hong Kong & Intex Recreation Corp., P.O. Box 1440, Long Beach, CA 90801 • Distributed in the European Union by/Distribué dans l'Union Européenne par/Distribuido en la Unión Europea por/Vertrieb in der Europäischen Union durch/Intex Trading B.V., Venneveld 9, 4705 RR Roosendaal - The Netherlands  
Consumer Service 1-800-234-8839  
www.intexcorp.com



## SAVE THESE INSTRUCTIONS