

Swimming Pool Heat Pump

INSTALLATION AND USER MANUAL



Content

I.	Application	2
II.	Features.....	2
III.	Technical Parameter	3
IV.	Dimension.....	4
V.	Installation instruction	5
VI.	Operation instruction.....	9
VII.	Testing.....	12
VIII.	Precautions	12
IX.	Maintenance.....	14
X.	Trouble shooting for common faults	15

Thank you for choosing our heat pump. Please read this instruction manual carefully and operate strictly according to the user manual before starting the heat pump, otherwise the heat pump may be damaged or cause you unnecessary harm.

This appliance is not intended for use by persons (including children) with reduced physical, sensory or mental capabilities, or lack of experience and knowledge, unless they have been given supervision or instruction concerning use of the appliance by a person responsible for their safety.

Special Attention:

- A. This product is only for swimming pool water heating & cooling applications and can't be used for the heating for any other liquid materials.
- B. The inlet and outlet water nozzles can't bear the weight of external pipes.
- C. The main power switch should be out of the reach of children.
- D. Make sure the power is switched off before opening the case.

NOTE:

- A. The swimming pool heat pump must be installed by a qualified electrician.
- B. To maximize your swimming comfort, set proper heating temperature.
- C. Don't put obstacles near the air inlet and outlet of the heat pump.
- D. This heat pump has power-off memory function.
- E. When the ambient temperature is below 0 degree, make sure to switch off the main power, and drain off the water from heat exchanger.
- F. Never place your hand or any other object in the air inlet or outlet of the heat pump.
- G. If any abnormal circumstances discovered, ex: abnormal noise, smells, smokes and leakage of electricity, switch the main power off immediately and contact your local dealer/installer. Do not try to repair the heat pump yourself.

I. Application

- 1- Set swimming pool water temp efficiently and economically to provide you comfort and pleasure.
- 2- User may choose the model technical parameter according to professional guide, this series of swimming pool heater has been optimized in factory (refer to technical parameter table).

II. Features

- 1- Sensitive and accurate temp control and water temp display.
- 2- High pressure and low pressure protection.
- 3- Exceeding low temp auto stop protection.
- 4- Temp control compulsory defrosting.
- 5- International brand compressor.
- 6- High efficient titanium heat exchanger.
- 7- Easy installation and operation.

III. Technical Parameter

Model	ECO550	ECO900
Applied pool volume (gallons)	≤14000	≤28000
Operating air temperature (°F)	32~109	
Performance Condition: Air 80°F/ Water 80°F/ Humidity 80%		
Heating capacity (Btu)	50,000	90,000
Heating capacity (Btu) in silence mode	40,000	72,000
C.O.P	10.6~5.98	13.6~6.0
Performance Condition: Air 80°F/ Water 80°F/ Humidity 63%		
Heating capacity (Btu)	47,500	85,000
Heating capacity (Btu) in silence mode	37,200	68,000
C.O.P	9.7~5.5	12.3~5.7
Performance Condition: Air 50°F/ Water 80°F/ Humidity 63%		
Heating capacity (Btu)	23,000	43,000
C.O.P	5.1~4.15	5.5~4.3
Rated input power (kW) at air 80°F	0.46~2.53	0.54~4.39
Rated input current (A) at air 80°F	2.00~11.0	2.34~19.1
Power supply	208~230V/1 Ph/60Hz	
Advised water flux (L/min)	83~117	125~158
Sound pressure 10'FT dB(A)	34.9~46.0	34.9~46.8
Heat exchanger	Titanium in PVC	
Casing	ABS casing	
Air discha Air discharge rge	Horizontal	
Water pipe in-out Spec (mm)	48	
Net Dimension LxWxH (mm)	961x340x658	1092x420x958
Net Weight (lbs.)	114	187

Notice:

1. This product works well under water temp 80°F ~+104°F, air temp 32°F ~+109°F, efficiency will not be guaranteed out of this range. Please take into consideration that the pool heater performance and parameters are different under various conditions.
2. Related parameters are subject to adjustment periodically for technical improvement without further notice. For details please refer to nameplate.

IV. Dimension

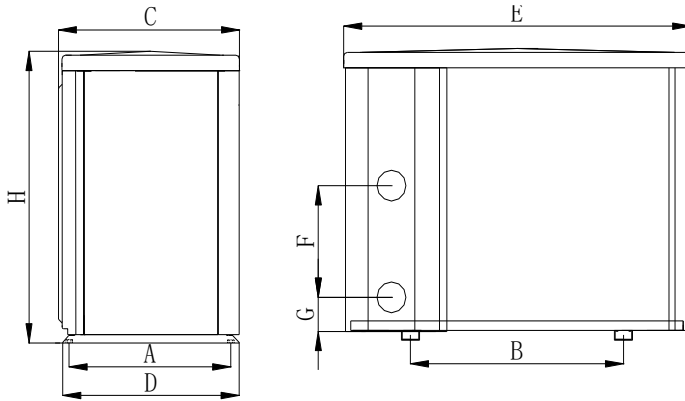

Size(mm) Name Model	A	B	C	D	E	F	G	H
ECO550	315	590	312	340	961	330	74	658
ECO900	395	720	392	420	1092	620	74	958

※ Above data is subject to modification without notice.

Note:

The picture above is the specification diagram of the pool heater, for technician's installation and layout reference only. The product is subject to adjustment periodically for improvement without further notice.

V. Installation instruction

1, Drawing for water pipes connection.

Note: The swimming pool heater must be grounded.

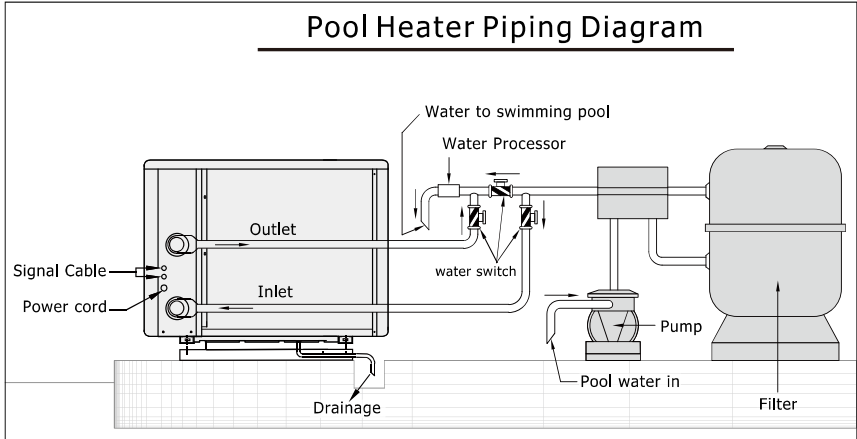

(Notice: The drawing demonstration and layout of the pipes is only for reference.)

2, Electric Wiring Diagram

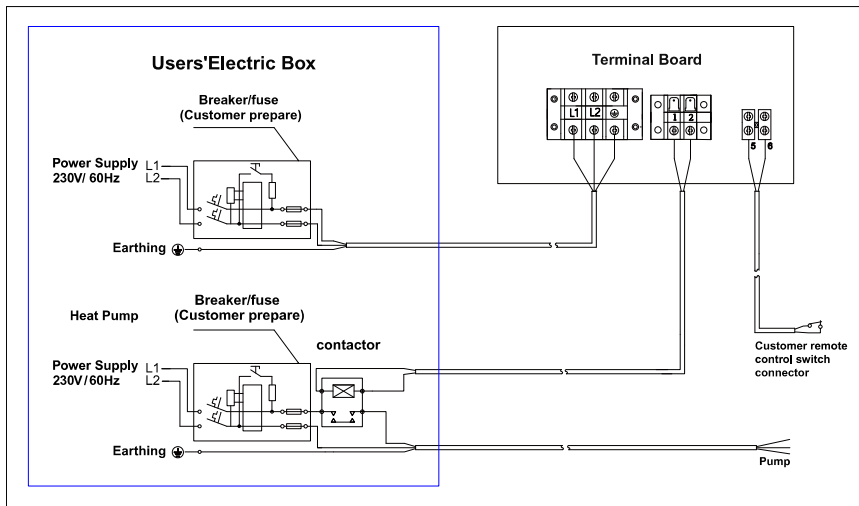

Note: 1)  Must be hard wired, no plug allowed.

2) The swimming pool heater must be grounded.

- 3) **WARNING:** Before obtaining access to terminals, all supply circuits must be disconnected.
- 4) 5-6 terminal: Customer remote control switch connector, to reach automation control through 2-wire dry contact connection, and only control the unit On/Off.

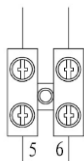

Jumper is installed by default, if loosen or disconnection "OFF" will display.

Options for protecting devices and cable specification

MODEL		ECO550	ECO900
Breaker	Rated Current A	15.5	26
	Rated Residual Action Current mA	30	30
Fuse	A	15.5	26
Power Cord	(AWG)	3x13	3x10
Signal cable	(AWG)	3x20	3x20

※ Above data is subject to modification without notice.

Note: The above data is adapted to power cord ≤ 10 m. If power cord is > 10 m, wire diameter must be increased. The signal cable can be extended to 50 m at most.

Installation and Requirements

The swimming pool heater must be installed by a pool professional. End users are not qualified to install the heater. Damage may occur to the heater or threaten the safety of the user.

A. Installation

- 1) The swimming pool heater should be installed in a location with good ventilation;
- 2) The frame must be fixed by bolts (M10) to concrete foundation or brackets. The concrete foundation must be solid and fastened; the

- bracket must be strong and antirust treated;
- 3) Don't stack substances that will block air flow near inlet or outlet area, and no barrier within 20in behind the main heater, or the efficiency of the heater will be reduced or even halted;
 - 4) The heater needs an appended pump (Supplied by the user). The recommended pump specification-flux: refer to Technical Parameter, Max. lift $\geq 10\text{m}$;
 - 5) When the heater is running, there will be condensation water discharged from the bottom. Please hold the drainage nozzle (accessory) into the hole and attach it well, then connect a pipe to drain the condensation water out.

B. Wiring

- 1) Connect to appropriate power supply; the voltage should comply with the rated voltage of the products.
- 2) Heater must be grounded.
- 3) Wiring must be handled by a professional technician according to the circuit diagram.
- 4) Set leakage protector according to the local code for wiring (leakage operating current $\leq 30\text{mA}$).
- 5) The layout of power cable and signal cable should be orderly and not interfere with each other.
- 6) The appliance shall be installed in accordance with national wiring regulations.

C. Switch on after finishing all wiring construction and re-checking.

Pay attention to the following points:



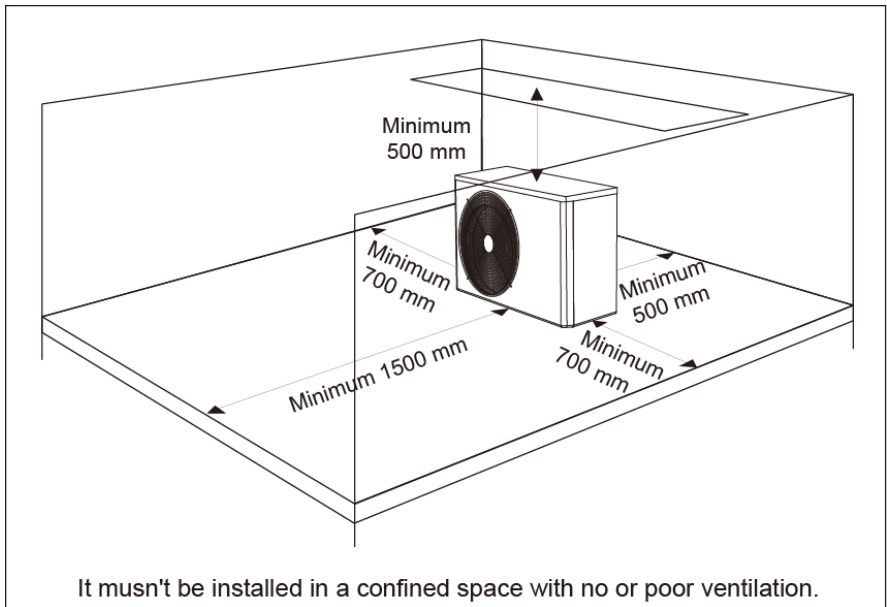

1. The heat pump must be installed **OUTSIDE** in a well ventilated area to avoid air recirculation, or in a place with adequate room for both installation and maintenance. Please refer to the following illustration:

A minimum of 500mm of clearance from walls, shrubbery, equipment, etc. is required around the entire pump circumference. This allows for ample air intake. No less than 1000mm clearance on the air outlet is required to prevent recirculation of air. We recommend to not place the unit underneath eaves, decks, or porches, as this causes recirculation of discharged air, or the efficiency of the heater will be reduced or even stopped.

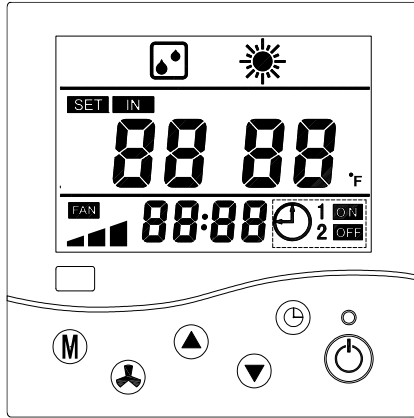

VI. Operation instruction



Symbol	Designation	Operation
	Power ON/OFF	Press to power on or off the heat pump
	Up/ Down	Press to set desired water temperature
	Fan	Press to select Silence mode
	Heating mode	Only heating is available
	Timer	Timer set up

Note:

- ① You may set the desired water temperature from 65 to 104°F.
- ② Only the inlet water temperature is displayed, normally the outlet water temperature will be 2-4°F higher.
- ③ After you turn on the heat pump, the fan will start to run in 3 minutes. In another 30 seconds, the compressor will start to run.

1. Status on the display



2. Time setting

① Press for 5 seconds to enter time setting. 88:88 is flashing on the display

② Press and to adjust the time (fast adjusting by continuous pressing). Then, press to confirm and exit.

③ In the time setting mode, if no operation for 30 seconds, the previous pressing will be lost and exit automatically.

3. Timer on and off

① Press the for 10 seconds to enter the timer setting. The “ON” will be flashing to enter the Timer ON setting. Press the and to adjust Timer ON time. You can choose Timer on (Display: ON), or Repeat Timer ON (display: 1 ON) by pressing . Then press to confirm.

② When the “ON” stops flashing, and “OFF” is flashing, you enter the Timer OFF mode. Press the and to adjust Timer OFF time. You can choose Timer OFF (Display: OFF), or Repeat Timer OFF



(display: 2 OFF) by pressing . Then press  to confirm.

③ After entering the Time ON/OFF setting, press  directly without adjusting the time to cancel the relevant Timer setting.



④ Exit automatically if no operation for 30 seconds in the Timer ON/OFF mode,

4. Silence mode

① The Smart mode as default will be activated when the machine is tuned on. And the display shows “”.

② When machine is on, press “” button to enter the Silence mode. “” will be light. Press “” again to exit.

5. Compulsory defrost

① When the machine is on heating and the compressor is working continuously for 10 minutes, press both “” and “” buttons for 5 seconds to start compulsory defrost. (Note: the break between compulsory defrost needs to be more than 30 minutes.)

② The symbol of defrost is twinkling when machine is compulsory or auto defrost.

③ The period and ending of compulsory defrost is the same as auto defrost.

VII. Testing

1. Inspection before use

- A. Check installation of the entire heater and pipe connections according to the pipe connecting drawing;
- B. Check the electric wiring according to the electric wiring diagram; and grounding connection;
- C. Make sure that the main heater power switch is off;
- D. Check the temperature setting;
- E. Check the air inlet and outlet.

2. Trial

- A. The user must Start the water pump before the heat pump, and turn off the heat pump before the water pump, or the heat pump will be damaged;
- B. The user should start the water pump, and check for any leakage of water; Power on and press the ON/OFF bottom of the heat pump, and set suitable temperature in the thermostat.
- C. In order to protect the pool heat pump, the heater is equipped with a time lag starting function, when starting the heater; the blower will run 1 minute earlier than the compressor;
- D. After the pool heat pump starts up, check for any abnormal noise from the heater.

VIII. Precautions

1. Attention

- A. Set proper temperature in order to get comfortable water temperature; to avoid overheating or overcooling;
- B. Please don't stack substances that can block air flow near inlet or outlet area, or the efficiency of the heater will be reduced or even stopped;
- C. Please don't put hands into outlet of the swimming pool heater,

- and don't remove the screen of the fan at any time;
- D. If there are abnormal conditions such as noise, smell, smoke and electrical leakage, please switch off the machine immediately and contact the local dealer. Don't try to repair it yourself;
 - E. Don't use or stock combustible gas or liquid such as thinners, paint and fuel to avoid fire;
 - F. In order to optimize the heating effect, please install heat preservation insulation on pipes between swimming pool and the heater. During running period of the swimming pool heater, please use a recommended cover on the swimming pool;
 - G. Connecting pipes of the swimming pool and the heater should be $\leq 10\text{m}$, or the heating effect of the heater cannot be ensured;

2. Safety

- A. Please keep the main power supply switch far away from the children;
- B. When a power cut happens during running, and later the power is restored, the heater will start up automatically. So please switch off the power supply when there is a power cut, and reset temp when power is restored;
- C. Please switch off the main power supply in lightning and storm weather to prevent from machine damage that caused by lightning;
- D. If the machine is stopped for a long time, please cut off the power supply and drain water clear of the machine by opening the tap of inlet pipe.

IX. Maintenance

WARNING: DANGER OF ELECTRIC SHOCK

1. “Cut off” power supply of the heater before cleaning, examination and repairing
2. Do not touch the electronic components until the LED indication lights on PCB is off/ turn off.

- A. In winter season when you don't swim:
1. Cut off power supply to prevent any heater damage
 2. Drain water clear of the heater.
 3. Cover the heater body when not in use.

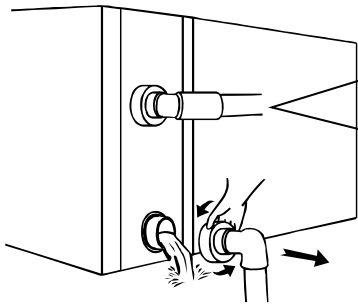

Important:

Unscrew the water nozzle of inlet pipe to let the water flow out.

When the water in machine freezes in winter season, the titanium heat exchanger may be damaged.

- B. Please clean the heater with household detergents or clean water, NEVER use gasoline, thinners or any similar fuel.
- C. Check bolts, cables and connections regularly.

X. Trouble shooting for common faults

Failure	Reason	Solution
Swimming pool heat pump does not run	No power	Wait until the power recovers.
	Power switch is off	Switch on the power.
	Fuse burned	Check to change the fuse.
	The breaker is off	Check to turn on the breaker.
Running but not heating	Air inlet blocked	Remove the obstacles.
	Air outlet blocked	Remove the obstacles.
	3 minutes protection	Wait patiently.
	Set temp too low	Set proper heating temperature.
If the above solution doesn't work, please contact your dealer. Don't try to repair the heater yourself.		

Failure code

NO.	DISPLAY	NOT FAILURE DESCRIPTION
1	E3	No water protection
2	E5	Power supply exceeds operation range
3	E6	Excessive temp difference between inlet and outlet water (Insufficient water flow protection)
4	Eb	Ambient temperature too high or too low protection
5	Ed	Anti-freezing reminder
NO.	DISPLAY	FAILURE DESCRIPTION
1	E1	High pressure protection
2	E2	Low pressure protection
3	E4	Phases lack protection (three phase model only)
4	E7	Water outlet temp too high or too low protection
5	E8	High exhaust temp protection
6	EA	Evaporator overheat protection (only at cooling mode)
7	P0	Controller communication failure
8	P1	Water inlet temp sensor failure
9	P2	Water outlet temp sensor failure
10	P3	Gas exhaust temp sensor failure
11	P4	Heating (Evaporator) coil pipe temp sensor
12	P5	Gas return temp sensor failure
13	P6	Cooling (Titanium heat exchanger) coil pipe temp sensor
14	P7	Ambient temp sensor failure
15	P8	Cooling plate sensor failure
16	P9	Current sensor failure
17	PA	Restart memory failure
18	F1	Compressor drive module failure
19	F2	PFC module failure
20	F3	Compressor start failure
21	F4	Compressor running failure
22	F5	Inverter board over current protection
23	F6	Inverter board overheat protection
24	F7	Current protection
25	F8	Cooling plate overheat protection
26	F9	Fan motor failure
27	Fb	Capacitor no charging protection
28	FA	PFC module over current protection

For Replacement Parts or Technical Assistance, Call 815-675-7000 or
email customersupport@intermatic.com



Version : F51IN

158--02558