

*HeatMaster*TM

by HAYWARD®

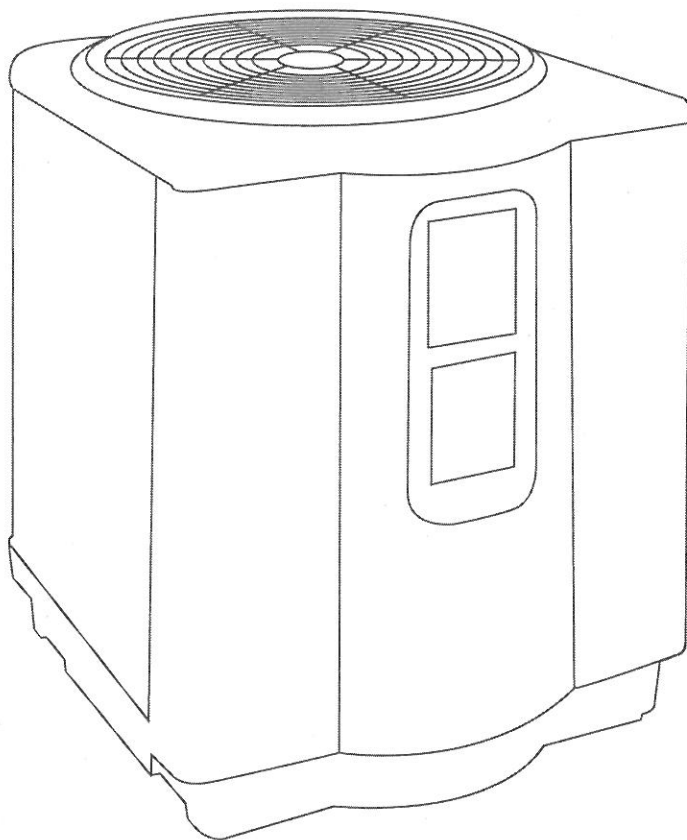

OWNER'S Manual

Table of contents

Introduction	2
General Safety Instructions	4
Installation Instructions	
Location	6
Water piping	7
Electrical	7
Bonding	8
Bonding and plumbing step-by-step instructions	8
Using an External Controller	10
Electrical Connections	11
Wiring Diagram	12
Service Analyzer Control	13
Operation	14
Caring for your Pool Heater	15
Initial Startup	16
Meaning of Display Codes	17
Troubleshooting	18
Requesting Assistance or Service	20
Maintenance	21
Winterizing	21
Pool Heat Pump Warranty	22

Thank you for buying a HEAT MASTER pool heat pump.

The HEAT MASTER pool heat pump is a self-contained unit designed specifically for pool heating. Each component has been selected with care to achieve a high-quality product in an effort to exceed all industry standards.

All HEAT MASTER pool heat pumps* have a Scroll compressor, an electronic board with service analyzer, a titanium heat exchanger tube warranted for 10 years against corrosion and a UV-resistant plastic cabinet that eliminates all maintenance for life. All components are of superior quality, which presents you with an effective, state-of-the-art technology heat pump.

In general, compared to other types of pool heaters, such as gas or oil-fired, the HEAT MASTER pool heat pump has a lower heating capacity on a BTU/hr basis. Therefore, it needs to operate for a longer time to accomplish the desired results. Occasionally, it may be necessary to run the heat pump for up to 24 hours per day. However, this should not be of concern to the owner because the heater is designed to operate continuously. What's more, despite continuous operation, it will still heat the pool far more economically than other types of heaters.

As with all pool heaters, you are advised to use a pool cover at night and when the pool is not in use. The pool cover should be used if night temperatures are 15°F less than desired pool temperature. This will keep evaporation, the greatest source of heat loss, to a minimum, thus greatly reducing the overall pool heating costs. During warmer weather, the pool cover may not be required.

* Except the HML50T model that has a rotative compressor and a 5-year warranty against corrosion on the titanium heat exchanger.

Please read carefully

Record your model's information

Please complete and mail in the ownership registration card provided with this guide. The return address is displayed on the front of your registration card. Simply mail it as you would a postcard. The card helps us notify you about any new information about your heater.

Whenever you call to request service for your heater, you must know your complete model and serial numbers. You can find this information on the plate located at the base of your heater.

Please also record the purchase date of your device and your dealer's name, address, and telephone number.

Model Number _____

Serial Number _____

Purchase Date _____

Dealer Name _____

Dealer Address _____

Dealer Phone _____

Keep this book and the sales slip together in a safe place for future reference.

Service can now be obtained by calling these phone numbers.

CANADA: 1 888 238-7665

USA: 1 908 355-7995

General Safety Instructions

We care for our customers

We have provided important safety messages in this manual and on your heater. Always read and obey all safety messages.

IMPORTANT

 The IMPORTANT sign calls attention to a note that provides important information or information essential to the completion of a task.

CAUTION

 The CAUTION sign denotes a hazard. It calls attention to an operating procedure, practice, or the like, which, if not correctly performed or adhered to, could result in material damage, particularly to the product, up to the destruction of part or all of the product.

WARNING

 The WARNING sign denotes a hazard. It calls attention to a procedure, practice, or the like, which, if not correctly performed or adhered to, could result in personal injury or injury to a third party. These signs are rare, but are extremely important.

CAUTION

! All electrical connections must be done by a qualified electrician and according to the local electrical codes. Always cut off the unit's main power whenever the access panel is open or removed. Always install the machine outdoors (unless otherwise approved by the manufacturer), while respecting the minimal clearances needed for proper operation and heating.

CAUTION

! Proper pool chemistry is vital to the life of your heater. Pay particular attention to the total alkalinity and TDS. It is highly recommended that you have your pool chemistry checked often by an independent pool store.

Water quality standards that must be strictly observed

Description	Normal Range	Verification
pH level	7.4 to 7.8	Once/week
Chlorine concentration	1.0 to 3.0 ppm	Once/2-3 days
Total alkalinity	80 to 100 ppm	Once/2-3 weeks
Total dissolved solids (TDS)	Below 1600 ppm (fresh water)	Once/month
	Below 3000 ppm (salt water)	Once/month
Calcium hardness	200 to 300 ppm	Once/month

Installation Instructions

Location

The placement of the pool heater is very important in keeping installation costs to a minimum while providing for maximum efficiency of operation, as well as allowing adequate access for service and maintenance.

The HEAT MASTER pool heat pump is designed for outdoor installation and should not be installed in a fully enclosed area, such as a shed, garage, etc. Recirculation of cold discharged air back into the evaporator coil will greatly reduce unit heating capacity and efficiency.

The unit should be located as close as practical to the existing pool pump and filter to minimize water piping. However, do not forget to provide a 24" clearance at the very least all around your heat pump. The use of 90 degree bends and short radius elbows in the water piping should be kept to a minimum.

Mount the unit on a sturdy base, preferably a concrete slab or a set of blocks. The base should be completely isolated from the building foundation wall to prevent the possibility of sound or vibration transmission into the building. The size of the base should not be less than 36" x 36" (92 cm x 92 cm).

? IMPORTANT

All HEAT MASTER pool heat pump models feature patented, ultrasilent ventilation systems. Air is pulled through the evaporator coil and discharged through the top grille. A minimum clearance of 48 inches should be allowed above the unit for unrestricted air discharge. The unit must not be installed under a porch. Any side of the unit should be located at least 24 inches from a wall or from any other obstruction for unrestricted air intake and service access.

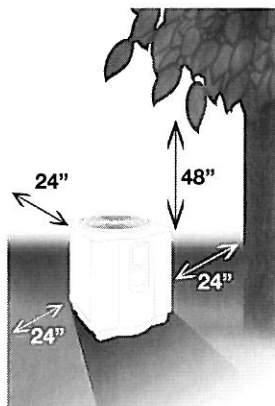

Water piping

IMPORTANT

The piping sequence is as follows: pool pump > filter > heater > pool. Automated chlorine distribution systems, if used, must be placed downstream of the heater to minimize harm to the pool equipment. Use rigid PVC piping if possible (SCH40 or SCH80). All joints should be glued with PVC glue. When the piping installation is complete, operate the pool pump and check the system for leaks. Then, check the filter pressure gauge to verify that there isn't any indication of excessive pump head pressure.

You can also make the connections using high-pressure flexible hose, but make sure the hose can withstand high pressure. The installation of a bypass is not necessary unless the water flow exceeds 80 GPM.

Note: Certain installations have valves which isolate the heat pump from the water circuit. If the heat exchanger is deprived of water circulation for several days, high chlorine gas could cause excessive corrosion. If the disconnect switch is turned off, be sure that the pool water is allowed to circulate through the unit, or is drained out of it.

Electrical

CAUTION

The wiring of your HEAT MASTER pool heat pump should be performed by a qualified electrician in accordance with local requirements.

A properly-sized breaker and copper wire must be used (see "Electrical Connections," p.11).

WARNING

The unit must always be powered off before opening the access panel.

Bonding

CAUTION

Because all metals have different electrical potentials, all metal and electrical components of the pool system must be bonded together. This includes the metal framework of the pool, the light, the pump, the filter (if made out of metal), the heater, any automatic chlorine generator, and any other metal or electrical equipment. On some older pools, this substructure bond wire may not exist. In these cases, a 6 to 8 foot solid copper rod must be driven into the ground near the equipment. All electric and metal components must then be bonded to each other, and then to the copper rod.

Bonding and Plumbing step-by-step instructions

1. A 1/3 lb check valve **must** be installed between the heater and any automatic chlorine distribution system (if used).
2. Any kind of automatic chlorine distribution system **must** be installed after or downstream of the heat pump.
3. The filter **must** be placed before or upstream from the heat pump.
4. A bypass and shut-off should be installed on all systems for ease of service, maintenance and to balance the water flow. Bypasses **must** be installed on any system with over a 1 1/2 HP pool pump. (see FIG.3 for different types of possible bypasses)

Bonding and Plumbing diagram

Fig. 2

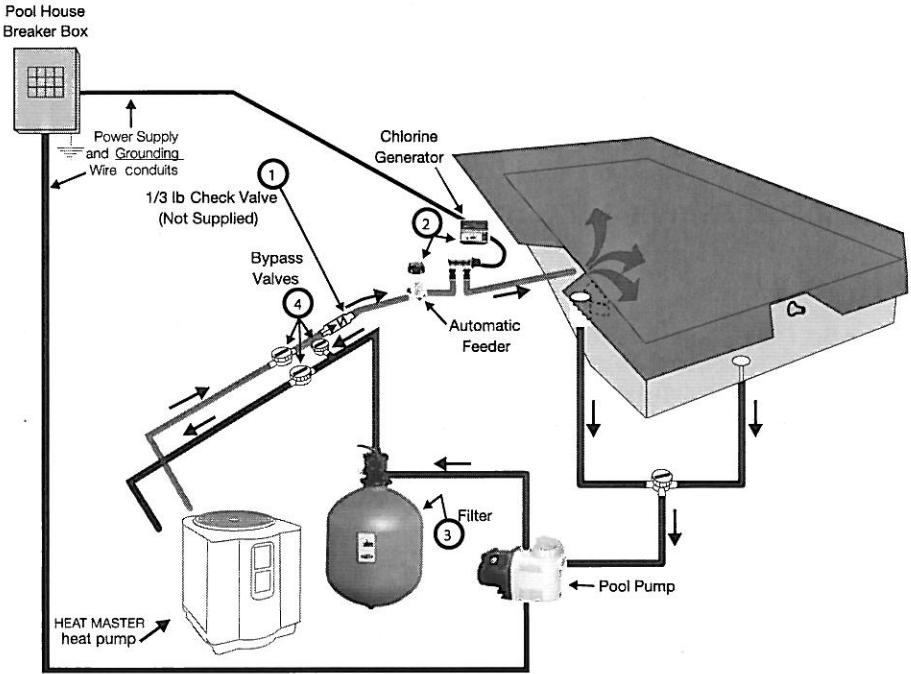
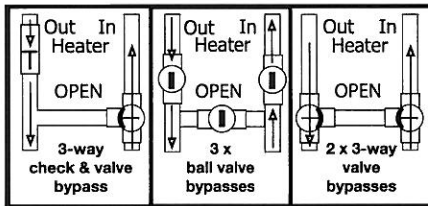

Fig. 3



Using an External Controller

To connect the electronic board in order to control it remotely, use the P_S terminals on the right side of the board. Next, access the P_S menu and select the desired mode. In internal mode, POOL or SPA mode can be adjusted by using this menu. In external mode, a normally open contact puts the board in POOL mode and a closed contact puts the board in SPA mode. Therefore, a board set to OFF in POOL mode and to 80 degrees in SPA mode can be controlled with an external switch to heat up to 80 degrees.

Internal mode: Use the P_S mode on the main menu

External mode:

- Open contact = POOL mode
- Closed contact = SPA mode

Control using a switch

To control the board using an external switch, follow these steps :

- Turn on the heat pump.
- Set POOL mode to OFF.
- Set SPA mode to the desired temperature.
- Access the setup menu.
- Select mode E (external) on the P_S menu.
- Run two J7 (P_S) terminal wires from the HPEC-003 board to the NO switch terminals (see FIG. 4A).
- You can now control the operating mode by turning off the switch (open = POOL, closed = SPA.)

Fig. 4A

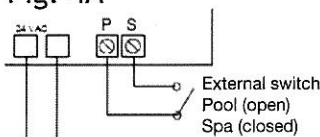

Control using an Aqua Logic system

To control the board by using an Aqua Logic system, follow these steps:

- Turn on the heat pump.
- Set POOL mode to OFF.
- Set the SPA mode to the maximum (104°F).
- Access the setup menu.
- Select mode E (external) on the P_S menu.
- Run two J7 (P_S) terminal wires from the HPEC-003 board to the HEATER RELAY 1 terminals of the Aqua Logic system (see FIG. 4B).
- You can now control the operating mode using the Aqua Logic system remote control.

Fig. 4B

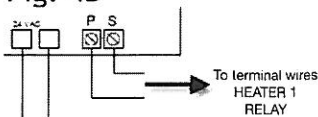

Electrical Connections

WARNING

The installation of the HEAT MASTER pool heater should be performed by a certified electrician. To connect the electricity, you must unscrew the five screws of the front panel, then slide the electric cable in the hole located on the left side of the base, and then insert it in the control box. The electrical diagram is located on the lid of the control box as well as below (see FIG.5).

Power requirements

240 V, 1 PH, 60 Hz

Look at the name plate located on the heat pump to know the required amperage.

Please refer to your local electrical code.

Fig. 5

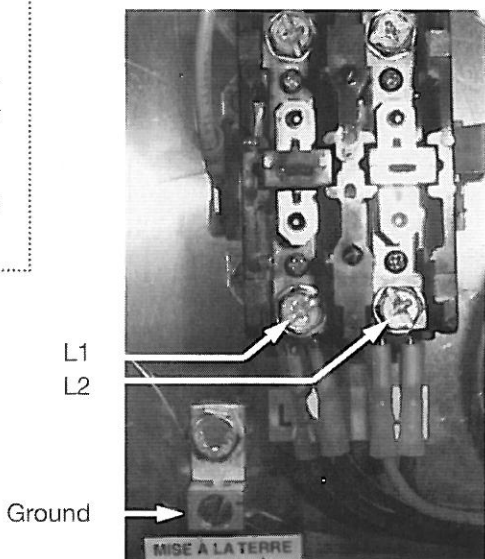

Wiring Diagram

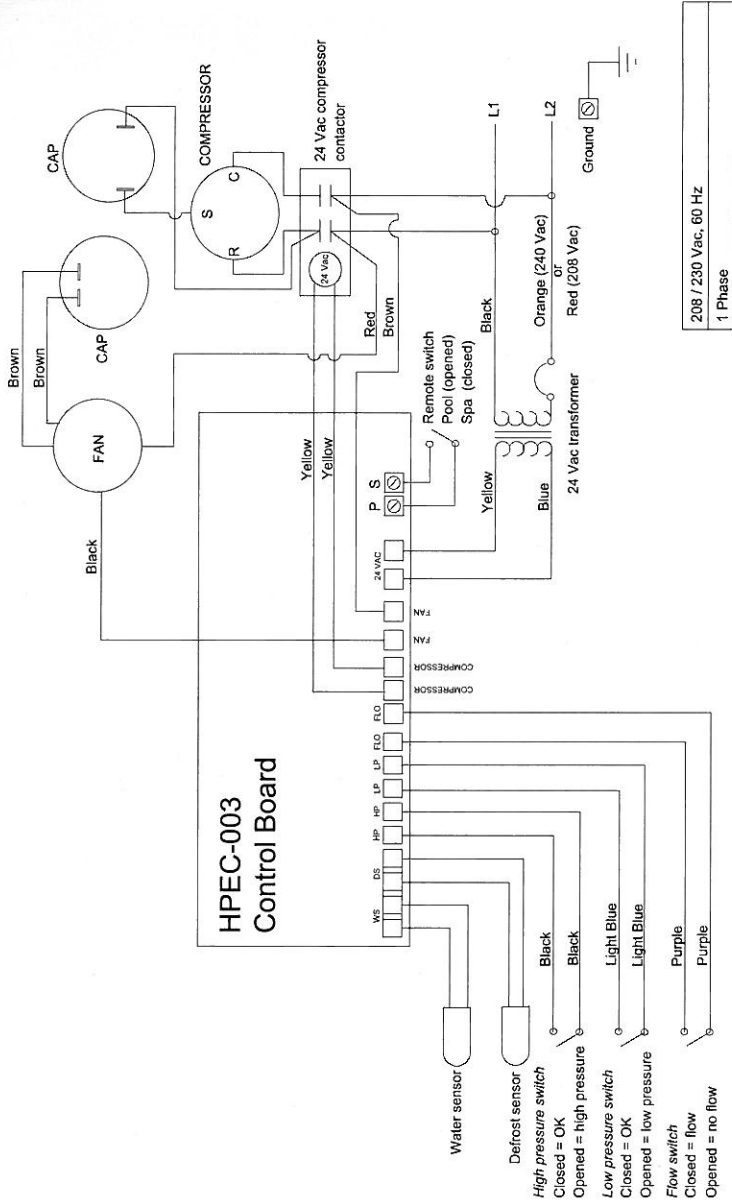

Service Analyzer Control

The control panel is factory set to display the temperature in Fahrenheit degrees.

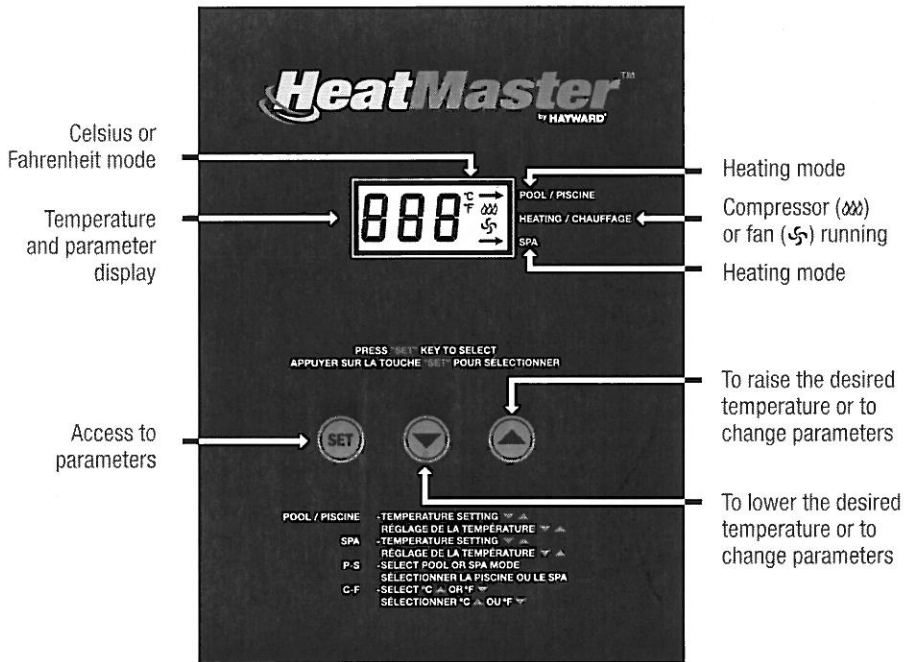

Operation

To increase the temperature

Push the SET key until you see POL or SPA. The programmed temperature will be displayed. Press the UP arrow ▲ to increase the temperature setting one degree at a time.

To lower the temperature

Proceed as explained above using the down arrow ▼.

To select the pool or spa mode

The unit can keep two temperature settings in memory: one for pool mode (max: 95°F/35°C), and the other for spa mode (max: 104°F/40°C). To have access to either program, press the SET key until you see P_S and by pressing one of the arrow keys, you can switch to POL or SPA. Once the heating mode has been programmed, it will be displayed for five seconds, and will then return to the actual pool water temperature. The lights on the right side of the display indicate the chosen heating mode.

To display the temperature in °F or in °C

Press the SET key until you see F_C and by pressing one of the arrow keys, you can switch to °F or °C. Once the heating mode has been programmed, it will be displayed for five seconds, and will then return to the actual pool water temperature in the mode that you have chosen.

Caring for your Pool Heater

How to protect your pool heater

This Flow Chart will teach you the steps to follow to protect your heater as well as your family by maintaining a corrosion free pool.

INSTALLATION
- Verify that the installation was done according to owner's manual instructions.

FIRST TIME OR SPRING STARTUP
- Hook up pool water piping but do not hook up the Heater yet.

VERIFY & BALANCE POOL CHEMICAL

NO
POOL CHEMICAL OK?

YES
HOOK UP WATER PIPING TO HEATER

SET REQUIRED WATER TEMPERATURE ON TOUCH PAD

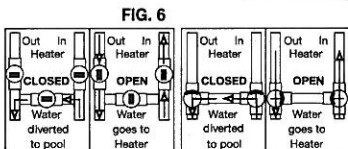

IMPORTANT FOR THE HEALTH OF YOUR FAMILY AND FOR YOUR POOL HEATER
- Verify Chlorine or Bromine level every 2-3 days
- Verify PH level once a week
- Verify Alkalinity level every 3-4 weeks (More often if you own an Automatic Chlorine or Bromine Feeder.)
(Above tests can easily be done by yourself with a do it yourself kit)
- Verify Hardness and Total Dissolved Solids (TDS) once a month
(Above tests must be done by your dealer)

NO
HEATING WILL NOT BE REQUIRED FOR MORE THAN A WEEK?

YES
Shut Bypass valves and disconnect waterlines to drain the HEATER.

YES
HEATING NEEDED?

NO

NO
IS IT POOL CLOSING TIME?

YES

**CLOSE POOL
PROTECT HEATER BY COVERING IT**

INSTALLATION
When heating is not required for less than a week you **MUST** leave the Bypass valves open (See Fig.6) to let the water circulate in the unit. If the heat exchanger is deprived of water circulation for more than 72 hours, high chlorine gas could cause excessive corrosion.

Initial Startup

IMPORTANT

Before starting the pool heater for the first time, it is important to verify that the breaker is in the ON position.

Also make sure that the water circulates freely and that the pool pump is activated.

Then, you will need to set the water temperature you desire. The fan will immediately start. The compressor will start after a 3 to 4-minute delay.

When the compressor is running, the **CHAUFFAGE/HEATING** indicator located on the right (see "Service Analyzer Control," p. 13) should be lit. At initial startup, it is normal for the unit to run 24 hours a day.

It is also normal to see water dripping from the holes at the base of the unit. This is just condensation.

Meaning of Display Codes

Service Analyzer Codes

Most problems will be detected by the service analyzer and a code will be displayed on the digital display of your heater.

Display Meaning of codes

OFF	The desired programmed temperature point is lower than 60°F (15°C).
LP & LP3	Shortage of refrigerant gas in the unit or faulty low pressure control. The digital display will show LP3 after 3 LP faults and shut down your pool heater. The pool pump will also be stopped for protection if the unit's internal time clock feature is used. If LP or LP3 occurs you should call for service.
HP & HP3	Low water flow to the unit or faulty high pressure control. Check water flow. Backwash filter and/or heater. The unit will show HP3 after 3 HP faults. This will stop your heater for protection.
Po	Water temperature probe connected to #1 and #2 on electronic board may be disconnected. If it is not, the probe may be open or defective.
Pc	Water temperature probe is short circuited or may be defective.
FLo	Possible causes: <ul style="list-style-type: none">- The filter is in backwash position.- The filter pump is stopped.- The filter is dirty.- Shortage of water to pool pump.- Water pressure switch must be adjusted or it is broken.
dPo	Suction temperature probe connected to #3 and #4 on electronic board may be disconnected. If it is not, the probe may be open or defective.
dPc	Suction temperature probe is short circuited or may be defective.
FS	Unit currently in defrosting cycle (the fan works but the compressor is stopped). This is normal operation when outside temperatures are cold.

Troubleshooting

The pool heater is not running.

Heat pump control set to OFF. ♦♦♦♦ Raise temperature set point above 60°F (15°C).

Desired water temperature is reached. ♦♦♦♦ Unit will automatically restart when the water temperature goes below the set point.

Main breaker is tripped. ♦♦♦♦ Reset it.

The heater is displaying “flo” and it will not start.

Pool pump is not running. ♦♦♦♦ Turn the pool pump on.

Filter is dirty, restricting the water flow. ♦♦♦♦ Backwash and clean filter.

The fan is running, but the compressor is not.

The heat pump is in protection mode. ♦♦♦♦ In this case, there may be a 5-minute delay before restarting.

The unit is on defrost cycle. ♦♦♦♦ Digital display should indicate FS. The compressor will automatically start again a few minutes after the display stops indicating FS.

There is no display and the fan is not running, but the compressor is running.

- ◆ Ask your electrician to verify your heat pump's power supply by checking over the L1 and L2 connections in the unit's service box.

There is water around the unit.

While your HEAT MASTER pool heater is in the heating mode, a large quantity of warm and humid air passes over the evaporator and causes condensation. It is normal to see condensation dripping under the heater.

- ◆ To check if the water really is a leak, you must stop the heater and leave the pool pump running for over 5 hours. If water is still coming out of your heater after this period, then call your dealer for service.

The heater is running but desired water temperature cannot be reached.

- ◆ Heat loss is too much for the heater; cover your pool as often as you can.

Evaporator is dirty.

- ◆ Clean it.

- ◆ Evaporator restricted due to improper location (see "Location", p.6).

Restricted water flow.

- ◆ Adjust water flow.

Note: If your pool heater does not operate for reasons other than those mentioned above, please contact **Consumer Assistance Center** (see "Introduction", p. 2) to obtain the proper authorization for the warranty to apply.

Requesting Assistance or Service

IMPORTANT

All service will be handled by an Authorized Service Center. Warranty may be voided if service is not done by an Authorized Service Representative. Do not return the heater to your dealer as they do not provide service.

Before calling for assistance or service, please check the “Troubleshooting” (pp. 18-19) and “Warranty” (p. 22) sections or call your dealer. It may save you the cost of a service call. If you still need help, follow the instructions below.

Service can be obtained by calling one of these phone numbers.

CANADA: 1 888 238-7665

USA: 1 908 355-7995

When asking for help, please provide a detailed description of the problem, your heater’s complete model and serial number, and the purchase date (see p. 3). This information will help us respond properly to your request.

Keep a copy of the sales receipt showing the date of purchase. Proof of purchase will assure you warranty service.

Maintenance

Dirt can accumulate on the evaporator. You can easily remove it by using a water spray without damaging the small aluminum fins.

The cleaning of the plastic cabinet can be done with the help of a brush and soap.

Winterizing

First, you must turn the breaker off. The unit must be drained of all its water. You will need to disconnect the IN and OUT water connections. Then the unit must be tilted or blown out with air until all water is out.

The next step is to reconnect your IN and OUT water connections that will have previously been drained.

It is recommended to cover the heat pump to prevent snow from getting inside. A protective winter cover is also offered by your retailer.

Pool Heat Pump Warranty

Hayward Industries warrants that the HEAT MASTER pool heat pump will be free of defects in workmanship and materials. The heat pump will be warranted for a period of two (2) years*. All parts and labor to correct any defect in workmanship or materials will be the responsibility of Hayward Industries.

The compressor component of the HEAT MASTER pool heat pump has a five (5) year limited warranty. During the first two (2) years*, the costs incurred by the parts and labor needed to repair the compressor will be the responsibility of Hayward Industries. During years three (3), four (4) and five (5), only parts will be covered by the warranty.

The titanium tube portion of the heat exchanger in the HEAT MASTER pool heat pump has a limited 10-year warranty**. The titanium tube portion of the heat exchanger is warranted to the original owner and at the original address. All parts and labor are warranted for a period of two (2) years* to the original home owner. After two (2) years*, only the titanium tube portion of the heat exchanger part is warranted.

All HEAT MASTER pool heat pump must be installed according to manufacturer's specifications or the warranty will be null and void.

All warranty work must be performed by a Hayward Industries authorized service center. All warranty work must be approved prior to service center performing the work.

Any alteration or repair by any person, agency or company not authorized by Hayward Industries will void the warranty. Hayward Industries is not liable for any damages of any sort whatsoever, including incidental and consequential damages. This warranty does not include damage to any internal piping or components due to freezing conditions, negligence, abuse, routine maintenance inspections, electrical wiring outside the heat unit, service calls caused by owner, external valve position, refrigerant or other expendable materials, installations in corrosive environments or atmospheres, nor acts of God. There are no particular warranties of merchantability that apply to this product.

This warranty applies to Canada and the United States.

Hayward Industries will replace or repair any parts that are defective providing such parts are returned to the HEAT MASTER factory, freight collect, within the warranty period. The above is the exclusive remedy from Hayward Industries.

* The 2-year warranty applies only in Canada or within the State of Florida. In the USA, outside the State of Florida, the HEAT MASTER pool heat pump is warranted for a period of two (2) years for parts and one (1) year for labor.

** Except for the HML50T that has a 5-year warranty against corrosion on the heat exchanger.

