

HAYWARD®

Installation, Operation & Service Procedures Above Ground Pool Heater Models H100ID1 & ABG1001

Unit must be installed outdoors only
and below an altitude of 2000 feet

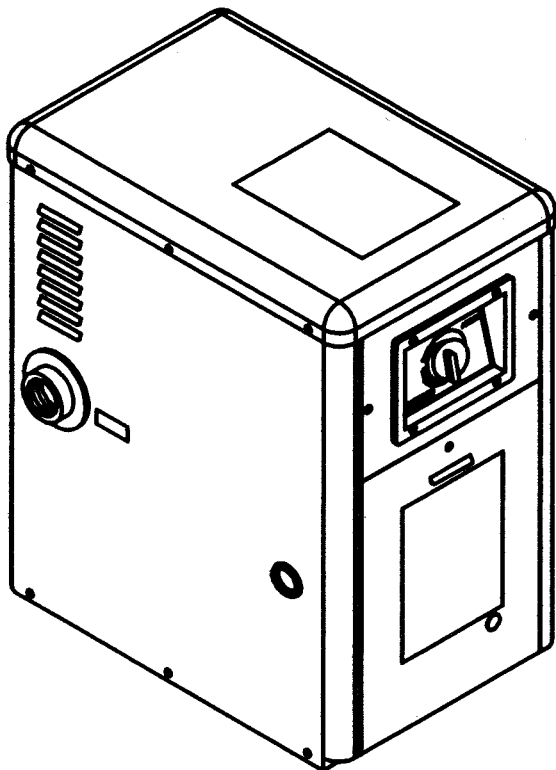

FOR YOUR SAFETY

WARNING: If the information in these instructions is not followed exactly, a fire or explosion may result causing property damage, personal injury or death.

- Do not store or use gasoline or other flammable vapors and liquids in the vicinity of this or any other appliance.

WHAT TO DO IF YOU SMELL GAS

- Do not try to light any appliance.
 - Do not touch any electrical switch; do not use any phone in your building.
 - Immediately call your gas supplier from a neighbor's phone. Follow the gas supplier's instructions.
 - If you cannot reach your gas supplier, call the fire department.
- Installation and service must be performed by a qualified installer, service agency or the gas supplier.

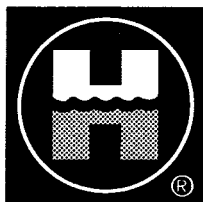

Section I. General Information

Important notice:

The instructions herein are intended for the use of a qualified technician, specifically trained and experienced in the installation of this type of heating equipment. Some states or provinces require that installation and service personnel performing the installation be licensed. If this is the case in the state or province where this heater is located, the contractor must be properly licensed.

▲WARNING: Failure to comply with the appliance installation instructions and service instructions in this manual may result in equipment damage, fire, asphyxiation or carbon monoxide poisoning. Exposure to products of incomplete combustion (carbon monoxide) can cause cancer and birth defects or other reproductive harm.

Conformance with codes:

The heater shall be installed in accordance with all local and state codes. The heater installation must conform to the latest edition of the National Fuel Gas Code ANSI Z223.1 and with the requirements of the authority having jurisdiction. Design Certification in the United States is in compliance with American National Standard Z21.56 (latest edition).

For Canadian installations, the heater must be installed in accordance with standards CAN/CGA B149.1 and B149.2 - INSTALLATION CODES FOR GAS BURNING APPLIANCES AND EQUIPMENT and/or local codes, and if applicable, Standard CSA C22.1 - CANADIAN ELECTRICAL CODE, Part 1.

Location of heater:

Locate the heater in an area where a leaking heat exchanger or connection leak will not result in damage to the area adjacent to the heater or structure.

This heater must be installed at least five feet from the wall of an above-ground pool.

The heater shall not be installed with the top of the vent assembly within 10 feet below or to either side of any opening into the building.

Outdoor installation Only:

The following installation and service clearances must be maintained from surfaces to provide adequate air flow to the heater.

Outdoor Installations	
Top - Unobstructed	Right side - 10 inches
Front - 10 inches	Left side - 10 inches
Back - 10 inches	Bottom - Combustible floor

Figure 1

An A.G.A. Certified main gas valve shutoff must be installed outside of the cabinet and within 6 feet of the heater. Gas shutoff valve must have an inside diameter large enough to supply the proper amount of gas volume to the heater.

▲NOTE: Do not use flexible appliance connectors on any gas connections unless the connector is A.G.A. approved for outdoor installation, is marked with the BTUH capacity (which must be equal to or greater than 100,000 BTUH), and the type of gas (Natural or LP) to be used.

Propane gas:

All propane tanks must be located outdoors away from the pool and in accordance with the standard for storage and handling of propane gas, ANSI/NFPA 58 (latest edition) and applicable local codes. If propane gas tank is

installed underground, the discharge of the regulator vent must be above the highest probable water level.

Propane tanks must be sufficient capacity to provide adequate vaporization for the full capacity of the equipment at the lowest expected temperatures. Consult a propane company expert for correct sizing.

Water piping:

This heater is designed for use with pool and spa/hot tub water only, as furnished by municipal water distribution systems. The warranty does not cover heater use with mineral water, sea, salt or other non-potable waters.

Do not install any restriction in the water pipe between heater outlet and pool/spa with the exception of a three-way switching valve and associated check valve. Blockage of water flow from heater return to pool may result in fire or explosion causing property damage, personal injury or loss of life.

Plumbing connections:

Water flow rate to the pool must be between 20 and 70 gpm. If flow rate exceeds 70 gpm an external by-pass valve must be installed. Figure 2 shows a typical heater installation.

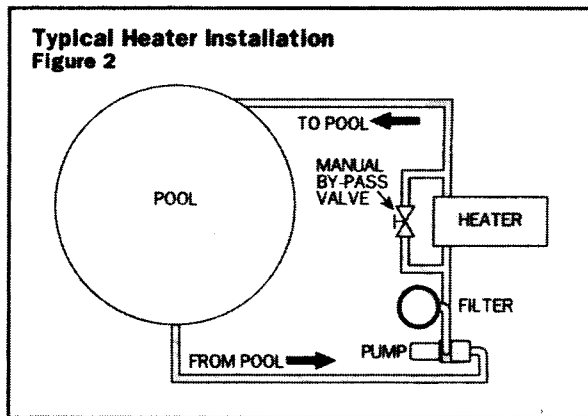

Electrical system:

This heater is equipped with a standard 3-prong 120 volt cordset. The plug must be inserted into a GFI protected, watertight, outdoor receptacle rated for at least 10 amps. The heater must be electrically grounded and bonded in accordance with local codes, or in the absence of local codes, with the National Electrical Code, ANSI/NFPA 70.

If the heater must be hard wired, open the junction box and disconnect the cord. Remove the cord and strain relief and wire the heater in accordance with local codes or the National Electrical Code.

The ignition system used to light the burners is a direct spark system which requires 120 volt AC current as does the blower motor. The system amp draw is 2 amps.

It is strongly recommended that the heater be supplied with a constant power source. If remote operation is required, the heater should be controlled through the thermostat only.

Installation above or below water level:

This heater is supplied with a pressure switch factory set at 3.0 psi. If the heater does not operate and the pressure switch is at fault, the following procedure is recommended to adjust the switch:

1. Clean filter thoroughly.
2. Set heater thermostat to highest setting.
3. Start filter pump. Make sure all air is out of water lines and complete system is full of water.
4. Place a 5/64" allen head wrench in the adjusting socket on the front of the switch and turn it

5. To check operation, turn the pump on and off several times. The heater should shut off immediately when the pump is shut off.

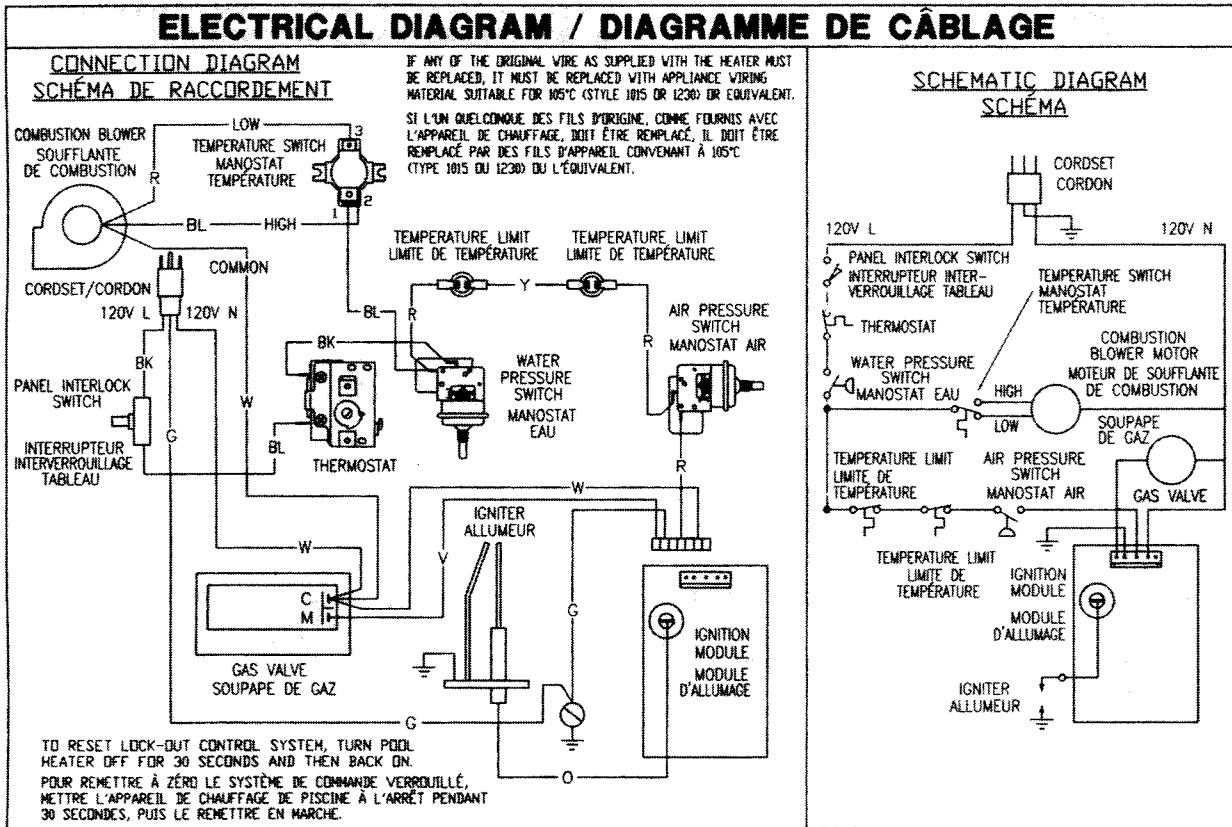

Section II. Installer

Gas line testing:

The appliance and its gas connection shall be leak tested before placing in operation. The heater and its individual shutoff valve must be disconnected from the gas supply piping system during any pressure testing of that system at test pressures in excess of 1/2 psig. The heater must be isolated from the gas supply piping system by closing its individual manual shutoff valve during any pressure testing of the gas supply piping system at test pressures equal to or less than 1/2 psig.

Gas supply line must be capped when not connected. After pressure testing, reconnect the gas piping to the gas valve. Turn gas supply on and test all pipe and pilot tubing joints for leaks. Use a soap and water solution. Bubbles forming indicate a leak. **Never use an open flame (match, lighter, torch, etc.) as a leak could cause an explosion or injury.** Shut off gas and fix even the smallest leak immediately. Be sure to leak test the main burner fittings using the above procedure once the heater is in operation.

Gas pressure test procedure:

The following gas pressure adjustments are important to proper operation of the heater. Incorrect settings can cause improper operation.

1. Turn pump, main gas valve and heater power on. Start heater following lighting instructions.
2. Using a manometer, determine the inlet gas pressure. The inlet gas pressure must not exceed 10.5" W.C. (water column pressure) for Natural gas or 13" W.C. for Propane gas. **Exposure to higher pressures can damage the gas control valve, causing leaks or diaphragm rupture.** This damage could result in fire, explosion or burner overfiring leading to carbon monoxide poisoning. The inlet gas pressure must not be below 3.0" W.C. for Natural gas and for Propane. The heater may fail to operate at low inlet gas pressures. If the inlet gas pressure is too high or too low, the installer must contact the gas supplier and request that the inlet pressure to the heater be adjusted.
3. Using a manometer, determine the gas operating pressure. Manifold pressure for both natural and propane gas is 2.0" W.C. The gas valve is preset to operate at this pressure, no adjustment is necessary.

Gas pipe size:

Figure 4

Follow local gas codes for proper gas line material selection (copper, iron or plastic etc.)

LOW PRESSURE NATURAL GAS PIPE SIZING:
(Based upon gas pressure of 0.5 psig or less and a pressure drop of 0.5" W.C.)

Distance from Meter (Natural Gas)	Iron Pipe
0 to 25 feet	1/2"
25 to 100 feet	3/4"
100 to 200 feet	1"

LOW PRESSURE PROPANE GAS PIPE SIZING "SINGLE STAGE": (Based upon gas pressure of 11" W.C. inlet pressure and a 0.5" W.C. pressure drop)

Distance from Tank (Propane)	Iron Pipe	Tubing
0 to 25 feet	3/8"	5/8"
25 to 100 feet	1/2"	3/4"
100 to 200 feet	3/4"	7/8"

It is **VERY IMPORTANT**, when installing a propane heater on a two (2) stage regulation system, to follow the gas line sizing chart below—without exception.

HIGH PRESSURE "TWO STAGE" SYSTEMS:

HIGH PRESSURE PROPANE GAS PIPE SIZING "FIRST STAGE": (Based upon gas pressure of 10 psig inlet pressure at a pressure drop of 1 psi.)

Distance from outlet of 1st stage regulator to inlet of 2nd stage regulator	Iron Pipe	Tubing
0 to 200 feet	1/2"	1/2"

LOW PRESSURE PROPANE GAS PIPE SIZING "SECOND STAGE": (Based upon gas pressure of 11 inches W.C. inlet pressure at a pressure drop of 0.5 inch W.C.)

Distance from outlet of 2nd stage regulator to inlet of gas valve	Iron Pipe	Tubing
0 to 10 feet	1/2"	1/2"

Section III. Consumer Operation & Maintenance

FOR YOUR SAFETY – READ BEFORE OPERATING

General:

Do not operate the heater without water flowing through it.

Do not use the heater if any part has been under water. Contact a qualified service technician to inspect the entire heater and replace any part of the control system or gas valve that was under water. If heater has been totally submerged in water, replace the entire heater.

Pool/Spa water chemistry:

See also Figure 5. The mineral content of swimming pool water increases daily due to addition of pool sanitizing chemicals and natural evaporation. Excess minerals will deposit on pool walls, in the filtration system, and in the heat exchanger tubes if the mineral content is too high.

Changing spa water regularly and maintaining correct chemical balance in pool/spa will keep the pool/spa safe and sanitary, and will protect heater and its warranty coverage. Purchase a good "DPD" water test kit and check the following chemical levels frequently:

CHLORINE OR BROMINE – Recommended level 1 to 4 ppm. Test before use.

pH – Recommended ideal level 7.4 to 7.6. **HIGH** readings reduce sanitizer efficiency. **LOW** readings are corrosive.

TOTAL ALKALINITY – 80 to 120 ppm. Test weekly during regular use. **LOW** readings are corrosive and cause rapid pH changes when chemicals are added.

CALCIUM HARDNESS – 200 to 400 ppm. Test whenever pool/spa is filled. **LOW** levels of hardness can be very corrosive.

Remember, addition of any chemicals can change levels of chlorine, pH, and total alkalinity.

It is recommended that residential spa water be changed every 2 to 3 months to prevent water problems. Public spas may need to have the water changed every week, or even daily, depending on bather load.

Using chlorinators and chemical feeders:

Follow the instructions provided with any automatic or manual chlorinator and chemical feeder. If a chlorinator is used, it must be installed down stream from the heater in the pool return line. Install a check valve between the heater outlet and chlorinator to prevent chlorine from siphoning back into the heater. All chemicals must be introduced and diluted into the pool or spa water before being circulated through the heater. Do not place chlorine tablets or bromine sticks directly into the skimmer. High chemical concentrations may result when the pump is not running. High chemical concentrations cause very rapid corrosion of the heat exchanger. Such damage is not covered under warranty.

Facts about water chemistry:

FACTORS which affect pool/spa water and, more importantly, the efficiency and operation of the pool/spa heater.

1. PROPER FILTRATION
2. PROPER CIRCULATION
3. DISINFECTION AND OXIDATION
4. pH CONTROL AND TOTAL ALKALINITY
5. ALGAE CONTROL

What is pH? It is the measure of the acidity or alkalinity of water. As shown on this chart, it is a critical measurement.

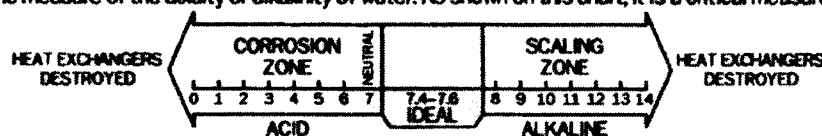

Hayward recommends using a four way test kit to obtain...

1. MIN./MAX. pH (7.2 - 7.8)
2. CHLORINE RESIDUAL (1.0 - 3.0 PPM), BROMINE (2.0 - 4.0 PPM)
3. TOTAL ALKALINITY (80 - 100 PPM) for calcium, lithium and sodium hypochlorite, or (100 - 120 PPM) for sodium dichlor, trichlor, and bromine.
4. CALCIUM HARDNESS (200 - 400 PPM)

Figure 5

Heater operation:

Full lighting and shutdown instructions are included on the lighting instructions label installed on the front access door inside the heater cabinet. This heater cannot be operated with the front door removed.

▲ WARNING: If you smell gas in the appliance area or near the floor stop, and follow instructions on front cover of this manual.

▲ NOTE: Do not use this unit below 40°F temperature. Do not operate heater while an automatic pool cleaner is in use.

▲ NOTE: This unit will not operate if water flow is insufficient. Make sure filter is clean.

▲ Warning:

Do not ingest alcohol or drugs during use or prior to using pool. Ingestion of such intoxicants can cause drowsiness which can lead to unconsciousness and subsequently result in drowning.

Do not heat pool water in excess of 102°F. A temperature of 100°F is considered safe for a healthy adult. Hotter water increases the risk of hyperthermia. Special caution is suggested for younger children.

Pregnant women beware! Soaking in water above 102°F can cause fetal damage during first three months of pregnancy (resulting in the birth of a brain damaged or deformed child). Pregnant women should adhere to the 100°F maximum rule.

Before entering the water, users should check the water temperature with an accurate thermometer; operating thermostats may err in regulating water temperatures by as much as four degrees F.

Persons with a medical history of heart disease, circulatory problems, diabetes or blood pressure problems should obtain their physician's advice before using spas or hot tubs.

Persons taking medications which induce drowsiness, such as tranquilizers, antihistamines or anticoagulants,

should not use spas or hot tubs.

If the pool/spa is used for therapy, it should be done with the advice of a physician. Always stir the water before entering to mix in any hot surface water that might exceed healthful temperature limits and cause injury.

Do not tamper with controls, because scalding can result if safety controls are not in proper order.

Temperature controls:

The heater is turned "ON" and "OFF" and the water temperature is adjusted with the thermostat. Turning the thermostat all the way counterclockwise will turn the heater "OFF." Turning the thermostat clockwise will turn the heater "ON" and adjust the temperature higher.

The memory stop provides a manual means of locking the desired maximum temperature setting of the water. Once the maximum setting has been determined, loosen the screw and rotate the stop to the desired location and retighten the screw.

Periodic inspection:

1. Periodically check the venting system on the heater. The venting areas must never be obstructed in any way and minimum clearances must be observed to prevent restriction of combustion and ventilation air.
2. Keep the entire pool area clean and free of all debris, combustible materials, gasoline and other flammable vapors and liquids. Remove any leaves or paper from around the heater.
3. Do not store chlorine, other pool chemicals or other corrosives in the vicinity of the heater.

Winterization:

Do not operate heater if the temperature falls below 40°F. Drain all water out of heater to prevent damage to heat exchanger during freezing weather.

Section IV. Qualified Technician - Servicing

General:

▲ WARNING: Do not attempt to repair any components of the heater. Do not modify heater in any manner. To do so may result in a malfunction which could result in death, personal injury or property damage. Check with consumer to see if any part of heater has been under water. Replace any part of the control system and any gas control which has been under water. Never use or attempt to use parts that have been previously used.

▲ CAUTION: Label all wires prior to disconnection when servicing controls. Wiring errors can cause improper and dangerous operation. Verify proper operation after servicing.

Burner cleaning:

If required, burners can be cleaned in the following manner:

1. Turn pump, main gas valve and heater power off.
2. Remove the gas manifold.
3. Remove the burners.
4. Brush burners with a wire brush and check that they are free of lint, dust and spider webs before each season of use. Burners with damaged ports must be replaced.

Gas valve replacement:

▲ WARNING: Do not attempt to repair gas valve. If found to be defective, replace entire valve. Attempts to repair it will void warranty.

1. Turn pump, main gas valve and heater power off.
2. Disconnect wires to gas valve.
3. Unscrew gas valve from manifold.
4. Install new valve
5. Reconnect wires to gas valve

Direct spark module:

The direct spark ignition module is the master control, processing the operational information from the other controls. When the thermostat calls for heat, the blower turns on for 10 seconds before the ignitor begins to spark. The ignitor begins sparking at the same time the main gas valve opens, which causes ignition of the main burner gas. If ignition does not happen within 10 seconds, the module will try to light for (3) consecutive tries at 30 second intervals. If no ignition is received the control will lock out for 1 hour. To reset the module, the thermostat must be turned to the "OFF" position and back "ON".

To replace the module:

1. Turn pump, main gas valve and heater power off.
2. Unplug heater.
3. Disconnect wires from the module.
4. Remove module retaining screws.
5. Replace module.

Combustion blower:

The combustion blower provides the air that mixes with the gas from the main burners for the combustion process. On initial start-up, the blower operates for 10 seconds to purge gas out of the heater. Then, the main gas valve opens, the ignitor sparks for a maximum of 10 seconds and the heater lights. The blower operates the entire time the gas valve is open.

Combustion blower replacement:

1. Turn pump, main gas valve, thermostat and heater power "OFF".
2. Remove screws retaining the main top.
3. Disconnect wires attached to the blower.
4. Remove external vent terminal.
5. Remove duct from blower to vent terminal.
6. Remove screws attaching blower to flue collector.
7. Replace blower.
8. Reverse above procedure for installation.

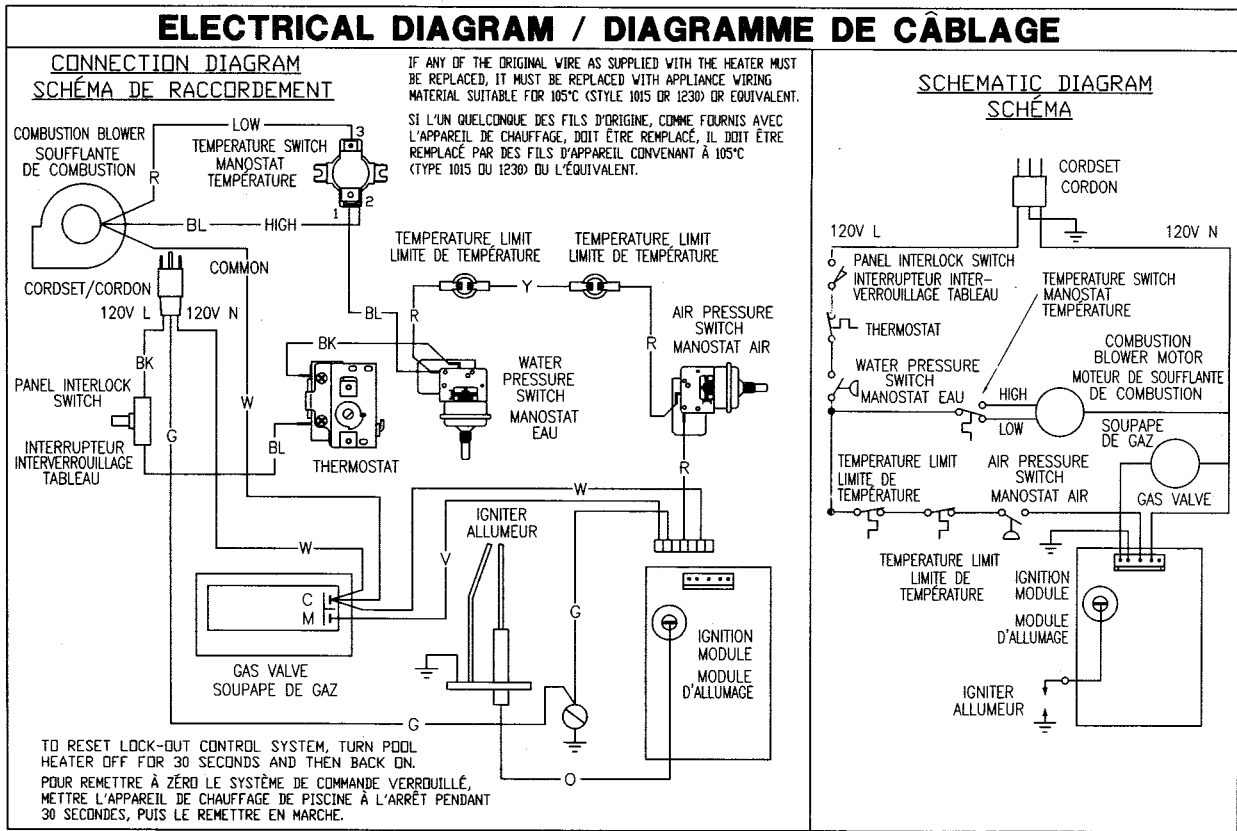

FOR YOUR SAFETY READ BEFORE LIGHTING

WARNING: If you do not follow these instructions exactly, a fire or explosion may result causing property damage, personal injury or loss of life.

- This appliance does not have a pilot. It is equipped with an ignition device which automatically lights the burners. Do **not** try to light the burners by hand.
- BEFORE LIGHTING** smell all around the appliance area for gas. Be sure to smell next to the floor because some gas is heavier than air and will settle on the floor.

WHAT TO DO IF YOU SMELL GAS

 - Do not try to light any appliances.
 - Do not touch any electric switch; do not use any phone in your building.
 - Immediately call your gas supplier from a neighbor's phone. Follow the gas supplier's instructions.
 - If you cannot reach your gas supplier, call the fire department.
- Use only your hand to turn the gas control knob. Never use tools. If the knob will not turn by hand, don't try to repair it; call a qualified service technician. Force or attempted repair may result in a fire or explosion.
- Do not use this appliance if any part has been under water. Immediately call a qualified service technician to inspect the appliance and to replace any part of the control system and any gas control which has been under water.
- Should over-heating occur, or the gas supply fails to shut off, turn off manual gas valve to the appliance.

POUR VOTRE SÉCURITÉ LISEZ AVANT L'ALLUMAGE

MISE EN GARDE: Si vous ne suivez pas exactement ces instructions, un incendie ou une explosion pourrait survenir et causer des dommages à la propriété, des blessures corporelles ou la perte de la vie.

- Cet appareil n'a pas de pilote. Un mécanisme d'allumage automatique pour les brûleurs. **N'essayez pas d'allumer les brûleurs à la main.**
- AVANT L'ALLUMAGE**, sentez tout autour de l'appareil pour détecter d'éventuelles odeurs de gaz. S'assurer de sentir près du plancher parce que les gaz plus lourds que l'air se concentrent au niveau du plancher.

QUE FAIRE EN PRÉSENCE D'ODEURS DE GAZ:

 - Ne pas essayer d'allumer l'appareil.
 - Ne pas toucher à un commutateur électrique; Ne pas utiliser le téléphone dans la maison.
 - Appeler immédiatement fournisseur de gaz chez un voisin. Suivre les instructions du fournisseur de gaz.
 - Si le fournisseur ne peut pas être atteint, appeler le service des incendies.
- Utiliser uniquement les mains pour actionner les boutons de commande du gaz. Ne jamais utiliser d'outils. Si le bouton ne s'enfonce pas ou ne se tourne pas à la main, ne pas essayer de le réparer. Appeler un technicien qualifié. L'utilisation de la force ou une tentative de réparation pourrait causer un incendie ou une explosion.
- Ne pas utiliser cet appareil si une des composantes a été immergée dans l'eau. Appeler immédiatement un technicien qualifié pour vérifier l'appareil et remplacer toute composante du système de commande ou de gaz qui aurait été immergée dans l'eau.
- Si le système surchauffait ou si le gaz refusait de se fermer, placer le robinet d'arrêt manuel de gaz de l'appareil en position fermé.

OPERATING INSTRUCTIONS

- STOP!** Read the safety information above on this label.
- Turn the thermostats on the control panel to the "OFF" setting.
- Remove the heater front door.
- This appliance is equipped with an ignition device which automatically lights the burners. Do **not** try to light the burners by hand.
- Turn gas control knob to "OFF".
- Wait five (5) minutes to clear out any gas. If you then smell gas, **STOP!** Follow "B" in the safety information above on this label. If you don't smell gas, go to next step.
- Turn gas control knob to "ON".

GAS CONTROL KNOB SHOWN IN "OFF" POSITION
BOUTON DE COMMANDE DU GAZ ILLUSTRÉ À LA POSITION "OFF"
- Replace the heater front door.
- Turn the thermostats on the control panel to the desired setting.
- If the appliance will not operate, repeat steps 2 thru 9. If the appliance will not operate after 1 retry, follow instructions "TO TURN OFF GAS TO APPLIANCE" and call your service technician or gas supplier.

CONSIGNES DE FONCTIONNEMENT

- ATTENTION!** Lire les consignes de sécurité qui précèdent sur cette étiquette.
- Tourner les thermostats du tableau de commande au réglage "OFF".
- Retirer la porte avant de l'appareil de chauffage.
- Cet appareil est pourvu d'un dispositif d'allumage qui allume automatiquement les brûleurs. **Ne pas tenter d'allumer les brûleurs à la main.**
- Tourner le bouton de commande du gaz à la position "OFF".
- Attendre cinq (5) minutes que tout gaz se dissipe. Arrêter si on sent alors une odeur de gaz. Suivre "B" dans les consignes de sécurité qui précèdent sur cette étiquette. Passer à l'étape suivante en l'absence d'odeur de gaz.
- Tourner le bouton de la commande de gaz à la position "ON".
- Remettre la porte avant de l'appareil de chauffage en place.
- Tourner les thermostats du tableau de commande au réglage désiré.
- Si l'appareil ne fonctionne pas, répéter les étapes 2 à 9. Si l'appareil ne fonctionne pas après un nouvel essai, suivre les instructions "POUR COUPER LE GAZ À L'APPAREIL" et appeler son technicien de service ou fournisseur de gaz.

TO TURN OFF GAS TO APPLIANCE

- Turn thermostat knob on control panel to the "OFF" setting.
- Remove the heater front door.
- Turn gas control knob to "OFF".
- Replace the heater front door.

POUR COUPER LE GAZ À L'APPAREIL

- Tourner le bouton de thermostat du tableau de commande au réglage "OFF".
- Retirer la porte avant de l'appareil de chauffage.
- Tourner le bouton de commande du gaz à la position "OFF".
- Remettre la porte avant de l'appareil de chauffage en place.

Parts List & Illustration

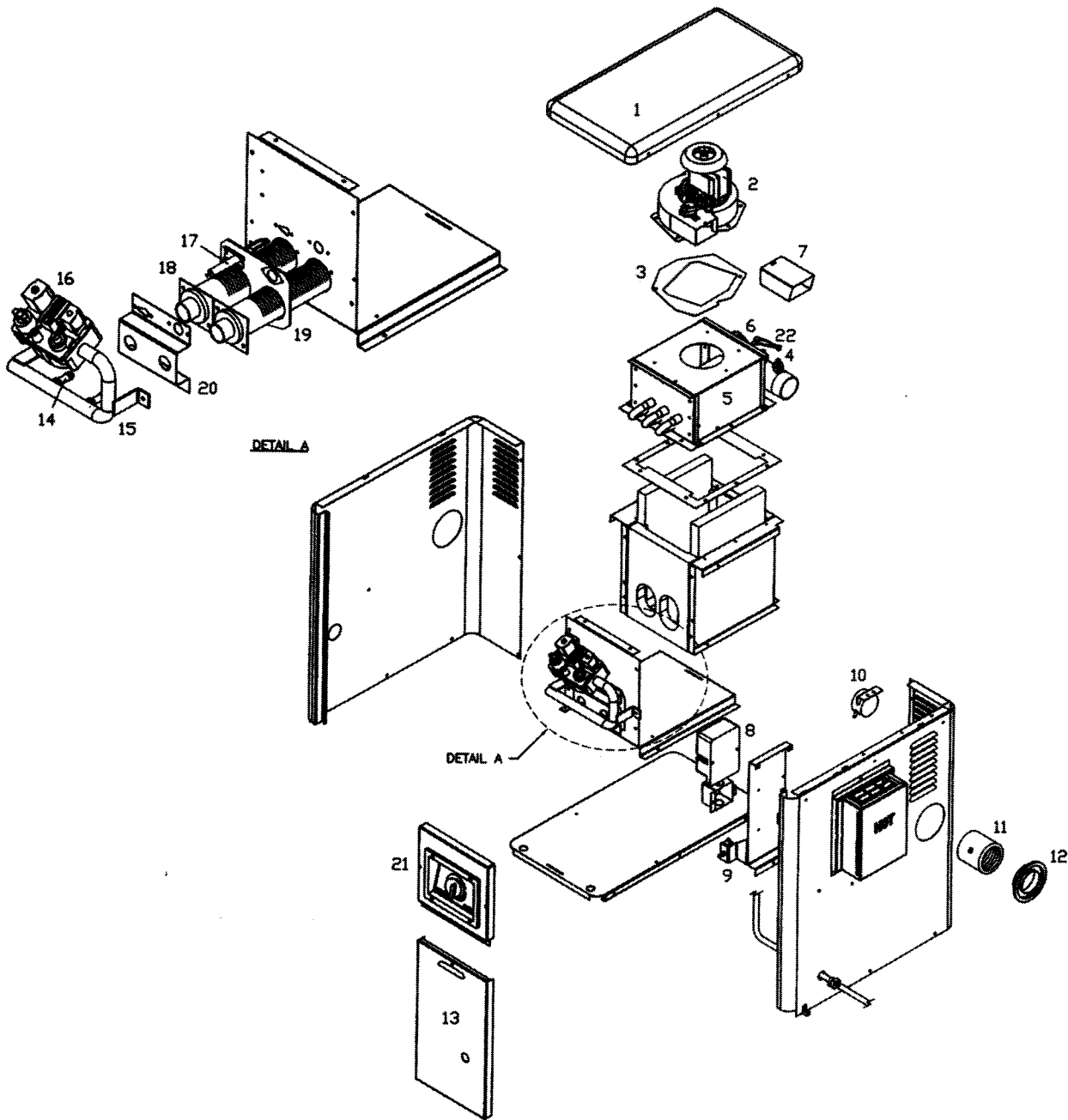

ITEM NO.	DESCRIPTION	PART NO.	ITEM NO.	DESCRIPTION	PART NO.
1.	Jacket, Top	IDX JKT 1100	12.	Grommet 1½" Pipe	IDX GRM 0001
2.	Combustion Blower (Jakel→Jakel)	IDX BWR 1930	13.	Front Access Door	IDX FAD 1101
	Combustion Blower (Jakel→Fasco conversion)	IDX BWR 1931	14.	Burner Orifice, Natural Gas	IDX ORF 1933
	Combustion Blower (Fasco→Fasco)	IDX BWR 1932	15.	Gas Manifold	IDX MAN 1100
3.	Blower Gasket (Jakel only)	IDX BLG 1930	16.	Gas Valve	IDX VAL 1930
4.	High Limit Kit	IDX HLK 1930	17.	Ignitor with cable	IDX IGN 1930
5.	Heat Exchanger Assembly (dual tubes)	IDX HXA 1100	18.	Burner	IDX BNR 1930
5.	Heat Exchanger Assembly (single tube after 6/99)	IDX HXA 1101	19.	Burner Gasket	IDX BRG 1930
6.	Water Pressure Switch	CZX PRS 1105	20.	Air Orifice Bracket, Natural Gas	IDX AOB 1930
8.	Interlock Switch	IDX ILS 1930	20.	Air Orifice Bracket, Propane	IDX AOB 1931
9.	Control Module	IDX MOD 1930	21.	Control Panel Assembly	IDX CPA 1100
10.	Air Pressure Switch	IDX APS 1930	22.	Wire Harness	IDX WHA 1930
11.	Coupling	IDX CPG 1930	22.	Wire Harness (after 1/00)	IDX WHA 1931

The change from Jakel combustion blowers to Fasco was made for production starting in 1/07.

Hayward Pool Heater Certificate of Limited Warranty

Limited heater warranty:

TERMS AND COVERAGE: We warrant our pool heater to be free from defects in workmanship and materials under normal use and service. Pursuant to this warranty and subject to the Conditions and Exceptions indicated below:

1. We will replace (cost of freight, installation, cost of fuel, and service labor at user's expense) with the prevailing comparable model, or, at our option, repair any pool/spa heater that leaks under normal use and service within one year from the date of original installation for all users.
2. In addition, we will replace (cost of freight, installation, cost of fuel, and service labor at user's expense) or, at our option, repair any part or parts of the pool/spa heater which malfunctions under normal use and service within one year from the date of original installation for all users.

LIMITATION ON IMPLIED WARRANTIES: WE ARE NOT LIABLE FOR ANY CONSEQUENTIAL DAMAGES FOR BREACH OF ANY WRITTEN OR IMPLIED WARRANTY OF THIS PRODUCT. Implied warranties, including the WARRANTY of MERCHANTABILITY and all other implied warranties that may arise from course of dealing or usage of trade imposed on the sale of this heater under laws of the state are limited in duration to the term of one (1) year for all users. There are no warranties which extend beyond the description on the face hereof. We shall not in any event be held liable for any special, indirect, or consequential damages.

EXPENSE OF DELIVERY AND INSTALLATION: Each pool heater or replacement part to be furnished under this warranty shall be furnished at our nearest distribution center. We shall not pay, nor be responsible for shipping or delivery charges to the place of installation, nor for labor charges or other costs of removal or installation. Every defective heater or part replaced under this warranty shall become our property, and as such, must be returned to our distribution center with transportation charges paid by the user. Any replacement pool heater furnished under this warranty shall remain in warranty only for the unexpired portion of this warranty.

CONDITIONS AND EXCEPTIONS: This warranty applies only to the pool/spa at its original place of installation and only for the original owner. It does not apply if the pool heater is installed in violation of any applicable code or ordinance, or is not installed, operated and maintained in accordance with our instructions, or is misused, damaged by accident, weather, act of God, freezing, water void and/or excess pressure, altered or disconnected. It does not apply with respect to:

1. A heater not equipped with Certified C.S.A. limit controls or equivalent pressure relief valve.
2. A heater operated with settings in excess of, and/or with fuel not conforming to those shown on rating plate;
3. A heater on which the serial numbers have been altered, defaced, or removed.
4. Leaks arising from defective installation;
5. Production of noise, odors, or discolored (rusty, etc.) water;
6. Leakage substantially contributed to by sediment, lime precipitate and/or higher than normal dissolved solids (pH above 7.8) in the tank, copper tubes, or water ways;
7. Leakage caused substantially contributed to by corrosive elements in the atmosphere (such as the storage of chlorine or other chemicals);
8. Leakage caused substantially or contributed to by corrosive pool water in an acid condition (pH below 7.2);
9. Damage caused substantially or contributed to by an external source of energy;

10. A pool/spa heater is a water containing device. Leakage of water from this device can be expected at some time due to malfunction or the limitations of the service life of various components. Do not install this product where such leakage can cause damage. MANUFACTURER IS NOT RESPONSIBLE OR LIABLE FOR ANY COSTS INCURRED BY SUCH DAMAGE.

IN NO CASE ARE WE TO BE HELD LIABLE FOR DAMAGE TO SURROUNDING AREA OR PROPERTY CAUSED BY LEAKAGE OR MALFUNCTION.

HOW TO CLAIM UNDER THIS WARRANTY: The original owner, upon discovering the defect, must present the attached completed warranty claim card with proof of purchase either to the dealer or notify the Company in writing at either address:

Hayward Pool Products, Inc.
900 Fairmont Avenue
Elizabeth, NJ 07207

or
Hayward Pool Products, Inc.
2875 Pomona Boulevard
Pomona, CA 91768

Upon receipt of such notification we shall decide whether to repair such parts or replace any pool heater, reserving at all times the right to inspect in order to verify any claimed defect. We also reserve the right to have our representatives make any inspections, repairs, or to furnish replacements. This warranty is intended as a legally binding obligation of the Company, enforceable in the courts. This warranty may give you specific legal rights which may vary from state to state.

LIMITATION ON LIABILITY: All intended representations have been expressly set forth in this document. This warranty may not be extended by oral or any other additional representations, written sales information, drawings, or other malfunction, is strictly limited to repair or replacement of the defective heater or part, as provided herein and the Company is not responsible hereunder for incidental or consequential or incidental costs or damages. The company neither assumes, nor authorizes any person or firm to assume for us, any further liability or obligation in connection with the sale, installation, use, maintenance, or existence of the heater.

SAFETY WARNING: Pool heaters are heat producing appliances and to avoid damage or injury in the event of possible overheating of the outer jacket (1) no materials should be stored against the jacket and (2) care should be taken to avoid unnecessary contact (especially by children) with the jacket. When lighting a gas heater, the lighting instructions must be followed exactly to prevent "flash-back" of excess gas in the heater. Electronic ignition heaters and electric heaters must have the power shut off when making adjustments to, servicing, or coming into contact with the heater. UNDER NO CIRCUMSTANCES SHOULD FLAMMABLE MATERIALS, SUCH AS GASOLINE OR PAINT THINNERS, BE USED OR STORED IN THE VICINITY OF THE HEATER OR IN ANY LOCATION FROM WHICH FUMES COULD REACH THE HEATER. For your comfort, enjoyment and safety, please read the enclosed operating instructions carefully.

FireTile™ five year limited warranty:

TERMS AND COVERAGE: This warranty is an extended warranty applicable to the FireTile™ components used in the conditions, limitations, and exceptions of the regular pool heater limited warranty remain in force, apply to this warranty, and are incorporated herein by reference.

Under the terms of this special FireTile™ limited warranty, we will replace (cost of freight, installation, cost of fuel, and service labor at user's expense) any components of your pool/spa heater made of FireTile™ which fail from defects in workmanship and materials under normal use and service in a single family residential application for a period of five (5) years.

USE THIS FORM ONLY FOR MAKING A CLAIM

LIMITED 1 YEAR POOL/SPA/HOT TUB HEATER CLAIM FORM

Model No. _____ Serial No. _____
 Purchaser's Name _____
 Installation Address _____
 City/State/Zip _____
 Single Family Residential Use Yes No If no, fill in use _____
 Dealer's Name _____
 Address _____
 Date of Installation _____

Note to Dealer: Fill in the following information on replacement heater.

Model No. _____ Serial No. _____ Date Installed _____



HAYWARD POOL PRODUCTS, INC.

Hayward Pool Products, Inc.
900 Fairmount Avenue
Elizabeth, NJ 07207

Hayward Pool Products, Inc.
2875 Pomona Boulevard
Pomona, CA 91768

Hayward Pool Products, Inc.
2880 Plymouth Drive
Oakville, Ontario L6H 5R4

Hayward S.A.
Zoning de Jumet
B6040 Jumet, Belgium