

# RANGER 2 POOL LIFT

**\*MEASUREMENT TAKEN WITH THE LIFT AT FULL LOAD**

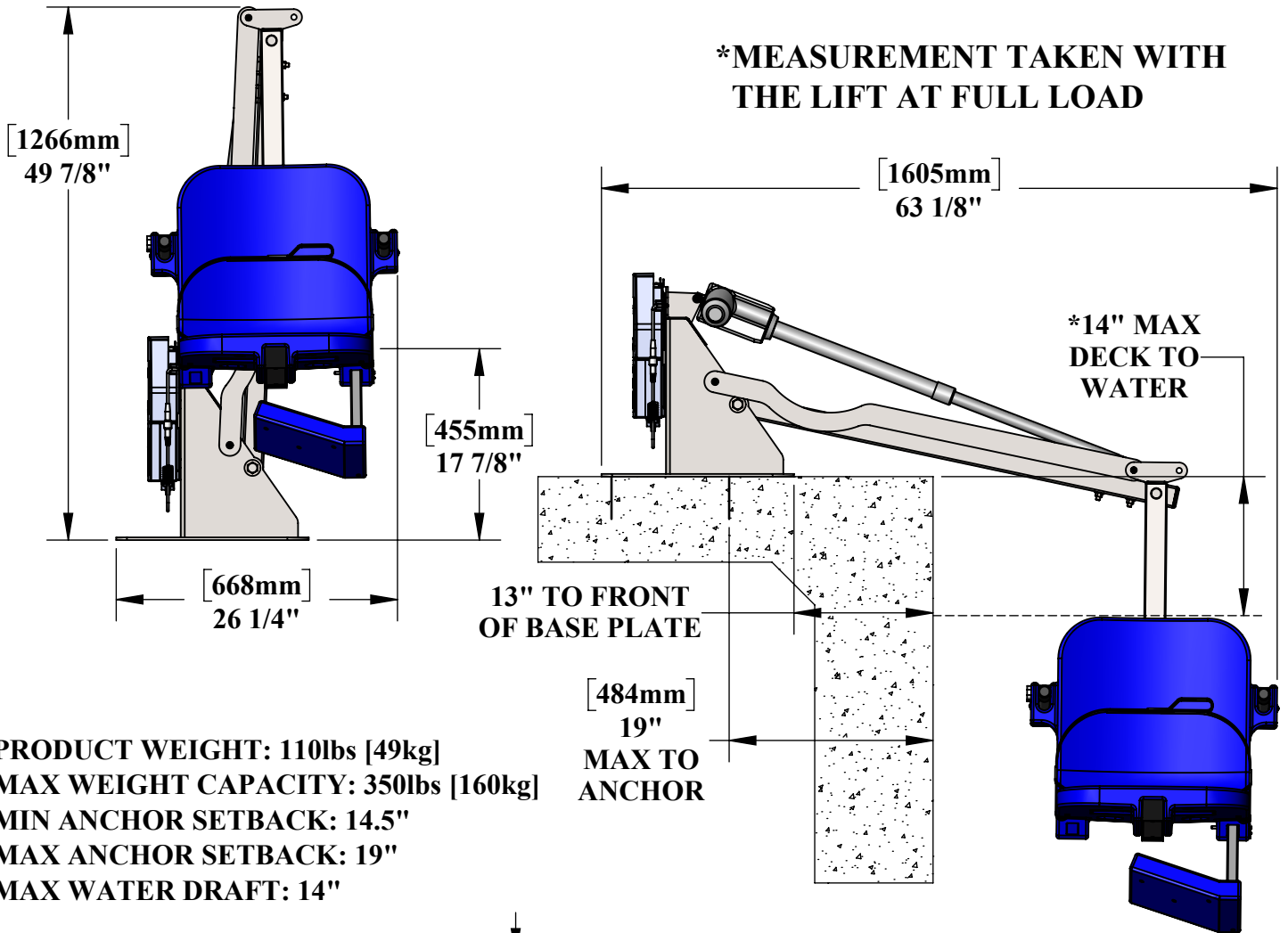

**PRODUCT WEIGHT: 110lbs [49kg]**  
**MAX WEIGHT CAPACITY: 350lbs [160kg]**  
**MIN ANCHOR SETBACK: 14.5"**  
**MAX ANCHOR SETBACK: 19"**  
**MAX WATER DRAFT: 14"**

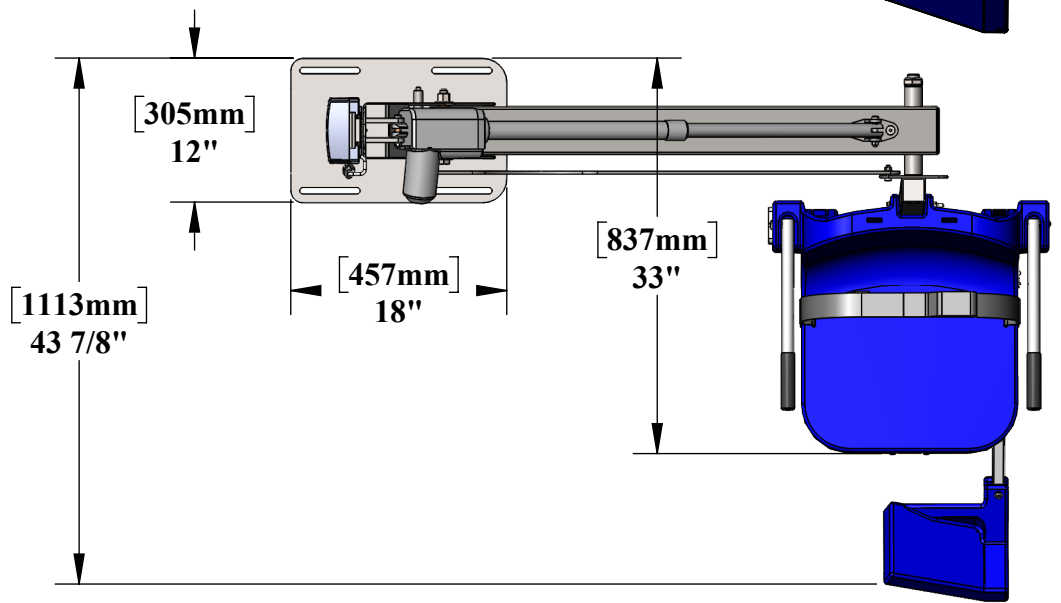

9889 GARRYMORE LANE  
 MISSOULA, MT 59808  
 (406) 549-0769  
 FAX (406) 549-2602

NOTE:  
 \*SPECIFICATIONS ARE SUBJECT TO CHANGE WITHOUT NOTICE

PRODUCT:		RANGER 2	
PART #:		F-RNGR2	
SCALE:	1:16	DATE:	1/17/2019
DRAWN BY:	KR	REVISION:	A