



Spring Grove, Illinois 60081
www.intermatic.com

COMBOConnect™ Junction Box Transformer

Model PJBX52100

Installation and operation manual

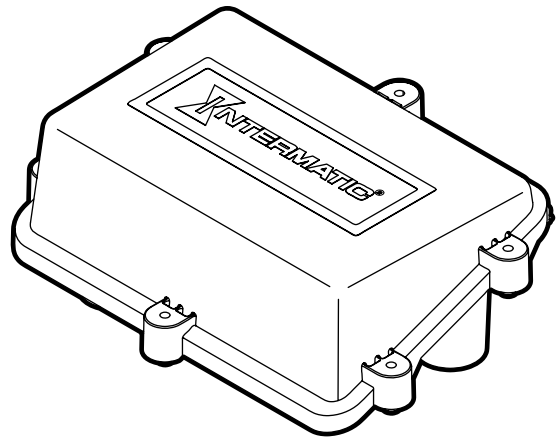

SAFETY SECTION

⚠ Warning

Risk of Fire or Electric Shock

• For outdoor use only. Mount at 12 in. (30 cm) (measured from the inside of the bottom of the enclosure) above ground or pool deck, or not less than 8 in. above the maximum pool water level, whichever provides the greater elevation.

- Disconnect power at the circuit breaker(s) or disconnect switch(es) before installing or servicing. More than one circuit breaker or disconnect may be required to de-energize the equipment for servicing.
- Installation and/or wiring must be in accordance with Article 680 of the National Electrical Code, Section 68 of the Canadian Electrical Code, and with all other applicable national and local code requirements.
- Use only copper conductors rated at least 90 °C for all connections.
- Keep cover on at all times when not servicing.
- Use water-resistant, flexible cord: 18/2 STW, 18/2 STOW, 18/2 SJTW, 16/2 SJTW, 16/2 STW, 14/2 SJTW, 14/2 STW for all load connections.
- Use duct-seal to seal around the cord.
- Insert provided plugs into all unused openings.
- For Canada installations, install power unit 5 ft. (1.5 m) or more from pool or spa and 10 ft. (3.05 m) or more from a fountain. Where the power unit is installed within 10 ft. (3.05 m) of a pool or spa, connect power unit to a GFCI protected circuit branch
- INSTALLER: Run the branch circuit grounding conductor to the equipment grounding conductor terminal of the panel board. The terminal must be directly connected to the panel board enclosure.

PRODUCT DESCRIPTION

The COMBOConnect™ Junction Box Transformer (PJBX52100) provides a safe, reliable connection for up to five low-voltage pool, spa, or landscape luminaires. The polymeric, watertight junction box has a built-in 100 W safety transformer that supplies 12 VAC or 13 VAC of power.

Specifications

Input Voltage	120 VAC
Input Amperage	1 A Maximum
Frequency	60 Hz
Input Ports	2
Output Voltage	12 VAC or 13 VAC
Output Ports	5

Lamp Wattage	100 W Maximum
Maximum Wire Gauge	4 AWG, solid or stranded
Minimum Wire Gauge	18 AWG
Dimensions	11-3/4" L x 8-1/2" W x 4-1/4" H
Terminal screw torque settings	4-6 AWG: 35 in/lb 8 AWG: 25 in/lb 10-18 AWG: 20 in/lb

PACKAGE CONTENTS

- (1) Junction Box Transformer
- (5) Conduit plugs
- (7) 1/2" - 3/4" Conduit reducer bushings

- (5) Cord strain relief
- (16) Cover and strain relief screws

Not included: Wall/Post Mounting Bracket (Model PA119)

INSTALLATION - JUNCTION BOX TRANSFORMER

Note: For low-voltage landscape lighting instructions, refer to "Installation - Low-Voltage Landscape Lighting" on page 6.

Mounting the Junction Box Transformer

1. Determine the appropriate location for the junction box transformer. See FIG. 1 for placement information.
2. Securely mount the junction box transformer using $\frac{3}{4}$ " rods. See FIG. 2 for rod mounting information.

Note: An optional wall/post mounting bracket (Model PA119) is available for post or wall mounting.

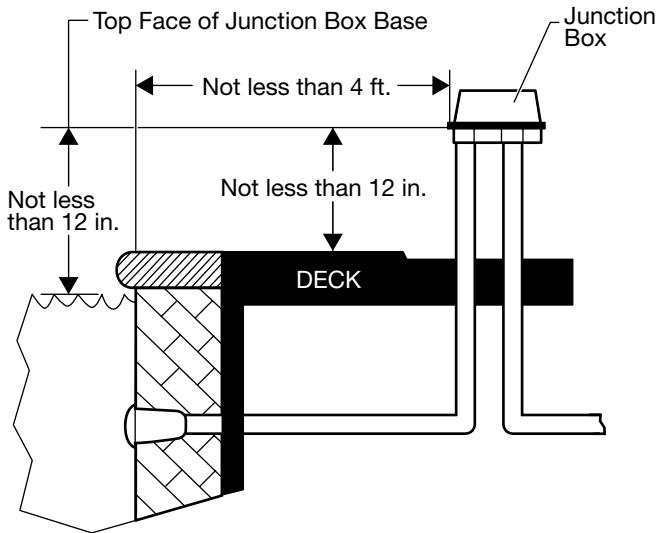

FIG. 1. Junction Box Transformer Placement

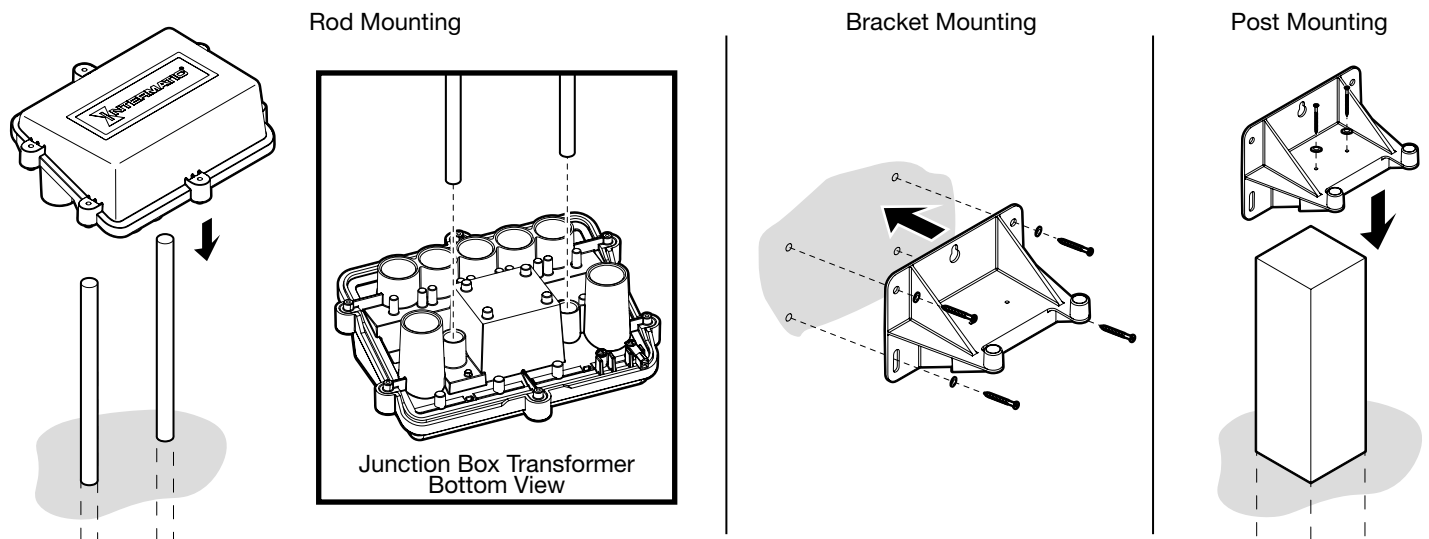

FIG. 2. Mounting Options

Wiring

Note: Only non-metallic conduit may be used when installing the PJBX52100.

1. Determine the appropriate non-metallic conduit size.
2. Determine the number of conduits needed for the installation.
3. Run the high-voltage and low-voltage non-metallic conduits to the junction box transformer. See FIG. 3 for the location of the conduit openings.
4. Fasten the conduit to the junction box transformer according to the conduit size being used:

Note: The PVC solvent cement bonds the conduit to the junction box transformer. Follow the manufacturer's instructions when applying PVC solvent cement. PVC solvent cement must be applied in accordance with the manufacturer's instructions, to ensure proper bonding.

- a. For 1" conduit (See FIG. 4):
 - Cut each conduit section being inserted into the junction box transformer to the same level.
 - Apply PVC solvent cement around the top 1" of the conduit in accordance with the PVC cement manufacturers instructions.
 - Apply PVC solvent cement around the inside diameter of the conduit opening.
 - Insert the conduit section into the junction box transformer conduit opening, until it reaches the stops.
 - Repeat the process for each conduit section until all of the needed conduit openings are filled.

- b. For ¾" conduit (See FIG. 5 and FIG. 6):
 - Break the tab off one of the included conduit reducer bushings.
 - Fasten the conduit reducer bushing for the ¾" conduit to the conduit opening:
 - » Apply PVC solvent cement around the inside diameter of the conduit opening.
 - » Apply PVC solvent cement around the outer circumference of the smaller opening of the conduit reducer bushing.
 - » Insert the conduit reducer bushing into the conduit opening, smaller opening first, up to the stops in the plastic.
 - Apply PVC solvent cement around the top 1" of the conduit in accordance with the PVC cement manufacturers instructions.

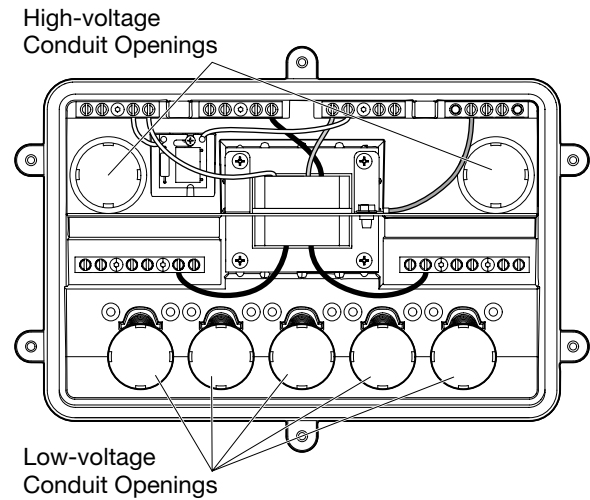

FIG. 3. Junction Box Transformer Conduit Openings

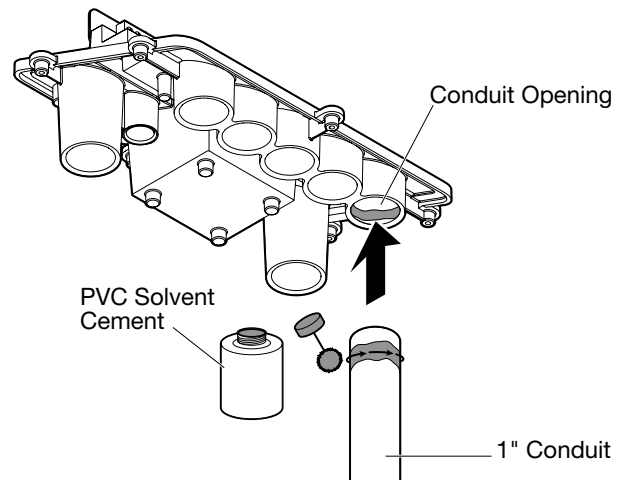

FIG. 4. Using 1" Conduit

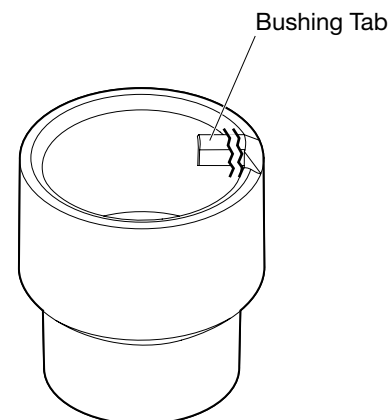

FIG. 5. Conduit Reducer Bushing Tab

- Apply PVC solvent cement around the inside diameter of the conduit reducer bushing.
- Insert the conduit into the conduit reducer bushing, until it reaches the stops.
- Repeat the process for each conduit section until all of the needed conduit openings are filled.

c. For 1/2" conduit (See FIG. 7):

- Fasten the conduit reducer bushing for the 1/2" conduit to the conduit opening:
 - » Apply PVC solvent cement around the inside diameter of the conduit opening.
 - » Apply PVC solvent cement around the outer circumference of the larger opening of the conduit reducer bushing.
 - » Insert the conduit reducer bushing into the conduit opening, larger opening first, up to the stops in the plastic.

- Apply PVC solvent cement around the top 1" of the conduit in accordance with the PVC cement manufacturers instructions.
- Apply PVC solvent cement around the inside diameter of the conduit reducer bushing.
- Insert the conduit into the conduit reducer bushing, until it reaches the stops.
- Repeat the process for each conduit section until all of the needed conduit openings are filled.

5. Connect the junction box transformer external bonding lug to the Equipotential Bonding Grid, if required per the local or national electric code.

Note: Read warnings in safety section before proceeding.

6. Pull the power supply conductors from the source to the junction box transformer. See FIG. 8 for the power input locations.

7. Make the wiring connections. See FIG. 8.

- Connect the ground wire to the ground terminal.
- Connect the neutral conductor to the "Neutral" terminal block.
- Connect the L1 (120 V) conductor to either the:
 - 120 V IN (A) for 12 V output, or
 - 120 V IN (B) for 13 V output.

Note: DO NOT connect to both the 120 V IN (A) & (B) terminal blocks at the same time.

- Torque the terminal screws to 20 in./lbs.

Note: The factory default connection for the noise filter circuit is from the "Neutral" terminal block to the "120 V IN (A)" terminal block for a 12 VAC output. If a 13 VAC output is needed, rewire the noise filter from the "120 V IN (A)" connection to the "120 V IN (B)" connection. See FIG. 8.

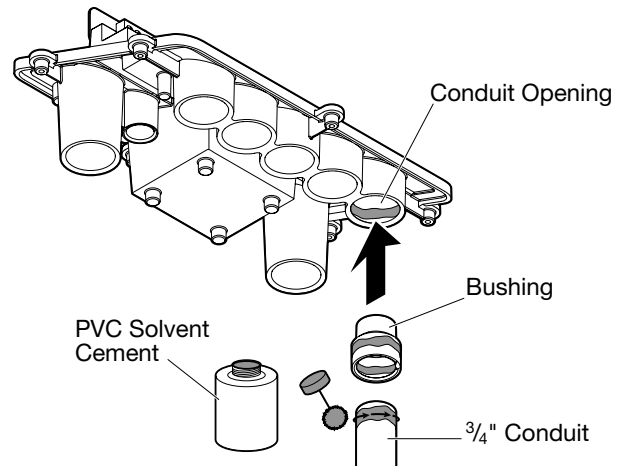

FIG. 6. Using 3/4" Conduit

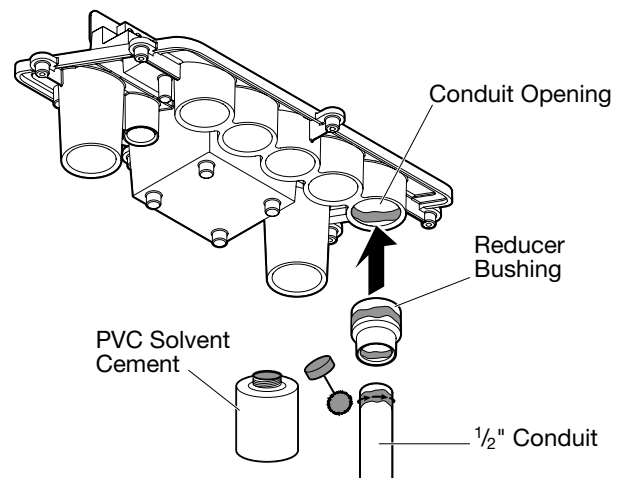

FIG. 7. Using 1/2" Conduit

Note: DO NOT connect to both the 120 V IN (A) & (B) terminal blocks at the same time.

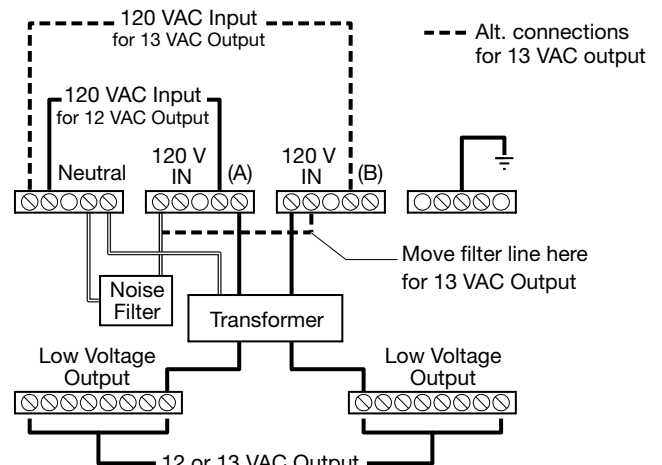

FIG. 8. Wiring Locations

8. Pull low-voltage cord(s) from the lamp(s) to the junction box transformer.
9. Connect the lamp cord(s) to the low-voltage output terminals. Torque the terminal screw for the connection to 20 in./lb.
10. Install the low-voltage cord strain relief(s). See FIG. 9:
 - The direction of the clamp is dependent on the diameter of the cable used:
 - For #16-2 and #18-2 cables, install the clamps with the arrow pointing down.
 - For #14-2 cable, install the clamps with the arrow pointing up.
 - Tighten the screws evenly until fully seated.
 - Repeat the process for all used low-voltage conduit openings.
11. After the wiring is complete, place duct-seal around the low-voltage cords at the conduit opening(s). The duct-seal must cover the conduit around the cord(s) to prevent any water from entering the junction box transformer.
12. Seal all unused conduit openings using the provided conduit plugs. See FIG. 10:
 - Apply PVC solvent cement, in accordance with the PVC cement manufacturer's instructions, around the circumference of the conduit plug.
 - Apply PVC solvent cement around the inside diameter of the conduit opening.
 - Insert the conduit plug until fully seated into the conduit opening.
 - Repeat the process for each conduit plug until all unused conduit openings are sealed.
13. Secure the cover using the six provided cover screws. Evenly tighten the screws until fully seated. Torque each screw to 19 in./lb. See FIG. 11.
14. Reconnect the power.

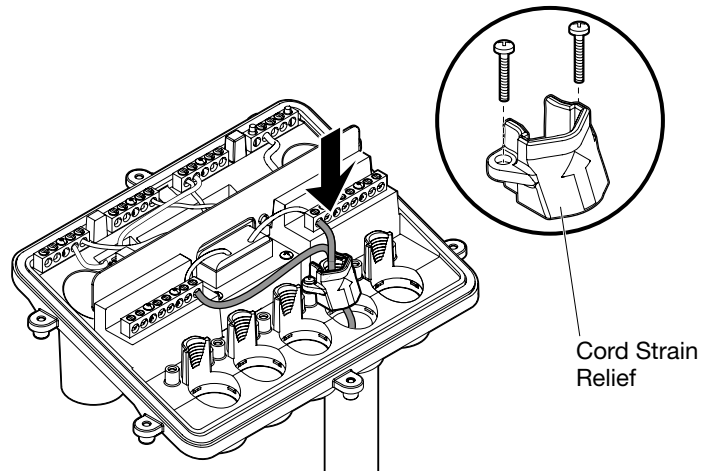

FIG. 9. Strain Relief Location(s)

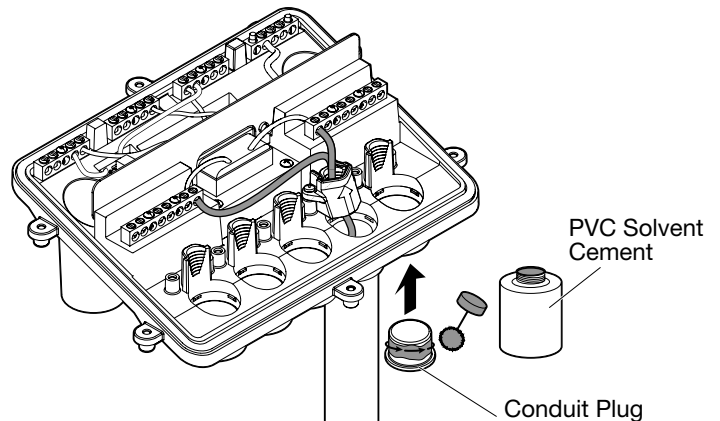

FIG. 10. Securing Conduit Plugs

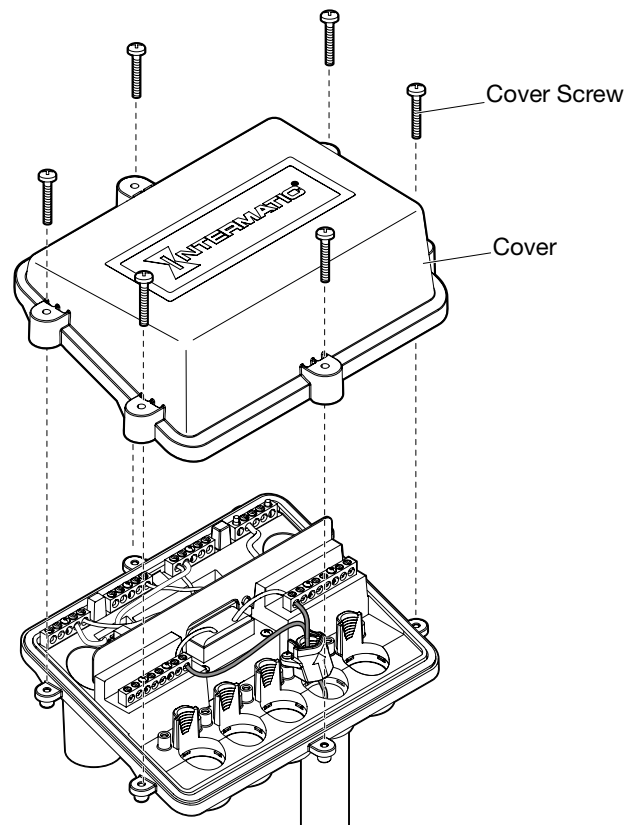

FIG. 11. Securing the Cover

INSTALLATION - LOW-VOLTAGE LANDSCAPE LIGHTING

Warning

Risk of Fire or Electric Shock

- Disconnect the power at the circuit breaker(s) or disconnect switch(es) before installing or servicing.
- More than one circuit breaker or disconnect may be required to de-energize the equipment for servicing.
- Installation and/or wiring must be in accordance with Article 680 of the National Electrical Code, section 68 of the Canadian Electrical Code, and with all other applicable national and local code requirements.
- Keep the cover on at all times when not servicing.
- For outdoor use only. Mount at 12" (30 cm) above ground.
- Suitable for use with a submersible luminaire.
- Use only copper conductors rated at least 90° for all connections.
- Install power unit 5 ft. (1.5 m) or more from pool or spa and 10 ft. (3.05 m) or more from a fountain. Where the power unit is installed within 10 ft (3.05 m) or a pool or spa, connect power unit to a GFCI protected circuit branch.
- For use on a branch circuit protected by a Class A Type Ground Fault Circuit Interrupter.
- For use with landscape lighting systems.
- This device is accepted as a component of a landscape lighting system where the suitability of the combination shall be determined by CSA or local inspection authorities having jurisdiction.
- Landscape lighting systems are for outdoor use only.
- Not for use in dwelling units.
- Low-voltage cables shall be buried a maximum of 6 in (15.2 cm) in order to connect to the main low-voltage cable.

For low-voltage landscape lighting:

1. To mount the junction box transformer, use one of the mounting configurations in "Mounting the Junction Box Transformer" on page 2.
2. To wire the junction box transformer, follow the installation wiring instructions, with the exception of the following:
 - Conduit is not required to be used when installing for low-voltage landscape lighting applications.
 - Duct-seal is not required when installing for low-voltage landscape lighting applications.
 - Strain relief is not required when installing for low-voltage landscape lighting applications.

WARRANTY

LIMITED ONE-YEAR WARRANTY

If within the warranty period specified, this product fails due to a defect in material or workmanship, Intermatic Incorporated will repair or replace it, at its sole option, free of charge. This warranty is extended to the original household purchaser only and is not transferable. This warranty does not apply to: (a) damage to units caused by accident, dropping or abuse in handling, acts of God or any negligent use; (b) units which have been subject to unauthorized repair, opened, taken apart or otherwise modified; (c) units not used in accordance with instructions; (d) damages exceeding the cost of the product; (e) sealed lamps and/or lamp bulbs, LED's and batteries; (f) the finish on any portion of the product, such as surface and/or weathering, as this is considered normal wear and tear; (g) transit damage, initial installation costs, removal costs, or reinstallation costs.

INTERMATIC INCORPORATED WILL NOT BE LIABLE FOR INCIDENTAL OR CONSEQUENTIAL DAMAGES. SOME STATES DO NOT ALLOW THE EXCLUSION OR LIMITATION OF INCIDENTAL OR CONSEQUENTIAL DAMAGES, SO THE ABOVE LIMITATION OR EXCLUSION MAY NOT APPLY TO YOU. THIS WARRANTY IS IN LIEU OF ALL OTHER EXPRESS OR IMPLIED WARRANTIES. ALL IMPLIED WARRANTIES, INCLUDING THE WARRANTY OF MERCHANTABILITY AND THE WARRANTY OF FITNESS FOR A PARTICULAR PURPOSE, ARE HEREBY MODIFIED TO EXIST ONLY AS CONTAINED IN THIS LIMITED WARRANTY, AND SHALL BE OF THE SAME DURATION AS THE WARRANTY PERIOD STATED ABOVE. SOME STATES DO NOT ALLOW LIMITATIONS ON THE DURATION OF AN IMPLIED WARRANTY, SO THE ABOVE LIMITATION MAY NOT APPLY TO YOU.

This warranty service is available by either (a) returning the product to the dealer from whom the unit was purchased or (b) completing a warranty claim online at www.intermatic.com. This warranty is made by: Intermatic Incorporated, Customer Service 7777 Winn Rd., Spring Grove, Illinois 60081-9698. For warranty service go to: <http://www.intermatic.com> or call 815-675-7000.

Because of our commitment to continuing research and improvements, Intermatic Incorporated reserves the right to make changes, without notice, in the specifications and material contained herein and shall not be responsible for any damages, direct or consequential, caused by reliance on the material presented.