

TALOS™ SFD-1000 Series

Patent Pending

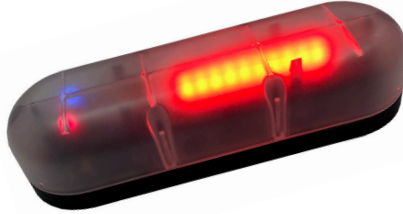

APPLICATIONS

- Golf Carts
- Swimming Pools
- Water Craft; Boats, Kayaks, Jet Ski's
- ATV's and Lawn Equipment
- Construction Sites & Equipment
- Bicycles and Motorcycles/Scooters
- The Beach
- Sporting Events / Sporting Equipment
- Baby Strollers

DESCRIPTION

The SFD-1000 series is a Storm Front Detector utilizing a proprietary patent-pending design for Storm Safety Awareness of Lightning Strikes in the area.

Over 6000 deaths and injuries occur from lightning strikes every year. The SFD-1000 can alert you to an approaching or departing storm front and lightning by sensing the distance of lightning strikes that are occurring in the area via audible and visual alerts, making you aware of potentially life-threatening situations.

FEATURES

- Up to 25 Mile Range
- Audible Beeper
- Compact Design
- 3 Different Colors Indicate the Distance (approaching or departing) of the Storm Front:
Green = 25 miles, Blue = 16 miles, Red = 6 miles
- Battery or hard-wired DC Power Options
- Low Cost
- High Accuracy
- IP-65 Waterproof
- OEM Tested and Approved
- Low power consumption
- Standard & Quick Disconnect Mountings

BATTERY & WIRED CONNECTIONS

Hard Wired Version:

Power Source	Function	Color
9-30 VDC	Supply V + Com	Red Black

Battery Version:

4 AA batteries (Lithium Batteries Recommended)

DIMENSIONS

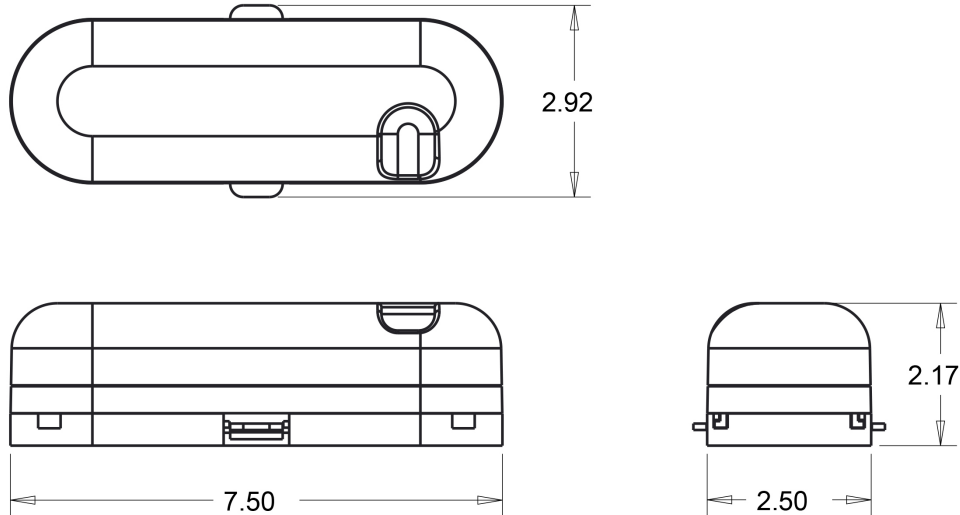

SPECIFICATIONS

Performance @ 25°C (77 °F)

Operating Temperatures
Reverse Polarity Protection

-20 to 80 ° C (-4 to 176 ° F)
Yes

Input

Supply Voltage: 9-30 VDC or
4 AA Batteries
(Lithium Recommended)

ORDERING

Series

SFD

Power Options

1000

Version

S

1000 = Battery Powered
1100 = Direct DC Source

S = Standard
G = Rugged (for higher shock applications)

*Consult factory for custom OEM options

Talos® is a registered trademark of Precision Measurement Technologies