

# SolarGuard

## ASSEMBLY INSTRUCTIONS Solar Cover Reel System (SG16, SG18 and SG20)

**PLEASE READ ENTIRE INSTRUCTIONS CAREFULLY BEFORE PROCEEDING**

### Four Easy Steps:

If you need additional assistance, call 905-876-4766 Monday to Friday 8:30 a.m. to 5:00 p.m. Eastern Time.

Before starting assembly, trim cover to clear the inside top edge of your pool. Recommended Solar Cover is 12 mil with round bubbles.  
Allow an extra 4" (10 cm) on cover length if installing the reel at mid-point or off-center.

### REEL SYSTEMS COMPONENTS AND PREPARATION:

#### Getting started:

Ensure that your system has two cartons consisting of one end carton and one tube set carton.

**Tools required for assembly:** Recommend Safety Glasses

- Portable drill
- Tape measure
- Pencil and Scissors

#### End Carton Parts List:

- 2 Wheels
- 2 Wheel Stops
- 2 Handles
- 2 Bearings
- 2 Plugs for tubes

- Hardware Kit: 10 Strap Plates  
10 Straps 10 Plastic Screws  
25 Self-drilling Stainless Steel Screws

**Tube Carton Parts List:**  
2 End tubes and 1 Center tube

### STEP 1: SOLAR REEL PLACEMENT

- A. Determine the best location for the reel system. *The widest point of the pool is the preferred locations (see Fig. 1 below). Small cover extensions may be folded in to avoid using a wider reel.*
- B. At the determined location, measure the width of the pool and add 6" (15 cm).

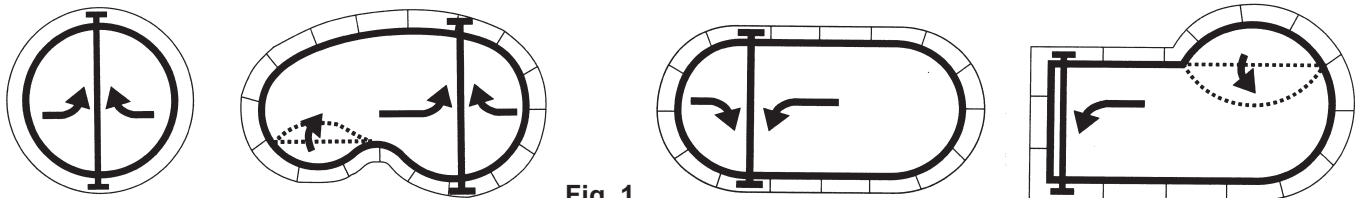

Above-Ground pools with deck

Fig. 1

### STEP 2: TUBESET ASSEMBLY

- A. Ensure minimum of each end tube is inside center tube (see table below right). Less than minimum insert causes screws to loosen and/or tubes to split.



Fig. 2

Insert both end tubes equal distance into center tube and mark on center tube where inner tubes end

Tube	Min. Insert	Max. Width	Max. Wet Cover Weight	Max. Cover
16'	9"	16'6" (4.9 m)	60# (27.3kg)	16x32
18'	9"	18'6" (5.7 m)	60# (27.3kg)	18x36
20'	12"	20'6" (6.3 m)	60# (27.3kg)	20x40

Mill tubes tarnish over time. This does not affect tube integrity.

## STEP 2: TUBE ASSEMBLY - (continued)

THIS STEP REQUIRES A TOTAL OF 12 SELF-DRILLING SCREWS **DO NOT** pre-drill holes or over-tighten screws.

B. Lock tubes together by rotating the center tube in the opposite direction to end tube. **HOLD TUBES LOCKED WHILE YOU INSTALL FIRST SELF-DRILLING SCREW ON A DRILL LINE**, 1" (2.5 cm) back from end of center tube at Location "C1" (see Fig. 3 & 4).

C. Place 2 more self-drilling screws at Location "C2" & "C3" - 1 screw at every second drill line around tubes (see Fig. 3).

D. At "D" locations install 3 screws around the center tube at every second drill line, 1" (2.5 cm) back from where you marked the end of the inner tube from Fig. 2A (see also Fig. 3).

E. Repeat for other end tube.

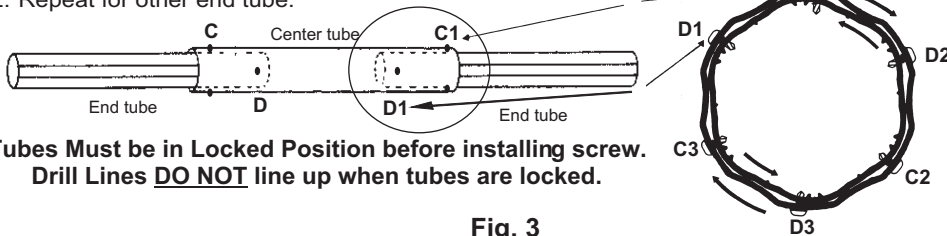

Fig. 3

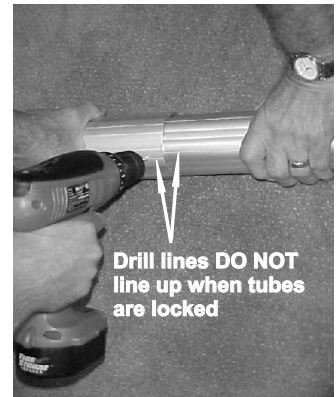

Fig. 4

**Tubes Must be in Locked Position before installing screw.**  
**Drill Lines DO NOT** line up when tubes are locked.

## STEP 3: ASSEMBLE ENDS

Assemble in numerical order (see Fig. 5)

- Insert Plug (#1) into End Tube.
- Place Bearing (#2) inside Wheel (#3).
- Push Handle (#4) through Bearing and into Plug.
- Insert 1 self-drilling screw (#5) through tube in line with bump on plug rim (long prong) and 1" (2.5 cm) from tube end. (see Fig. 6).
- Repeat for other end.

**IMPORTANT:**  
5. When ends are assembled insert screw through tube in line with bump on plug rim, 1" (2.5 cm) from tube end - at BOTH ends.



Fig. 6

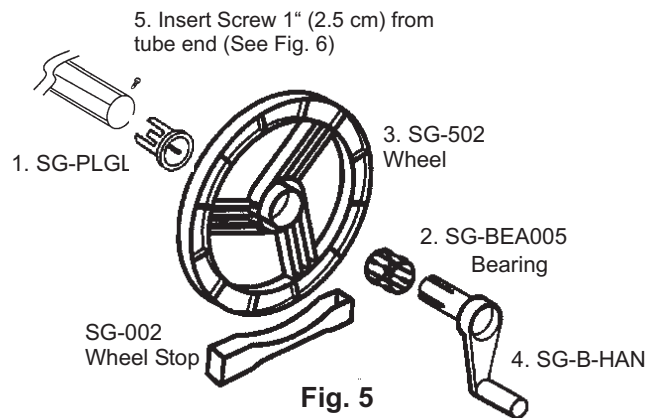

Fig. 5

## STEP 4: STRAP ATTACHMENT

**Attach a Strap Plate to one end of all Straps provided (see Fig. 8).**

Adjust strap length at Strap Plate if necessary.

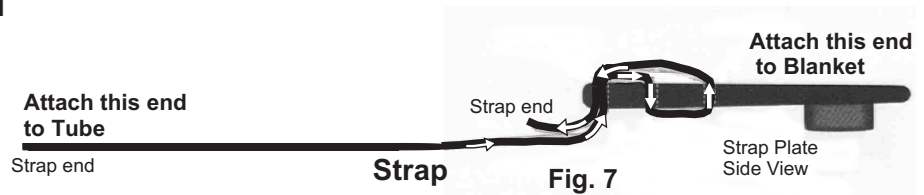
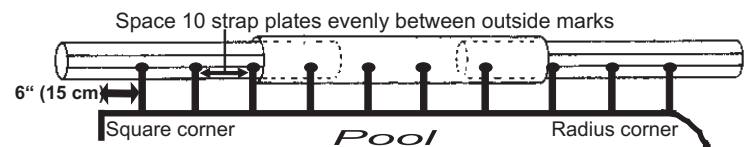

Fig. 7

## STRAP ATTACHMENT - TO TUBES

A. Mark each End Tube 6" (15 cm) in from the inside edge of pool top rail. The first 2 Straps will be attached at these outside marks on a Drill Line (see Fig. 9). The remainder of the Straps will be spaced evenly - on Drill Lines - between the outside 2 Straps. Mark all Strap locations beforehand. Use all Straps provided. Note: Maximum distance between straps is 30"

B. Attach Straps to Tubes at the marks with a Metal Screw directly through the strap material and approximately 1" back from the end of the strap (see Fig. 9). **DO NOT** pre-drill holes or over-tighten Screw.



First strap plate is placed 6" (15 cm) in from inside edge of pool or at start of radius corner. Place system across widest point of pool if radius corners are greater than 6".

Fig. 8

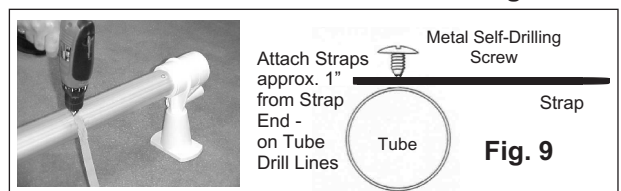
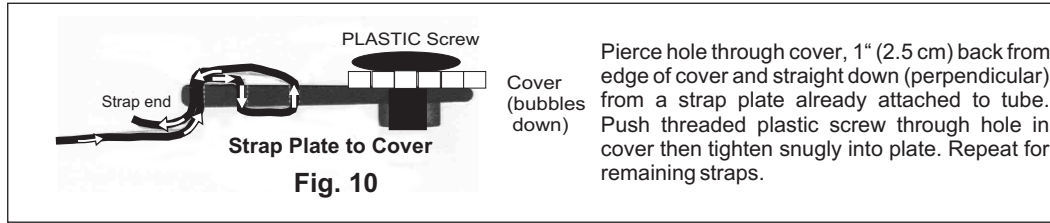

Fig. 9

## STRAP ATTACHMENT - TO COVER

D. Choose either Fig. 10 or Fig. 11 - the appropriate instructions below for your pool shape. If you have determined a mid-pool or off-center placement, it will be easier if you move the cover away from the pool and fold it (bubbles in) on a flat surface.

### For Systems Placed at Pool End (Rectangular Pools) (Fig.10)



### For Systems placed at Mid-Pool or Off-Center (Round, Oval or Irregularly Shaped Pools) (Fig. 11)

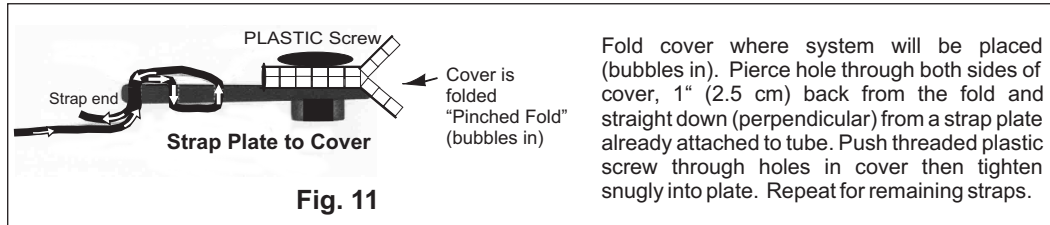

E. When you start to roll up the cover, all straps must take hold of the cover at the same time. Adjust the strap lengths at Strap Plate if necessary.

### Safe Use of Your Solar Reel:

Solar Reel systems are designed solely to remove solar covers and are not made to support people or any other weight.

Solar covers must be completely removed before entry into the pool. Under no circumstances, should one swim in a pool partially covered with the solar cover.

### Care and Storage:

**Check screws periodically and tighten, if necessary.** The solar reel may be stored outside for the winter. It is not recommended to disassemble it for storage

**In order to protect the warranty on your solar cover, it is essential to use a protective cover when the it is rolled up on the reel. In the summer use a White Sheet with UV inhibitors and in Winter, a Winter Jacket. If not provided, they can be purchased from your pool retailer.**



HV-WCR

### FeherGuard Accessories available through Pool Retailers:

FG-FASKIT	Tube & Blanket Fastening Kit (10 sets tube & blanket fasteners & 10 - 26" straps / package)
FG-PFS	Tube & Blanket Fasteners (10 sets / package)
FG-RS26	Reel Strapping (10 - 26" Straps / package)
FG-RS50	Reel Strapping (1 Roll 50' Strapping / package)
FG-MPR	Mid-Grip Pull Rope (helps pull Solar Blanket on to Pool - 35' Rope, 2 clips, 2 plates, 2 fasteners / package)
FG-WPS	White Protective Sheet with UV Inhibitors (Wrap to protect solar blanket on the reel 24' x 3 1/2' / package)
FG-BS2X6	Blanket Straps (secures rolled up Solar Blanket on Reel - 2 x 54" straps with buckles / package)

## One Year Warranty:

*SolarGuard* warrants for a period of one year from the date of delivery to the original consumer purchaser, that the *SolarGuard* solar cover reel system shall be free from defects in workmanship or material, under normal use and in accordance with *SolarGuard's* written installation and use instructions. *SolarGuard* at its option shall supply free of charge any part found to be defective in workmanship or material.

Any implied warranties are limited in duration to the one-year period from the date of delivery to the original consumer purchaser. **Excluded from this warranty are all consumables (bearings, straps, strap plates, screws). Tarnishing or discoloration of mill aluminum tubes can occur. This is not a warranty issue as tarnishing does not affect tube performance.**

This warranty is void if there is evidence of purchaser abuse, improper installation or normal wear.

*SolarGuard* will not be liable for incidental or consequential damages resulting from any defects in workmanship or material. Some States/Provinces/Countries do not allow the exclusion or limitation of incidental or consequential damages, so the foregoing limitations or exclusions may not apply.

This Warranty gives the claimant specific legal rights. The provisions of this Warranty are in addition to and not a modification of or a subtraction from the statutory warranties and other rights and remedies contained in applicable local legislation.

To validate Warranty, return this registration form within 30 days of purchase.  
Warranty claims should be processed through your Dealer and include your proof of purchase.

SolarGuard  
3153 Steeles Ave. West, Unit 5  
Milton, Ontario CANADA L9T 2V4

**Specifications subject to change without notice.**

01 16

**Thank you for buying the *SolarGuard* Solar Cover Reel System.  
We know it will make solar cover handling easy for you.**



### ***SolarGuard* "One Year" Warranty Registration**

Please Print

PURCHASER: \_\_\_\_\_

ADDRESS: \_\_\_\_\_ CITY: \_\_\_\_\_

STATE/PROVINCE/COUNTRY: \_\_\_\_\_ ZIP/POSTAL CODE: \_\_\_\_\_

SolarGuard

MODEL #

STORE LOCATION

PURCHASE DATE