

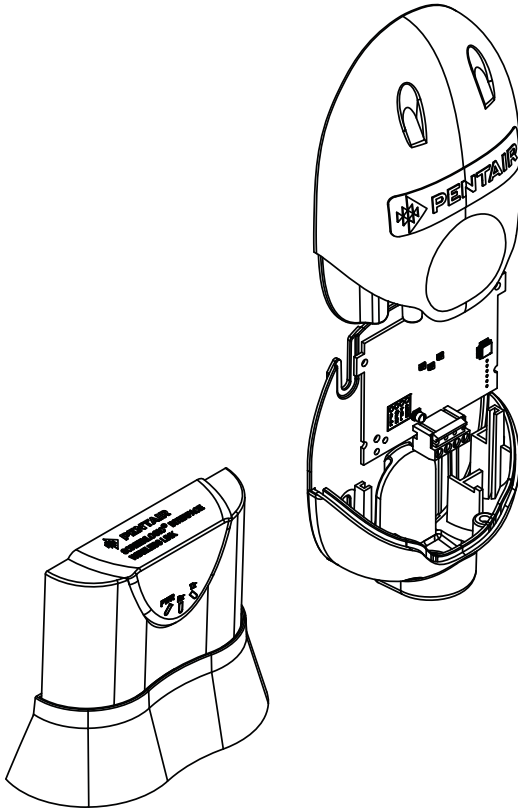

SCREENLOGIC® INTERFACE WIRELESS CONNECTION KIT FOR INTELLITOUCH® AND EASYTOUCH® CONTROL SYSTEMS



INSTALLATION GUIDE

IMPORTANT SAFETY INSTRUCTIONS
READ AND FOLLOW ALL INSTRUCTIONS
SAVE THESE INSTRUCTIONS

Technical Support

Phone: (800) 831-7133

Web sites: visit www.pentairpool.com and www.staritepool.com

Contents

Overview	1
Wireless Connection Kit Contents	1
Summary Installation Steps	2
ScreenLogic Interface Connection Diagram	3
Mount the Outdoor Wireless Transceiver and Connect to the IntelliTouch or EasyTouch Load Center	4
Connect the Indoor Wireless Transceiver to the ScreenLogic Interface Protocol Adapter	8
Connect the Indoor Wireless Transceiver to the ScreenLogic Interface Protocol Adapter	8
Cradle/Desk Mount the Indoor Wireless Transceiver	8
Wall Mount the Indoor Wireless Transceiver	8



FCC Regulatory Safety Notice

This equipment has been tested and found to comply with the limits for a Class B digital device, pursuant to Part 15 of the FCC Rules. These limits are designed to provide reasonable protection against harmful interference in a residential installation. This equipment generates, uses and can radiate radio frequency energy and, if not installed and used in accordance with the instructions, may cause harmful interference to radio communications. However, there is no guarantee that interference will not occur in a particular installation. If this equipment does cause harmful interference to radio or television reception, which can be determined by turning the equipment off and on, the user is encouraged to try to correct the interference by one or more of the following measures:

- Reorient or relocate the receiving antenna.
- Increase the separation between the equipment and receiver.
- Connect the equipment into an outlet on a circuit different from that to which the receiver is connected.
- Consult the dealer or an experienced radio/TV technician for help.
- Modifications not expressly approved by the party responsible for FCC compliance could void the user's authority to operate the equipment.

Notice: In order to comply with FCC RF Exposure requirements, a minimum separation distance of 8 in (20 cm) must be maintained between the equipment and all persons during normal operation.

Industry Canada Statement

The device complies with industry Canada's License Exempt RSSs. Operation is subject to the following: (1) This device may not cause interference; and (2) This device must accept interference that may cause undesired operation of the device.

Le dispositif est conforme à la licence d'Industrie Canada Exempt CNR. Le fonctionnement est soumis à la suivante. (1) Ce ne doit pas provoquer d'interférences ; et (2) Cet appareil doit accepter les interférences qui peuvent causer un mauvais fonctionnement de l'appareil.

This Class B digital apparatus complies with Canadian ICES-003. Cet appareil numérique de la classe B est conforme à la norme NMB-003 du Canada. The term "IC" before the certification / registration number only signifies that the Industry Canada technical specifications were met.

ScreenLogic® Interface Wireless Connection Kit Overview

The ScreenLogic® Interface Wireless Connection interface consists of an indoor and outdoor wireless 902-928 MHz wireless transceiver.

Note: The wireless transceivers ship from the factory as a matched pair.

The ID numbers on each transceiver must be the same number to function correctly. If needed, the transceivers are replaced as a matched pair. For more information, call Customer Support (880) 831.7133.

The indoor and outdoor transceivers provide a wireless connection between the ScreenLogic Interface Protocol adapter and the IntelliTouch® or EasyTouch® Control System Load Center located at the equipment pad. This wireless connection eliminates the existing hard wire connection from inside your home to the equipment pad.

In this Installation Guide

This Installation Guide provides installation instructions for the ScreenLogic® Interface Wireless Connection kit.

- For the ScreenLogic Interface system operating instructions, refer to the ScreenLogic Interface User's Guide (P/N 520493)

Wireless Connection Kit Contents

The following items are included in the Wireless Connection kit:

- One ScreenLogic Interface indoor wireless transceiver with AC power adapter and 1 ft. long cable with attached plugs.
- One ScreenLogic Interface outdoor wireless transceiver with 10 ft. cable, enclosure and mounting hardware.
- ScreenLogic Interface Wireless Connection Installation Guide (this manual).

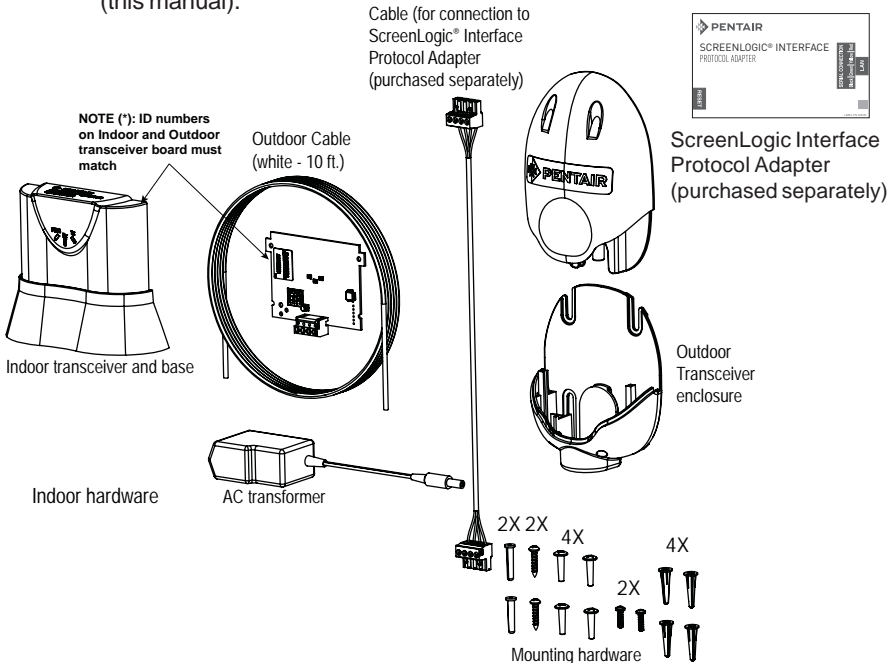

Summary Installation Steps

The ScreenLogic® Interface connection diagram on page 3 shows the transceiver locations and connections. To install the ScreenLogic Interface Wireless Connection kit:

- Mount the outdoor transceiver antenna module near the IntelliTouch® or EasyTouch® Control System Load Center (see page 4 for mounting instructions). Using the provided 10 ft. cable, connect the transceiver to the COM port connector located in the IntelliTouch or EasyTouch Control System Load Center (see page 7).
- Connect the ScreenLogic Interface indoor wireless transceiver to the ScreenLogic Interface Protocol adapter using the 12 in cable. Plug the AC power adapter into an AC wall-outlet and into the wireless transceiver unit to power up the unit (see page 8).

Note: ScreenLogic Interface Indoor Wireless Transceiver (Note: For optimum performance, mount indoor transceiver upright in the cradle or on an indoor wall).

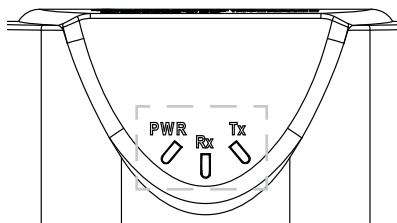

Indoor Wireless Transceiver

LED Indicators Description:

PWR: Green LED on: Power is on to the unit.

- **PWR LED blinking:** Not linked or lost link, attempting to link or relink, no response.
 - **PWR LED blinking, TX and/or RX LED blinking:** not linked, attempting to link, getting responses.
 - **PWR LED on steady:** Linked.
 - **PWR LED blinking:** Lost link, Attempting to relink.
- RX:** Yellow LED indicates the unit is receiving data.
TX: Green LED indicates the unit is transmitting data.

Antenna location

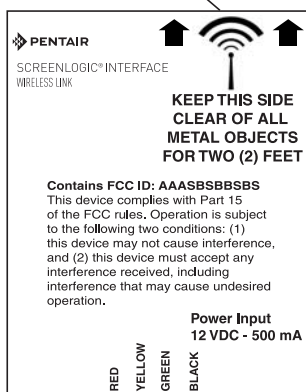

RS-485 Connector
(to Protocol Adapter)

IMPORTANT NOTICE: Be sure the yellow ID label (9-digit ID number XXXXXXXXX) located to the right of the RS-485 connector on the front side of the Indoor transceiver enclosure and the ID number on the ScreenLogic Interface Outdoor Wireless transceiver are the same. See page 1 for label location.

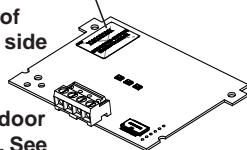

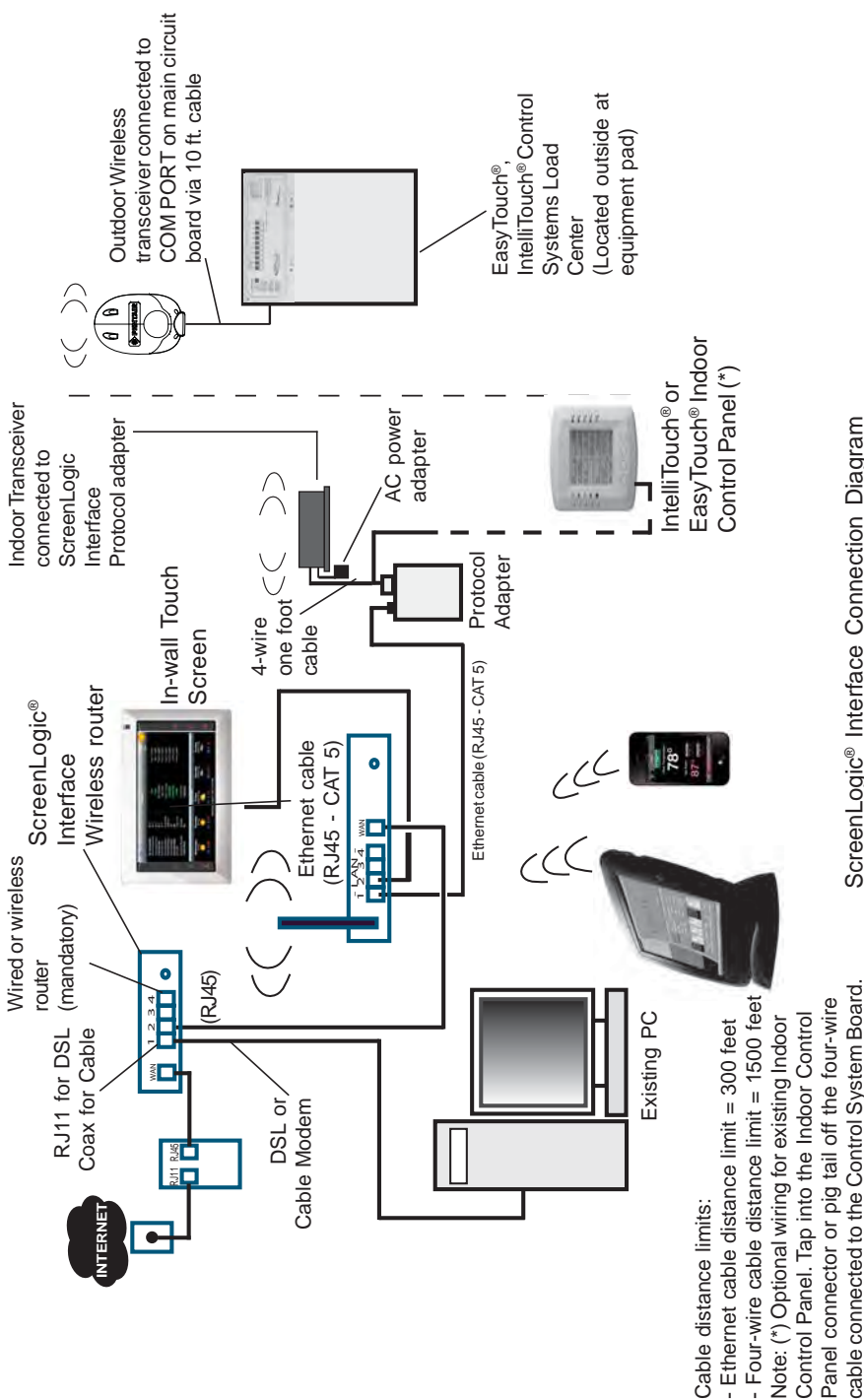

- Cable distance limits:
- Ethernet cable distance limit = 300 feet
 - Four-wire cable distance limit = 1500 feet
- Note: (*) Optional wiring for existing Indoor Control Panel. Tap into the Indoor Control Panel connector or pig tail off the four-wire cable connected to the Control System Board.

ScreenLogic® Interface Connection Diagram

Mount the Outdoor Wireless Transceiver and Connect to the IntelliTouch® or EasyTouch® Control System Load Center

The following describes how to mount and connect the outdoor transceiver to the IntelliTouch or EasyTouch Control System Load Center.

Mounting the Outdoor Transceiver Module

The outdoor transceiver is a two-way radio device with an attached antenna that communicates with the IntelliTouch or EasyTouch Control System via the 10 ft. four-conductor communication cable.

Outdoor transceiver mounting location: Choose a convenient location on a flat vertical surface near the Load Center at a minimum of 5 ft above ground level to optimize the transmit and receive operating range. For optimum performance position the Outdoor transceiver with an unobstructed line-of-sight propagation between the Indoor and Outdoor transceiver.

1. Position the back plate against the mounting surface so that the transceiver is oriented in an upright position with the antenna pointing upwards. Use a pencil to mark the four mounting points. Drill four 3/16 in. diameter holes into the mounting surface and insert the four plastic anchors provided in the kit.
Note: To avoid signal interference, mount the transceiver a minimum of 10 feet away from the load center, any metal surface/structure, or air blower located in the immediate area of the equipment pad.
2. Position the back plate over the mounting points and secure it with the four mounting screws provided in the kit.
3. Carefully position the transceiver circuit board into the mounted back plate. Route the communication cable wire up through the lower exit hole at the bottom of the back plate. Carefully pull the communication cable out the lower hole and position the circuit board in the back plate.
4. Proceed to **“Connect the wireless transceiver communication cable to the COM Port on automation control systems circuit board”** on page 6.
5. Slide the case over the circuit board and antenna into the back plate. Secure the circuit board in the case using the two retaining screws.

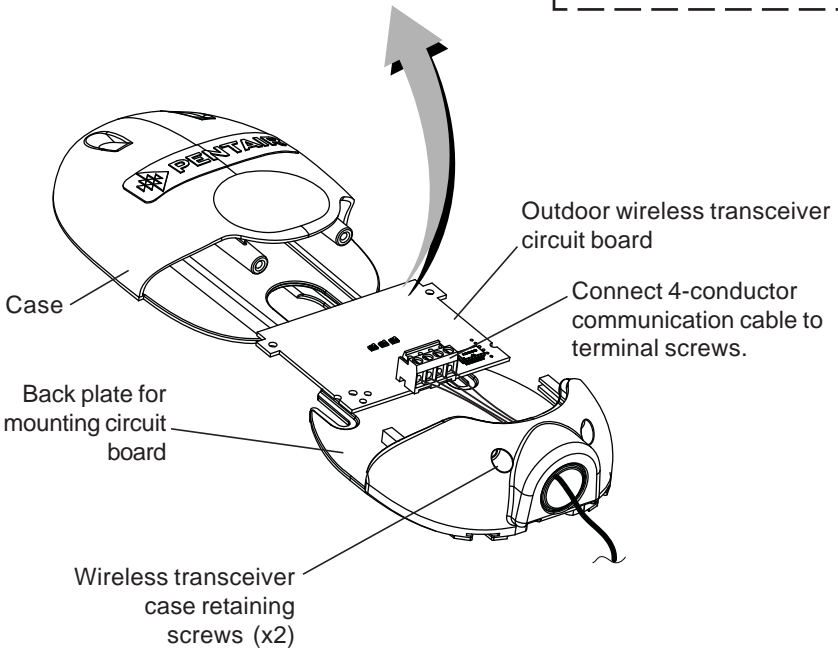
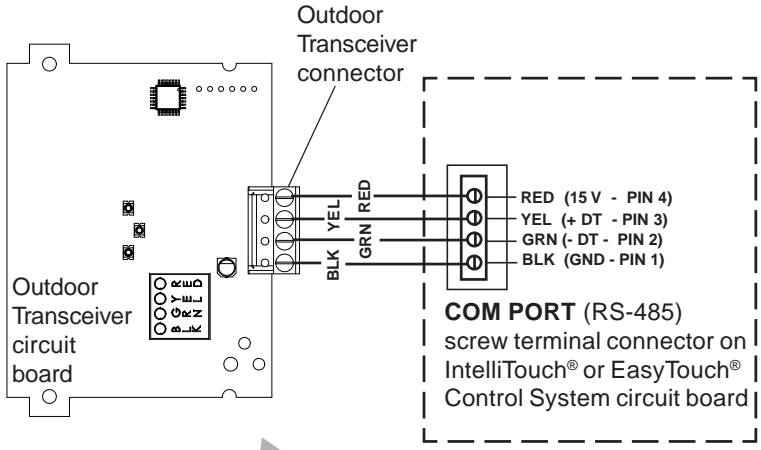

Outdoor Wireless Transceiver

Connect the wireless transceiver communication cable to the COM Port on automation control system circuit board

⚠ WARNING Switch OFF the main power to the Load Center before making any connections.

1. Switch OFF the AC power to the enclosure at the main house panel circuit breaker.
2. Unlatch the front door latch and open the front door. Remove the two retaining screws from the High-Voltage Cover Panel and remove the panel.
3. Loosen the two retaining screws securing from the top edge of the Outdoor Control Panel. Fold down the Outdoor Control Panel to access the circuit board sockets connectors for the electrical connections. Remove the panel from the enclosure (see illustration below).
4. Route the four conductor transceiver connection cable into the lower plastic grommet, up through the low voltage raceway to the system circuit board.

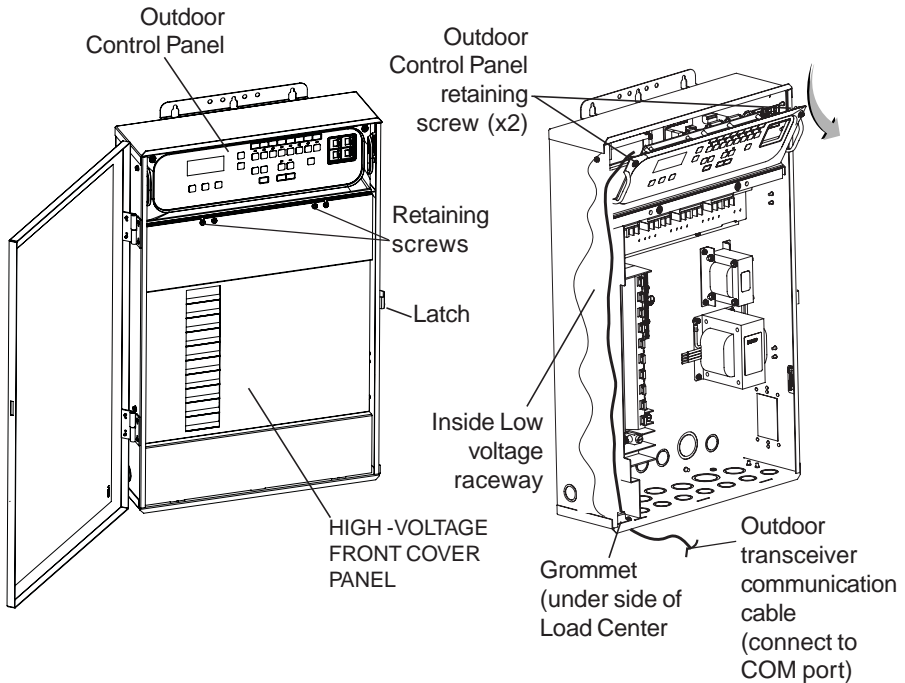

IntelliTouch® or EasyTouch® Control System Load Center

- Strip the leads of the communication cable wires back ¼ in. Insert the wires into the connector screw terminals. Using a small flat-blade screwdriver, secure the wires with the COM PORT (J7/J8) terminal screws. Note: Multiple wires may be inserted into a single screw terminal. Be sure to match the color-coding of the wires:

Pin 4 - Red = +15 VDC
Pin 3 - Yellow = +DT
Pin 2 - Green = -DT
Pin 1 - Black = GND

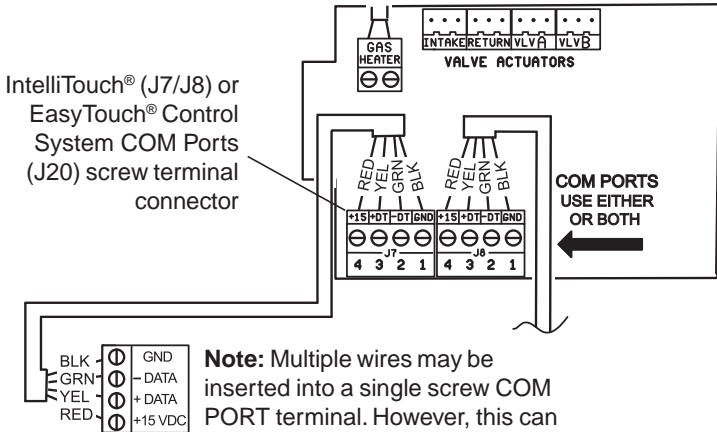

- After the communication cable connection has been completed; close the Outdoor Control Panel and tighten the two retaining screws. Reinstall the High Voltage Panel: Insert the panel's three tabs into the lower slots on the enclosure. Secure the panel with the two (2) retaining screws. Close the front door and secure it with the latch.
- Switch ON AC power to the Load Center.
- After the Power Center is powered up the Wireless Controller will automatically synchronize with the system and will be ready for operation. **Note: The initial connection can take up to 2-3 minutes.**
- Proceed to the "**Connecting the ScreenLogic Interface Indoor Wireless Transceiver to the ScreenLogic Interface Protocol Adapter**" on page 8.

Connect the Indoor Wireless Transceiver to the ScreenLogic® Interface Protocol Adapter

Connect the ScreenLogic Interface indoor wireless transceiver to the ScreenLogic Interface Protocol adapter as follow:

1. Using the 1 ft. connection cable, connect one end of the cable to the Protocol Adapter and the other end to the Indoor Wireless Transceiver. See Figure 1 and Figure 2. The cable plugs are keyed for easy connection.
2. Plug the 120 VAC Power Adapter into an AC grounded electrical outlet.

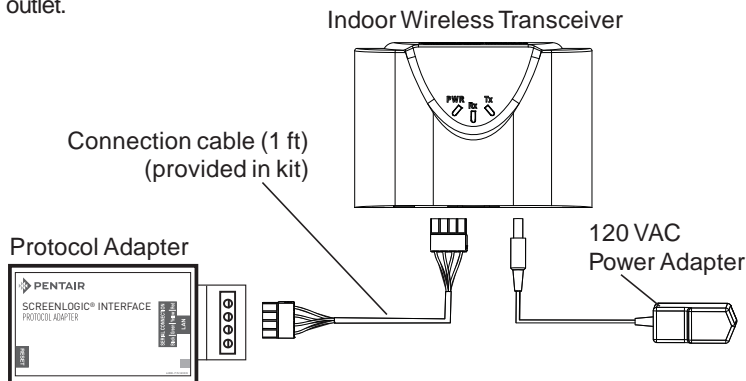

Connecting the Indoor Wireless Transceiver and Protocol Adapter

Cradle/Desk Mount the Indoor Wireless Module (Figure 1)

Mount the Indoor Wireless Transceiver in its cradle as follows:

1. Insert the power cable into the base of the Indoor transceiver cradle. Fasten the cable into the cradle slot (see Figure 1 on next page).
2. Insert the connection cable into the base of the Indoor transceiver cradle. Fasten the cable into the cradle slot (see Figure 1 on next page).
3. Place the cradle on a table or desk. Note: Keep the cradle and Indoor transceiver clear of all objects for two feet.

Wall Mount the Indoor Wireless Transceiver (Figure 2 and Figure 3)

Mount the Indoor Wireless Transceiver on an indoor wall as follows:

1. Cut out the wall mounting templating from the next page. Place the template on an indoor flat surface or wall and mark the two screw hole positions.
2. Drill two holes (0.223 in) 2-1/2 inches apart as shown on the template (see Figure 3 on next page).
3. Insert the wall plugs into both wall screw holes.
4. Insert the screws into the wall plug. Don't insert the screws all the way into the wall, leave about 1/16 in for the wireless transceiver to hang on the head of the screws (see Figure 2 on next page).
5. Mount the wireless transceiver onto both screw heads.

Wall Mount the Indoor Wireless Transceiver (Continued)

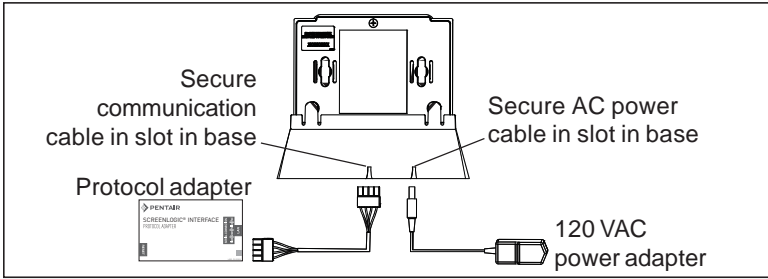

Figure 1: Cradle/Desk Mount the Indoor Wireless Transceiver

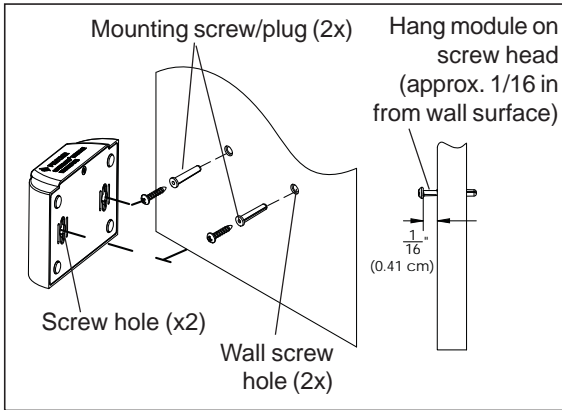

Figure 2: Wall Mount the Indoor Wireless Transceiver

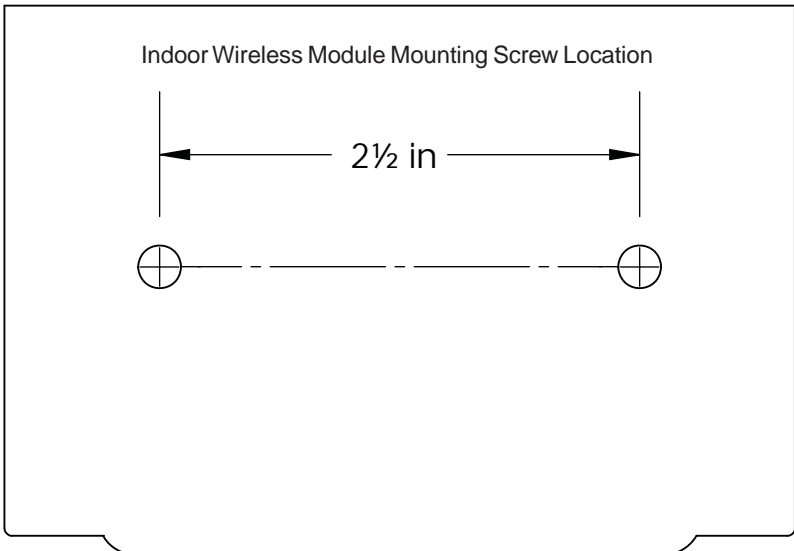

Figure 3: Wall Mount Template for Indoor Wireless Transceiver



1620 HAWKINS AVE., SANFORD, NC 27330 • (919) 566-8000
10951 WEST LOS ANGELES AVE., MOORPARK, CA 93021 • (805) 553-5000

WWW.PENTAIRPOOL.COM

All Pentair trademarks and logos are owned by Pentair or by one of its global affiliates. Pentair Aquatic Systems™, ScreenLogic®, EasyTouch® and IntelliTouch® are trademarks and/or registered trademarks of Pentair Water Pool and Spa, Inc. and/or its affiliated companies in the United States and/ or other countries. iPhone® is a registered trademark of Apple Corporation. Unless expressly noted, names and brands of third parties that may be used in this document are not used to indicate an affiliation or endorsement between the owners of these names and brands and Pentair Water Pool and Spa, Inc. Those names and brands may be the trademarks or registered trademarks of those third parties. Because we are continuously improving our products and services, Pentair reserves the right to change specifications without prior notice. Pentair is an equal opportunity employer.

© 2016 Pentair Water Pool and Spa, Inc. All rights reserved.
This document is subject to change without notice.



P/N 522633 REV. A 1/2016