

POOL FROG® XL PRO® Instruction Manual

Mineral Pool-Care Cyclers for Pools up to 40,000 Gallons



Cleaner

because it kills bacteria two ways

Clearer

because it helps keep pH in range

Softer

because it reduces chlorine use up to 50%*

Easier

with pre-filled pacs for no mess,
no guess and no stress



POOL FROG XL Pro comes with the POOL FROG Mineral Reservoir Patented Mineral Disinfectant

Customer Service 800-222-0169
frogproducts.com



WARNING

To minimize the risk of serious injury, death or damage, before installing or first using this equipment, read Instruction Manual and all safety labels and follow all safety instructions and precautions. Save manual for future reference.

TABLE OF CONTENTS

POOL FROG XL Pro Introduction	3
Notes and Safety Information	4
Safety Labels on Cyclers	5
Installation Tips to Ensure Proper Performance	6
In-Line Installation	7
Step 1: Preparing the Pool	8
Step 2: Putting the System to Work	9
Step 3: Setting the Cyclers Control Dials	10
Step 4: Routine Pool Care	11
Replacing POOL FROG Mineral Reservoir	12
Using FROG BAM®	13
Using POOL FROG Pac	14-15
Winterizing	15
Troubleshooting	16
Parts List	17
Maintenance - Replacing Control Dial O-Rings	18
Maintenance - Replacing Cap O-Rings and Knobs	19
Warranty	20

For information on King Technology's entire product line, visit our website at frogproducts.com

Welcome to easier pool care courtesy of POOL FROG XL Pro. With POOL FROG XL Pro, your pool water will look and feel better without a lot of work or a lot of chlorine. This system† controls bacteria using a combination of minerals and reduced chlorine levels-up to 50%* less.

Part 1
POOL FROG XL Pro Cyclers

The water treatment center that controls the flow of water to each part of the POOL FROG XL Pro System.



POOL FROG XL Pro Mineral Cycler For Pools up to 40,000 gallons. POOL FROG XL Pro Chlorine Cycler
Product #01-01-5450

Part 3
FROG BAM

Use with the POOL FROG XL Pro Mineral Cycler for a 90-day Algae-Protection Guarantee. One bottle is good for 15,000 gallons.
Product # 01-10-5060



There are 4 parts to the POOL FROG XL Pro System:

1. POOL FROG XL PRO Cyclers
2. POOL FROG Mineral Reservoir
3. FROG BAM 90-day Algae-Preventative
4. POOL FROG Pac

Part 2
POOL FROG Mineral Reservoir

Holds the minerals and fits inside the POOL FROG XL Pro Mineral Cycler. Product # 01-12-5462



Part 4
POOL FROGPac

Pre-filled with chlorine tablets and fits inside the POOL FROG XL Pro Chlorine Cycler.
Product # 01-03-5613



POOL FROG Mineral Reservoir comes inside POOL FROG XL Pro Mineral Cycler and is also sold separately.
POOL FROG Pac and FROG BAM sold separately.

†POOL FROG Mineral System consists of the FROG minerals silver chloride and carbonate used in conjunction with 0.5 ppm chlorine. The POOL FROG Mineral Reservoir must be used in conjunction with the POOL FROG Pac (EPA Reg. No.: 53735-2), an EPA registered chlorine pool product or a chlorine delivery device.
*Compared to the minimum EPA recommended chlorine level of 1.0 ppm for a stabilized swimming pool.

Notes and Safety Information

General Notes

These instructions contain information for the safe and proper operation of these Cyclers. Observe the following principles:

- Ensure that everyone using these Cyclers follows the instructions and safety precautions.
- Keep the instructions nearby and available for reference throughout the service life of these Cyclers.

These instructions do not provide for every possible contingency that might be encountered in connection with installation, operation or maintenance of this equipment. Should further information be desired or should particular issues arise which are not covered sufficiently in this manual, contact King Technology at 800-222-0169.





Explanation of the signal words

Signal words, which depict the probability and severity of harm, are used in these instructions. They are defined as follows:

Signal Word	Meaning
DANGER	Indicates an imminently hazardous situation which, if not avoided, will result in death, serious injury or major property damage.
WARNING	Indicates a hazardous situation which, if not avoided, could result in serious injury, death, or major property damage.
NOTICE	Indicates special instructions that are important but not related to physical injury hazards.

Explanation of the safety pictographs

The following pictographs illustrate the type of hazard.

Pictograph	Type of Danger
	Safety Alert/General Hazard
	Explosion Risk
	Hazardous Pressure
	Flammable Fire Hazard

Identification of warnings

Warnings are intended to help you recognize risks and avoid death, injury or property damage. This is how warnings are identified:

 Signal Word
Pictographs
<p>Description of danger. Consequences if ignored.</p> <p>⇒ The arrow signals a safety precaution to be taken to eliminate or reduce the risk.</p>

Safety Label on the POOL FROG XL Pro Cyclers

Review this label before installing or operating these Cyclers. Contact King Technology at 800-222-0169 if this label is missing from your POOL FROG XL PRO Cyclers.



Fire, explosion and high pressure hazards

To minimize the risk of serious injury, death or property damage while using the POOL FROG XL Pro Cyclers:

- ⇒ Read, understand and follow all instructions and safety precautions in the manual, and on this Cycler and on any label for chemicals used with these Cyclers including POOL FROG Pacs, POOL FROG Mineral Reservoir and FROG BAM Algae Preventative.

DANGER

- ⇒ Never use fast dissolving chlorine tablets, liquid bleach, or calcium hypochlorite in the POOL FROG XL Pro Cyclers.
- ⇒ Never mix Trichlor chlorine tablets with Calcium Hypochlorite, or with any other form of concentrated chlorine or other chemicals.
- ⇒ Never add any other types of chlorine, pH adjusters, shock treatments or algaecides through the skimmer. These products should be added directly into the pool if required.
- ⇒ Do not contaminate the POOL FROG XL Pro Cyclers, POOL FROG Mineral Reservoir, POOL FROG Pac or FROG BAM with dirt, organic matter, pool chemicals (such as calcium hypochlorite or pool shocks), fertilizers or other household chemicals. Contact between any of these substances and the POOL FROG XL Pro Cyclers, POOL FROG Mineral Reservoir, POOL FROG Pac or FROG BAM, will result in a chemical reaction with the generation of heat, liberation of hazardous gasses and fire or explosion.

WARNING

- ⇒ Use only POOL FROG Pacs, POOL FROG Mineral Reservoir, and FROG BAM in the POOL FROG XL Pro Cyclers. Never use bulk chemicals.
- ⇒ To prevent the build up of gas pressure in the POOL FROG XL Pro Cyclers, be sure the pool return line valves are open - except when opening or servicing the unit.
- ⇒ Do not inhale fumes from the POOL FROG XL Pro Cyclers or POOL FROG Pacs.
- ⇒ Avoid sparks, smoking, or any open flame near POOL FROG XL Pro Cyclers or chemicals.
- ⇒ Do not exceed maximum operating pressure of 50 psi or maximum temperature of 104° F.
- ⇒ Do not remove the cap while under pressure. Always turn off pump and bleed off pressure before opening POOL FROG XL Pro Cyclers.
- ⇒ Do not install automatic or fast shut off valves downstream of POOL FROG XL Pro Cyclers.
- ⇒ Always install the POOL FROG XL Pro Cyclers AFTER a heater (if applicable) on the return line.
- ⇒ Always install any additional sanitizing equipment AFTER and NEVER BEFORE the POOL FROG XL Pro Cyclers are installed on the return line.
- ⇒ Do not permit children to use or climb on this product. This product must be positioned to prevent children from using it as a means of access to the pool.
- ⇒ Always stand clear of the POOL FROG XL Pro Cyclers during pump start-up.
- ⇒ Replace POOL FROG XL Pro Cyclers if you see signs of cracks, damage or degradation to the Cycler bodies or caps.

NOTICE

- ⇒ Prior to pressurizing, check with your dealer to ensure your plumbing connections meet building codes.
- ⇒ Failure to properly winterize your POOL FROG XL Pro Cyclers could result in freeze damage. (See page 15 for winterizing details.)

Installation Tips to Ensure Proper Performance

Before installing, read all directions carefully and contact your dealer for installation support



WARNING

- Do not exceed maximum operating pressure of 50 psi.
- Do not install automatic or fast shut off valves downstream of Cyclers.
- Always install the POOL FROG XL Pro Cyclers AFTER the heater (if applicable) on the return line.
- Always install any additional sanitizing equipment AFTER and NEVER BEFORE the POOL FROG XL Pro Cyclers are installed on the return line.

1) If using a multi-speed pump, run pump for at least 6 hours per day at high speed (at least 40 gpm).

If the pump will run on low speed 24 hours per day or less than 6 hours per day on high speed, you must bleed the air while the pump is on by unscrewing both Cycler cap knobs until water appears from both Cyclers. Then screw the knob back on. Repeat this process each time the cap is removed for any reason.

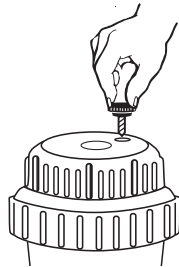

2) Install Cyclers with 4-8 psi back pressure.

Lower back pressures could result in under chlorination. Change the eyeball fittings in the return jets to a smaller size to increase back pressure. Contact King Technology at 800-222-0169 for a specially designed Cycler pressure gauge to determine back pressure at pool start-up.

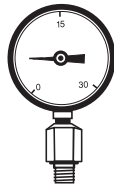

PN #01-22-4000

3) Special Installation Requirements:

IMPORTANT: Over chlorination or damage to the POOL FROG XL Pro Cyclers or other equipment could result if special installations A, B or C are not used in these situations.

- If water flow is higher than 80 gallons per minute (gpm), see diagram A.
- If an in-floor cleaner is included with pool, see diagram B, with two options. Preferred installation is Option 1 with two separate lines.
- If set-up is a pool and spa combination with common equipment, see diagram C.

Questions? Call Customer Service at 800-222-0169 Monday thru Friday, 8 am to 5 pm central standard time.

A. With High Flow Rate (greater than 80 gpm)

Install T-fittings exactly as shown.

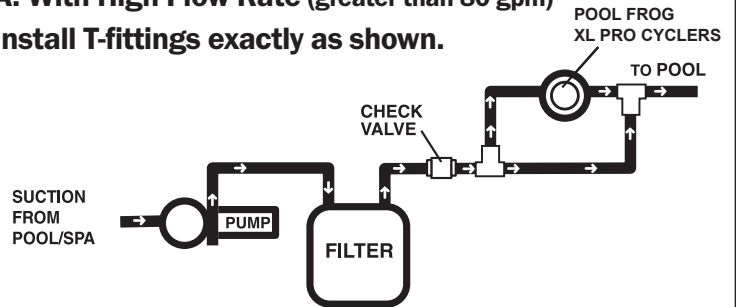

B. With In-Floor Cleaner - TWO OPTIONS

OPTION 1 - A Two-Line Installation

The best option is to have two lines. One line with pump, filter, heater and POOL FROG XL Pro Cyclers and a second line with a separate pump for the in-floor cleaning system (filter optional).

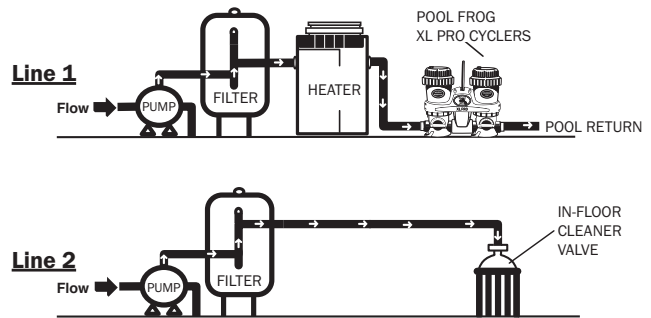

OPTION 2 - A 3-Way Valve Installation

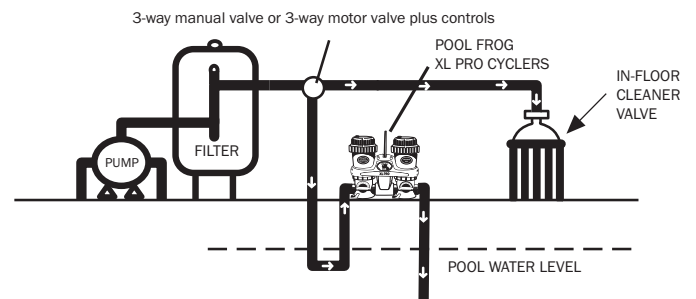

C. Pool and Spillover Spa Combination

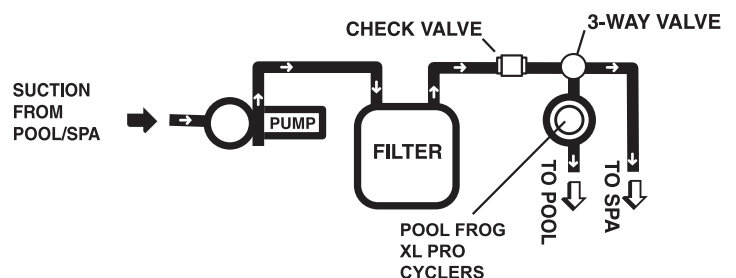

TOOLS NEEDED

Hacksaw

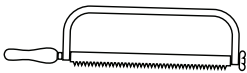

Tape Measure



MATERIALS NEEDED

Primer and PVC Cement

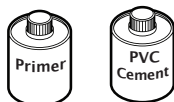

SECURE CYCLERS

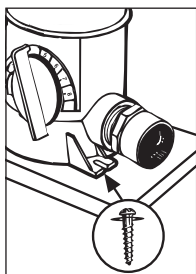

For better stability, POOL FROG XL Pro Cyclers may be mounted on a treated wood base using **Phillips pan head screws**, one in front and one in back of each Cycler. If you have questions about stability, please contact your dealer or King Technology.

In-line Installation For pools 7,000 to 40,000 gallons

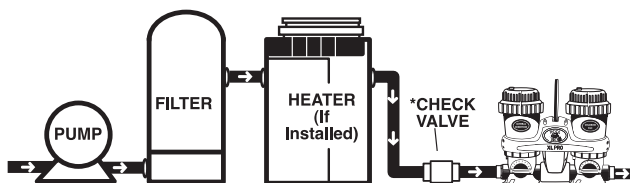

The POOL FROG XL Pro Cyclers should always be installed between the filter and pool (or between heater and pool if applicable). Never install POOL FROG XL Pro Cyclers before the heater or damage to the heater could occur.

Do NOT install in copper pipe if using POOL FROG Pac as chemical corrosion may lead to pipe failure.

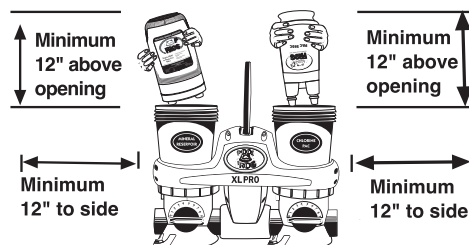
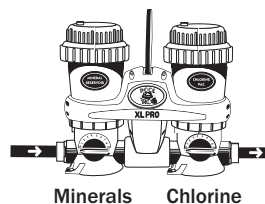
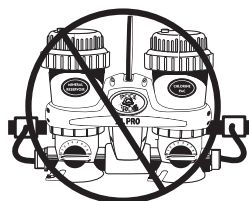

Do NOT install POOL FROG XL Pro Cyclers off-line.

Install with water flowing through the minerals first and then the chlorine.

Allow a minimum of 12" above and on each side of POOL FROG XL Pro Cyclers to ensure room for easy replacement of POOL FROG Mineral Reservoir and POOL FROG Pac.

1.

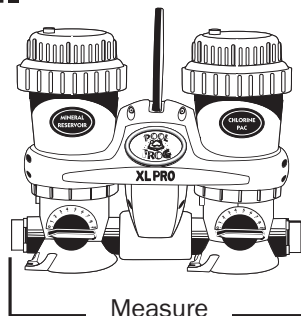

Measure the distance between outside adapters and cut out a section of pipe 3" less than that dimension.

2.

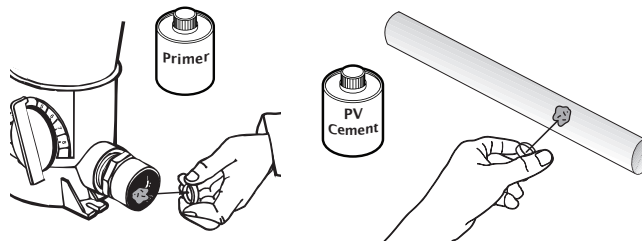

Following Primer directions, brush Primer on the inside of the adapters and to ends of pipe. Repeat this process with PVC cement following manufacturer's directions on that product.

3.

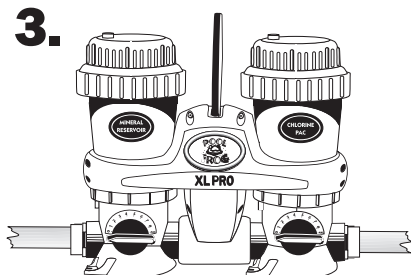

Insert PVC pipe into adapters with a twisting action. Hold in place 5 to 10 seconds to bond.

4.

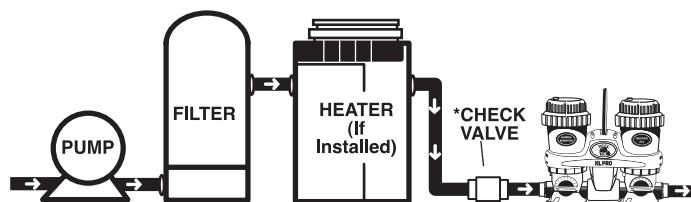

To prevent damage to heaters or filters, install a **corrosion resistant check valve** which will reduce the backflow of chlorine gas when the Cyclers are turned off.

Step 1: Preparing the Pool



1. Make sure the pool has adequate circulation. The total volume of pool water must completely circulate through the pump and filter at least 1 to 2 times per day. This usually requires 8 to 12 hours of circulation. Check with your dealer for the proper circulation time for your pool.

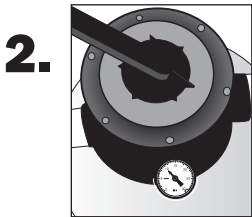

2. Check the pool's filter gauge often and periodically clean filter per the manufacturer's directions. A dirty filter will slow the flow of water which could hamper proper circulation.



WARNING

Do not exceed maximum operating pressure of 50 psi.

3. Check the Water Hardness of your fill water before adding to the pool. If calcium content is higher than 400 ppm, find a soft water source to fill your pool instead; otherwise water balance will be very difficult.

4. Check for metals in the pool such as iron or copper. Before attempting water balance, these should be removed. See your dealer for a metal out or sequesterant and follow the label directions carefully.

5. Before beginning with any pool care program, you must first balance your pool water. Take a water sample to your local pool professional (or use a complete test kit) to test for the important Water Balance Guidelines.

IMPORTANT: Always follow printed instructions on the balancing chemical packages. Add balancing chemicals in small increments one at a time with circulation running. **For best results, wait 8-12 hours** before testing again and adding any additional balancing chemicals.

Water Balance Guidelines

pH:	7.2 – 7.8
Total Alkalinity:	80 – 120 ppm
Calcium Hardness:	200 – 400
Total Dissolved Solids:	<1500
Stabilizer:	20 – 80 ppm
Free Chlorine:	0.5 – 1.0 ppm

For best results in achieving water balance, follow steps **5a through 5e** in order.

5a. Take a water sample from the pool and dip a FROG Test Strip into it.

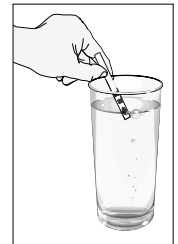

5b. Look at the **Total Alkalinity** reading first. Adjustments should be made to bring the Total Alkalinity in the range of **80 – 120 ppm** prior to making any adjustments to pH even if it throws pH off further.

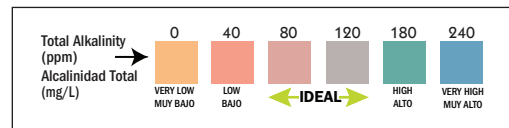

5c. After Total Alkalinity is in range, test for **pH**. It should be between **7.2 and 7.8**. If higher or lower, add a pH adjuster.

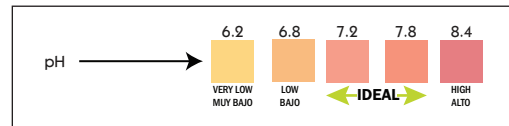

5d. Then test your Water Hardness again. If lower than 200 ppm, add Calcium Increaser. Always maintain 200-400 ppm.

5e. Lastly, test for **stabilizer** or **conditioner** levels. Add conditioner if the level is below 20 ppm. This will prevent chlorine burn off. If stabilizer level is above 80 ppm, partially drain water and re-fill.

6. Initially shock the pool with a **chlorine shock only** to rid the water of contaminants and establish a chlorine residual. Always follow the manufacturer's directions carefully. See the DANGER box below for important guidance on shocking.



DANGER

- Never add any other types of chlorine, pH adjusters, shock treatments or algaecides through the skimmer. These products should be added directly into the pool if required.
- Never use fast dissolving chlorine tablets, liquid bleach, or calcium hypochlorite in the POOL FROG XL Pro Cyclers.

Step 2: Putting the System to Work

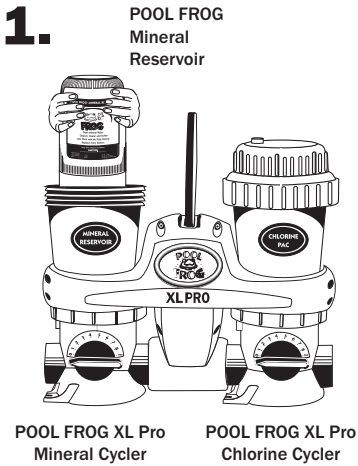

Install a POOL FROG Mineral Reservoir into the POOL FROG XL Pro Mineral Cycler. (See page 12 for directions.)

IMPORTANT: Replace the POOL FROG Mineral Reservoir every 6 months or after one pool season, whichever is shorter. After that time, you will hear the spent media inside, however it is no longer effective and must be replaced.



Replace cap and run POOL FROG XL Pro Mineral Cycler, with POOL FROG Mineral Reservoir inserted, for 10 minutes on Setting MAXIMUM.

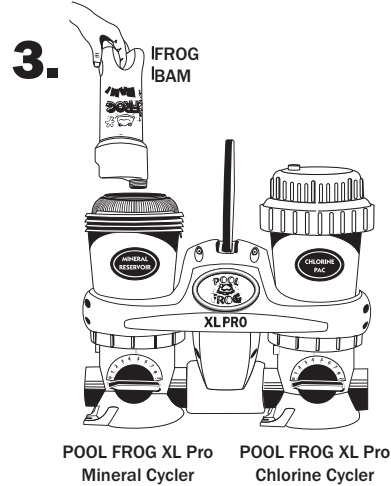

Insert FROG BAM into POOL FROG Mineral Reservoir in POOL FROG XL Pro Mineral Cycler. (See page 13 for directions.)

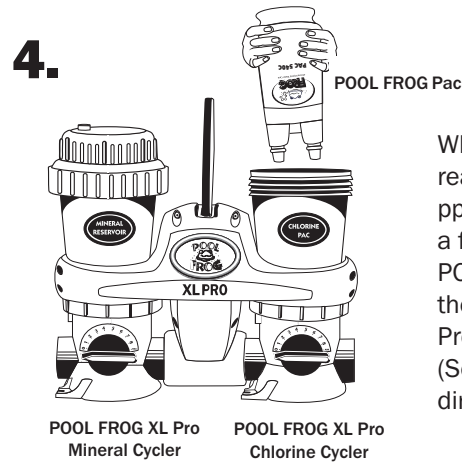

When chlorine reading is down to 1.0 ppm (which may take a few days) insert a POOL FROG Pac into the POOL FROG XL Pro Chlorine Cycler. (See pages 14-15 for directions.)

Operate

Step 3: Setting the Cyclor Control Dials

1. These Cyclers are designed to work effectively with a variety of pool equipment as long as the following basic procedures are followed.

1a. Set POOL FROG XL Pro Mineral Cyclor control dial to Setting 10. No further adjustments are needed.

1b. Set POOL FROG XL Pro Chlorine Cyclor control dial by matching up the parameters of your pool on the chart below. THIS IS A STARTING POINT ONLY and may need to be adjusted to fit your individual pool needs. See #2 below for adjusting directions.

IMPORTANT: If using a multi-speed pump, pump-run times of at least 6 hours per day at high speed are recommended for proper performance.

If running the pump at low speed only or on high speed less than 6 hours, please follow the 24 hour low-speed directions below.

POOL SIZE Gallons	SINGLE-SPEED PUMP OR HIGH-SPEED PUMP RUN TIME											
	6 HOUR PUMP RUN TIME				12 HOUR PUMP RUN TIME				24 HOUR PUMP RUN TIME			
	PUMP SIZE				PUMP SIZE				PUMP SIZE			
	3/4 hp	1 hp	1 1/2 hp	2 hp	3/4 hp	1 hp	1 1/2 hp	2 hp	3/4 hp	1 hp	1 1/2 hp	2 hp
7,000	3.5	3.0	2.5	2.5^	2.5	2.0	3.5^	3.0^	1.0	3.0^	2.5^	2.0^
9,000	4.0	3.5	3.0	2.5	3.0	2.5	2.0	3.5^	2.0	3.5^	3.0^	2.5^
12,000	4.5	4.0	3.5	3.0	3.5	3.0	2.5	2.0	2.5	2.0	1.0	3.0^
18,000	NR	4.5	4.0	3.5	4.5	3.5	3.0	2.5	3.0	2.5	2.0	1.5
25,000	NR	NR	4.5	3.5	NR	4.5	3.5	3.0	3.5	3.0	2.5	2.0
30,000	NR	NR	5.5	4.5	NR	5.0	4.5	3.5	4.0	3.5	3.0	2.5
35,000	NR	NR	6.5	5.5	NR	6.0	5.0	4.5	5.0	4.0	3.5	3.0
40,000	NR	NR	NR	6.5	NR	NR	6.0	5.0	6.0	5.0	4.0	3.5

^ - Bypass installation recommended. See "Installation Tips" on page 6. NR - This pump size is not recommended for this size pool.

24 HOUR, LOW SPEED, PUMP-RUN TIME

In order to ensure proper performance when running the pump on low speed for 24 hours per day or high speed less than 6 hours per day, bleed the air while the pump is on by unscrewing BOTH Cyclor cap knobs until water appears from both Cyclors. Then screw the knobs back on. Repeat this process each time the caps are removed for any reason. Set the control dial on the POOL FROG XL Pro Chlorine Cyclor to 6 and follow the adjustment directions below to determine the correct setting for your pool.

2.



For the first week test the pool water daily for free chlorine with FROG Test Strips to ensure correct dial setting. Continue to test weekly throughout the season.

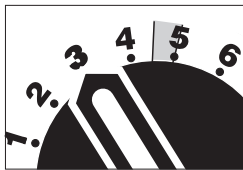

After each testing, adjust the dial up by 1/2 increment if the free chlorine reading has dropped below 0.5 ppm or adjust down by 1/2 increment if the reading has risen above 1.0 ppm. Continue this process each day until the free chlorine reading stabilizes to at least 0.5 ppm.

Remember to adjust dial by 1/2 increments only in order to prevent over chlorination which may bleach pool surfaces.

IMPORTANT: Control dial settings in excess of these recommendations could result in excess trichlor levels being discharged into the pool. This can result in bleaching or discoloration of areas around the pool inlet or in some cases bleaching or discoloration of the entire pool liner or paint. In addition, excess trichlor in the pool can create health hazards to bathers.

EXAMPLE

POOL SIZE Gallons	6 HOUR PUMP RUN TIME			
	3/4 hp	1 hp	1 1/2 hp	2 hp
7,000	3.5	3.0	2.5	2.5^
9,000	4.0	3.5	3.0	2.5
12,000	4.5	4.0	3.5	3.0
18,000	NR	4.5	4.0	3.5
25,000	NR	NR	4.5	3.5
30,000	NR	NR	5.5	4.5
35,000	NR	NR	6.5	5.5
40,000	NR	NR	NR	6.5

Find your starting dial setting by matching up the parameters of your pool on the above chart. An In ground pool with approximately 18,000 gallons with a 1 horse power pump running 6 hours a day at high speed would require a starting dial setting of 4.5.



If using another means of chlorine support, set dial on the POOL FROG XL Pro Mineral Cyclor to Maximum. Leave the POOL FROG XL Pro Chlorine Cyclor empty. Maintain a minimum chlorine reading of 0.5 ppm with a chlorine delivery device or hand feeding.

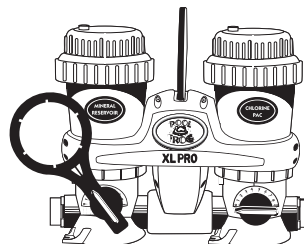

Use the handle end of cap tool if the dial is hard to turn.

Step 4: Routine Pool Care



- 1.** Run filtration Cycler enough hours to circulate all water 1 to 2 times per day. More than that could result in over chlorination.



WARNING

To prevent the build up of gas pressure in the **POOL FROG XL Pro Cyclers**, be sure the pool return line valves are open –except when opening or servicing the unit.



- 2.** Regularly test water with FROG Test Strips to maintain pH and Total Alkalinity.

NOTE: Water balance is affected by bather load, chemical usage, evaporation and the makeup of source water, so maintaining water balance regularly is important.



- 3.** Maintain 0.5 to 1.0 ppm free chlorine level at all times.

Note: These lower chlorine levels are only acceptable when using FROG minerals.



DANGER

Do not contaminate the **POOL FROG XL Pro Cyclers**, **POOL FROG Mineral Reservoir**, **POOL FROG Pac** or **FROG BAM** with dirt, organic matter, pool chemicals (such as calcium hypochlorite or pool shocks), fertilizers or other household chemicals. Contact between any of these substances and the **POOL FROG XL Pro Cyclers**, **POOL FROG Mineral Reservoir**, **POOL FROG Pac** or **FROG BAM**, will result in a chemical reaction with the generation of heat, liberation of hazardous gasses and fire or explosion.

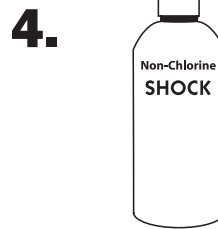

- 4.** Shock the pool every other week or as needed. We recommend a non-chlorine shock as reducing chlorine use is the goal of FROG products. However, using a chlorine shock is OK too.



DANGER

- Never add any other types of chlorine, pH adjusters, shock treatments or algaecides through the skimmer. These products should be added directly into the pool if required.
- Never use fast dissolving chlorine tablets, liquid bleach, or calcium hypochlorite in the **POOL FROG XL Pro Cyclers**.



- 5.** Before closing the pool for winter, use FROG BAM following the directions on page 13.

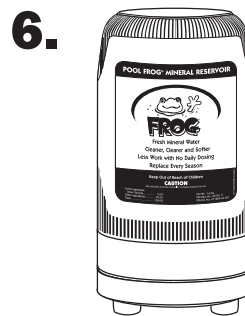

- 6.** Remember to replace **POOL FROG Mineral Reservoir** and all other **POOL FROG** replacements as directed.

Replacing a POOL FROG Mineral Reservoir

Must be replaced every 6 months or after one pool season.



1.

POOL FROG® MINERAL RESERVOIR

The Complete Low-Chlorine Alternative®
 www.FrogProducts.com • 800-222-0169
 Series 5400 (01-12-5462)
 Serial No. _____ FOR POOLS UP TO 40,000 GALLONS

Product Description: The POOL FROG Mineral Reservoir is the heart of an advanced pool care system that destroys bacteria. The patented mineral formula in the POOL FROG Mineral Reservoir also neutralizes acids, which helps keep the pH in an acceptable range with less monitoring. The controlled release of minerals provides an optimum level of protection in your pool. The FROG Mineral System™ reduces chlorine use up to 50%*. Simply use with at least 0.5 ppm of an EPA registered source of chlorine such as the POOL FROG Bac Pac (EPA Reg. No. 53735-2) or a chlorine delivery device. Using the POOL

Check the top of the box and back label of product to make sure you have the correct POOL FROG Mineral Reservoir to fit your POOL FROG XL Pro Mineral Cycler.

IMPORTANT: The POOL FROG Mineral Reservoir must be replaced every 6 months or after one pool season whichever is shorter.

2.

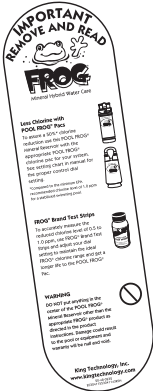

IMPORTANT: Remove and read the information card.

Please note: Complete instructions for inserting a POOL FROG Mineral Reservoir, FROG BAM and POOL FROG Pac are included inside the POOL FROG Mineral Reservoir



DANGER

- Never use fast dissolving chlorine tablets, liquid bleach, or calcium hypochlorite in the POOL FROG XL Pro Cyclers.

3.



Turn off pump. Turn dial to Setting 0 on the POOL FROG XL Pro Mineral Cycler. This reduces the flow of water into the unit when the cap is open.

4.

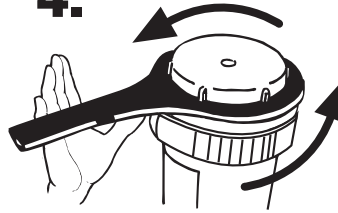

Open POOL FROG XL Pro Mineral Cycler cap. Use the Cycler cap tool included with POOL FROG XL Pro to loosen cap on POOL FROG XL Pro Mineral Cycler by hitting the handle with the flat of your hand counter clockwise.

5.

Remove the POOL FROG Mineral Reservoir and discard if it has been used for one pool season or 6 months, whichever is shorter.

6.

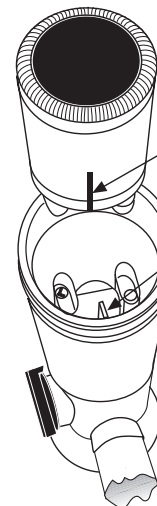

SLOT IN THE POOL FROG MINERAL RESERVOIR

FIN INSIDE POOL FROG XL PRO MINERAL CYCLER

Find slot on side of POOL FROG Mineral Reservoir and line up with fin inside the POOL FROG XL Pro Mineral Cycler. Lower POOL FROG Mineral Reservoir into POOL FROG XL Pro Mineral Cycler until secure.

7.



Mark your calendar ahead for the six month replacement of the POOL FROG Mineral Reservoir. **Once wetted, the time-released mineral coating of this product is effective up to 6 consecutive months or one pool season, whichever is shorter. After that time you will hear the spent media inside, however, it is no longer effective and must be replaced.**

Using FROG BAM for an Algae-Protection Guarantee

If you are not using FROG BAM, refer to pages 14-15 for Using the POOL FROG Pac. See FROG BAM product labeling for complete directions for use (EPA Reg. No. 53735-9).

For a preventive dose add:

- One FROG BAM for pools up to 15,000 gallons.
- Two FROG BAM for pools between 15,000 and 30,000 gallons.
- Three FROG BAM for pools between 30,000 and 40,000 gallons.

NOTE: If using directly after a shock treatment, test the water first to ensure the pH is in the proper range of 7.2-7.8 and the chlorine level is no more than 4.0 ppm. Avoid using other chemicals until this product has been circulated (filtered) for at least 24 hours.



DANGER

Never use fast dissolving chlorine tablets, liquid bleach, or calcium hypochlorite in the POOL FROG XL Pro Cyclers.

Important: If storing FROG BAM prior to use, always keep in a cool, dry place away from children and pets.



1. Remove cap from FROG BAM without removing seal.

Turn off pump. Turn control dial to Minimum or 0. Open POOL FROG XL Pro Mineral Cycler cap.

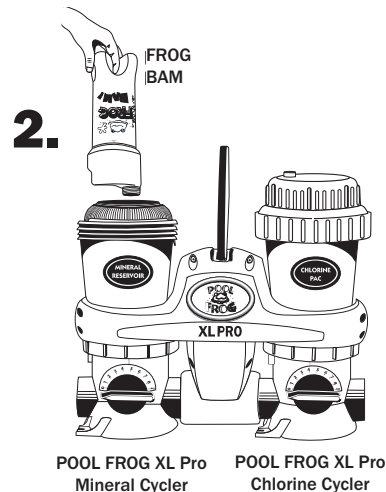

2. Insert upside down into the open center of the POOL FROG Mineral Reservoir pushing down firmly on FROG BAM bottle allowing key in POOL FROG XL Pro Mineral Cycler to puncture seal.

Looking down at top of bottle

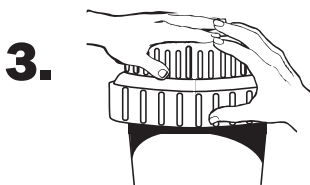

3. Replace cap by hand only. **DO NOT OVER TIGHTEN.**



4. Turn control dial on POOL FROG XL Pro Mineral Cycler to Setting MAXIMUM.

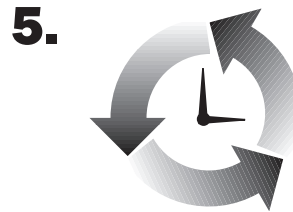

5. Turn pump on for 90 minutes allowing FROG BAM to circulate through pool.



6. To remove expended FROG BAM bottle, turn pump off and turn dial to Setting 0.

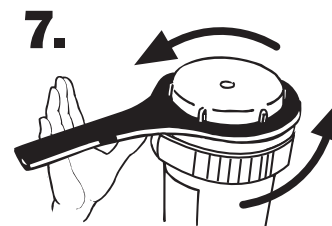

7. Remove POOL FROG XL Pro Mineral Cycler cap.

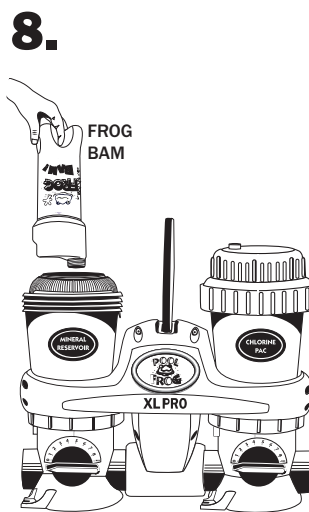

8. Lift FROG BAM up and allow any water in the container to drain through the POOL FROG XL Pro Mineral Cycler before discarding in trash or offering for recycling. Do not reuse or refill this container.

NOTE: If water shows more than a hint of blue inside POOL FROG XL Pro Mineral Cycler, replace the cap, turn dial to Maximum and run the pump for one minute.

8a. If pool size requires additional FROG BAM, repeat steps 1-8.

8b. When water is clear in POOL FROG XL Pro Mineral Cycler, insert a POOL FROG Pac according to the instructions on pages 14-15.

Using POOL FROG Pac



POOL FROG Pac is recommended to assure up to 50% reduction in chlorine use*. POOL FROG Pac sold separately. (EPA Reg. No. 53735-2)



DANGER

Never use fast dissolving chlorine tablets, liquid bleach, or calcium hypochlorite in the POOL FROG XL Pro Cyclers.



WARNING

Avoid sparks, smoking, or any open flame near POOL FROG XL Pro Cyclers or chemicals.

IMPORTANT: Read the label on the POOL FROG Pac carefully before using.

- 1.** Cut handle from POOL FROG Pac using a PVC cutting tool. **(KEEP OUT OF REACH OF CHILDREN).**

Indent in plastic

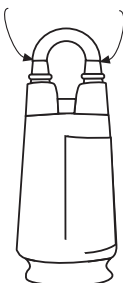

- A.** Find the indent in the plastic.

PVC cutting tool available at local hardware stores.

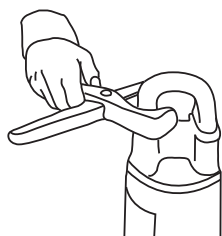

- B.** Place curved section of tool around the narrow end of one pac tower and line up blade on indent.

Finished cut ends



- C.** Squeeze the handles together. Repeat for other side.

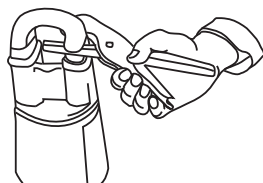

- D.** Make sure the blade comes straight across on the indent line for a clean cut.

- E.** If openings are pinched together, open with fingers or re-cut closer to the colored screens inside POOL FROG Pac. Leave at least 1/4" of plastic to fit into POOL FROG XL Pro Chlorine Cycler base.

Avoid a pinched opening.

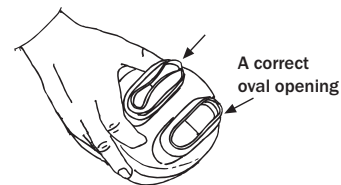

- 2.**

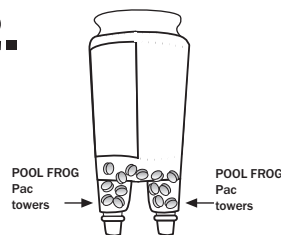

Invert POOL FROG Pac and shake slightly until chlorine tablets fall into tower areas.

- 3.**

Turn off pump. Turn control dial on POOL FROG XL Pro Chlorine Cycler to 0. Remove cap from POOL FROG XL Pro Chlorine Cycler and stand back to let any chlorine fumes dissipate.

Continued to page 15

Continued....Using POOL FROG Pac

4.

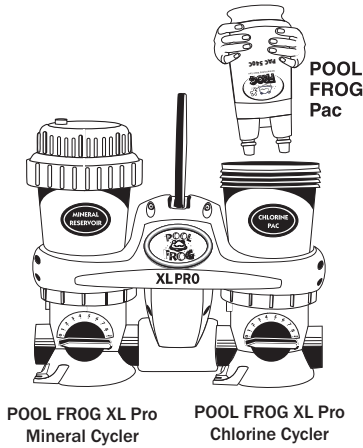

Insert POOL FROG Pac into POOL FROG XL Pro Chlorine Cycler, lining up the openings in the POOL FROG Pac with keys in the POOL FROG XL Pro Chlorine Cycler.
NOTE: Openings are a different shape than keys.

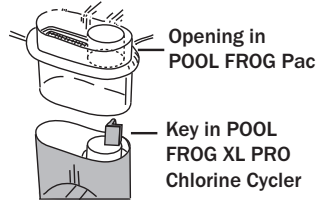

5.

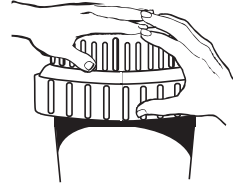

Replace cap by hand only.
DO NOT OVERTIGHTEN. DO NOT USE CAP TOOL TO TIGHTEN CAP. FOR REMOVAL ONLY.



6.



The chlorine pac container is made of HDPE plastic. Non-refillable container. Do not reuse or refill this container. Offer for recycling if available. Rinse thoroughly before recycling or discarding in trash.

7.



Mark your calendar ahead for the approximate replacement times for the POOL FROG Pac.

Winterizing

1.



Turn pump off and turn dial to Setting 0.

2.

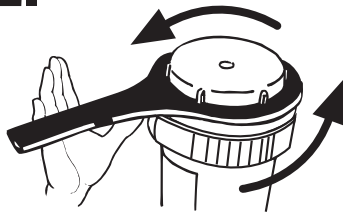

Remove both caps.

3.

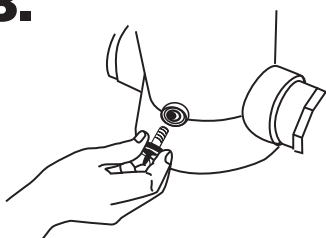

Unscrew knob in the back of both POOL FROG XL Pro Cyclers. Allow all water to drain.

4.



Remove the POOL FROG Mineral Reservoir and discard in trash. You will hear spent media inside, however it is no longer effective.

If POOL FROG Pac still contains chlorine, wrap in plastic bag and store in shed or cool, dry, well-ventilated location away from children, pets, cars, motorcycles or anything metal that can rust, pit, etc.

If empty, rinse and recycle.



WARNING

Avoid sparks, smoking, or any open flame near POOL FROG XL PRO Cyclers or chemicals.

5.

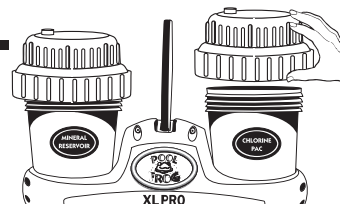

Replace both caps and knobs loosely.

Troubleshooting

For more in-depth troubleshooting, go to frogproducts.com or call King Technology at 800-222-0169.

Problem	Remedy		
<p>1. What do I do if the water looks cloudy?</p>	<p>1. Make sure your filtration system is working properly (i.e. clean filter, skimmer and pump basket).</p> <p>2. Make sure circulation time is adequate – increase pump time if not.</p>	<p>3. Make sure the pool is properly balanced (see page 8).</p> <p>4. Shock the water to eliminate build up of any organic matter.</p>	<p>5. Make sure pool has a free chlorine reading of 0.5 to 1.0 ppm.</p> <p>6. Check with your dealer for more information.</p>
<p>2. What do I do if the water turns color?</p>	<p>1. Algae may be trying to form – shock the pool, increase circulation time if needed and clean the filter.</p>	<p>2. Metals in the fill water may have been oxidized. Have the pool tested. See pool dealer if a metal control product is required.</p>	<p>3. Check with your dealer for more information.</p>
<p>3. What do I do if algae forms in or on my pool?</p>	<p>1. Use FROG BAM or an effective algaecide per the directions on the bottle and brush the sides of the pool often.</p> <p>2. Clean the filter and shock the pool with chlorine daily</p>	<p>until water clarity returns.</p> <p>3. If you are in an area of the country that struggles with algae growth, see your dealer regarding a 90-day Algae Protection Guarantee using</p>	<p>FROG BAM. See product hang tag for guarantee details.</p> <p>4. Check with your dealer for more information.</p>
<p>4. What do I do if I am under chlorinating with the POOL FROG Pac?</p>	<p>1. If you are unable to maintain 0.5 to 1.0 ppm, first make sure there are chlorine tablets in the tower areas of the POOL FROG Pac and it is installed properly. If a correction was made, test the water in 24 hours.</p> <p>2. If still low, turn the dial up one setting and test the water again in 24 hours. Continue raising the setting by one increment each day until the proper reading is achieved.</p>	<p>3. Shock the pool if the reading has been lower than 0.5 ppm for more than one day.</p> <p>4. Make sure pump run time is at least 6 hours on high speed (40 gpm or higher) or if not, bleed the air from both cap knobs each time cap is open.</p> <p>5. Contact your dealer to have your back pressure tested. If under 4 psi consider a smaller eye-ball fitting in the return jet.</p>	<p>6. Check for a suction side leak by looking for air bubbles in your pump basket or at the return jet. Your water level will be low and the skimmer will be taking in air. Contact dealer for help in correcting this situation.</p> <p>7. Contact King Technology's Customer Service Department at 800-222-0169.</p>
<p>5. What do I do if I am over chlorinating with the POOL FROG Pac?</p>	<p>1. If the chlorine reading is over 3.0 ppm, remove the Chlorine Pac from the POOL FROG XL Pro Chlorine Cyclor and test the water daily until the reading is down to 1.0 ppm.</p> <p>2. Reinsert the POOL FROG Pac, lower the dial one setting and test the water again in 24 hours. If the reading has risen, lower the dial one setting again. Continue this process until</p>	<p>proper reading is achieved.</p> <p>3. If over-chlorinating at the lowest possible setting, consider decreasing the circulation time. Depending on your pump size, you may be circulating the water more than is necessary.</p> <p>4. Contact your dealer to have your back pressure tested. If over 8 psi consider a larger eye-ball fitting in the return jet.</p>	<p>5. Check to see if the pressure relief valve is loose or missing and replace. It is a clear plastic piece approximately 1" long installed inside near the base. If loose or missing, it can provide another avenue for water to reach the chlorine.</p> <p>6. Contact King Technology's Customer Service Department at 800-222-0169.</p>

Parts List

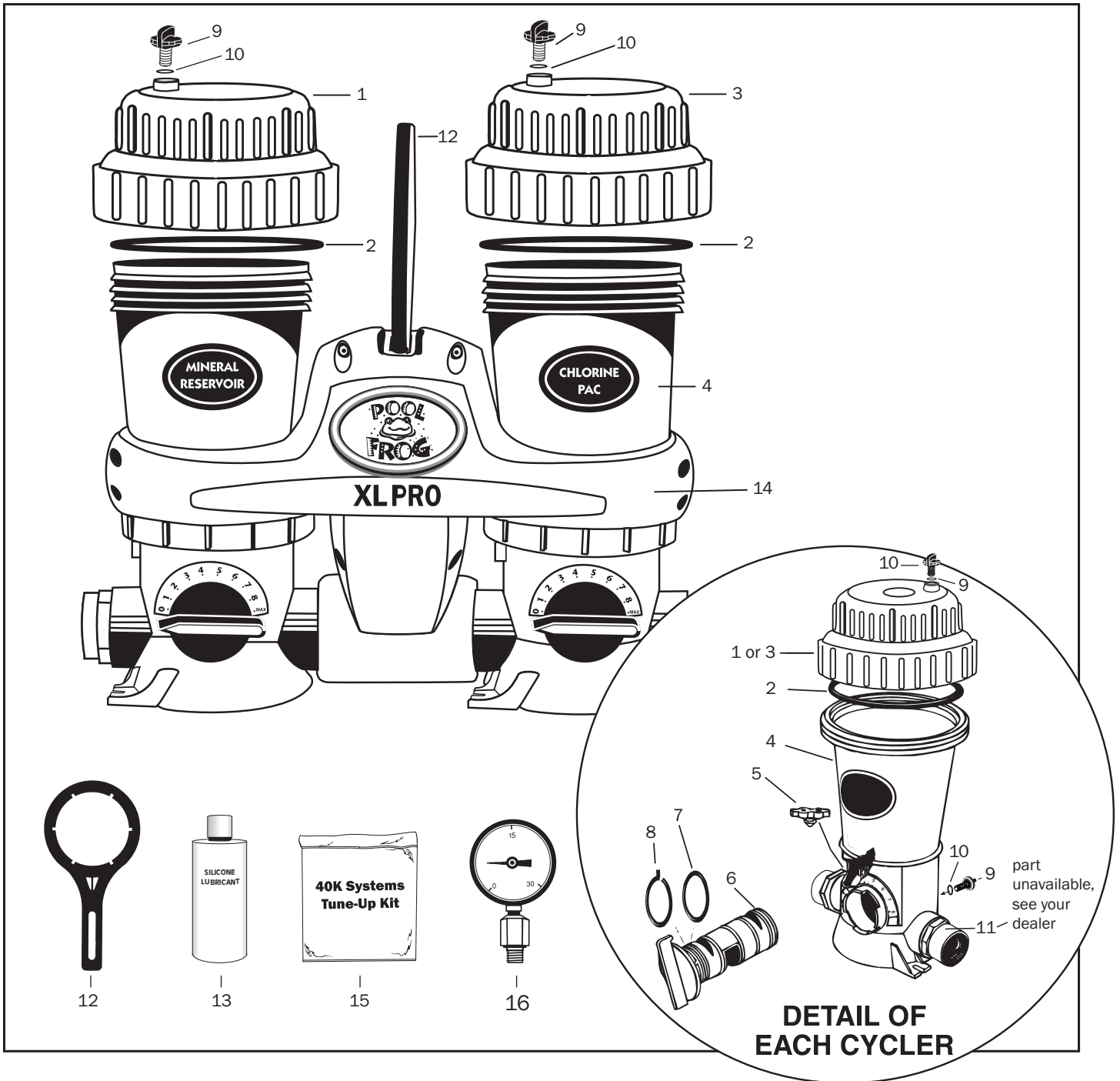

INCLUDED WITH POOL FROG XL Pro CYCLERS

REF. #	DESCRIPTION	QTY. INCLUDED
1, 2, 3	Caps w/O-Rings	2
4	Body	2
5	Pressure Relief Valve	2
6, 7, 8	Control Dial with O-Ring & Snap Ring	2
9 & 10	Knob with O-Ring	4
11	2" Male Adapter	2
12	Cap/Control Dial Tool	1
13	Silicone Lubricant	1
14	Shroud	1

REPLACEMENT PARTS FOR POOL FROG XL Pro CYCLERS

REF. #	PART NO.	DESCRIPTION
1 & 2	01-22-9417	Cap w/O-Ring - Mineral Cycler
3 & 2	01-22-9418	Cap w/O-Ring - Chlorine Cycler
2	01-22-9926	Cap O-Ring
5	01-22-9486	Pressure Relief Valve
6, 7, 8	01-22-9446	Control Dial with O-Ring & Snap Ring
7 & 8	01-22-9456	Control Dial O-Ring Kit
9 & 10	01-22-9946	Knob with O-Ring
12	01-22-8870	Cap/Control Dial Tool
13	01-22-9970	Silicone Lubricant
15	01-22-9950	40k Tune-Up Kit
16	01-22-4000	Pressure Gauge

POOL FROG XL Pro Cyclers Maintenance

Replacing the Control Dial O-Rings

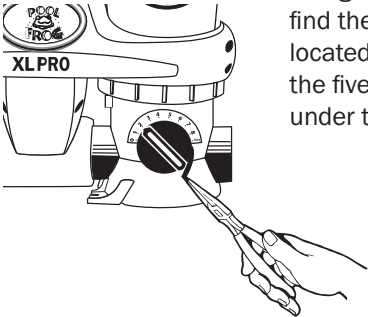
1.  Using a needle nose pliers, find the snap ring tail located at approximately the five o'clock position under the control dial.

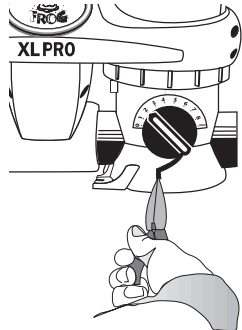
2.  Pull down and out of the groove.

3.  Using a large screwdriver, loosen the control dial. Carefully pry the dial until it pulls out.

4.  Carefully replace the rubber O-ring without stretching it. Apply silicone lubricant, that came with your POOL FROG XL Pro Cyclers, on the O-ring.

Product # 01-22-9970

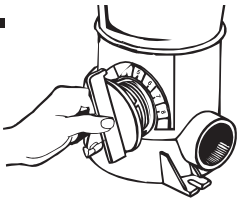
5.  Push control dial completely into the housing and turn the dial to setting 2.

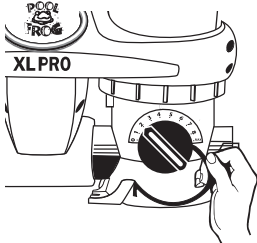
6.  Insert the non-lipped end of snap ring into the groove opening beginning at the 5 o'clock position and push it up so that it threads itself around the control dial.

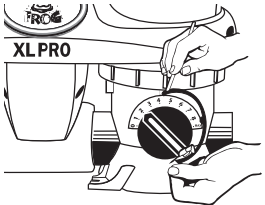
7.  Using a small screwdriver or pointed tool to help guide it, make sure the snap ring stays in the groove as it is inserted.

Replacing Cap O-Ring

1. Remove old O-ring.

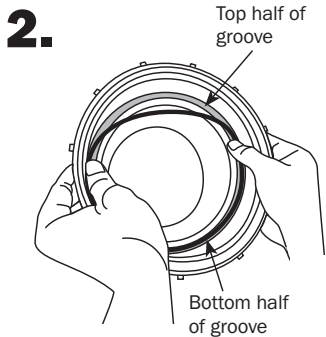

Place new O-ring in bottom half of groove.

Place your thumbs on each side of the cap over the O-ring in the groove.

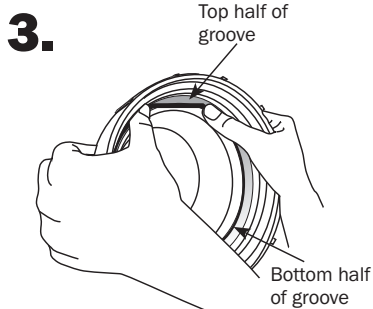

Roll your thumbs back and forth over the O-ring while pushing upward until the O-ring falls into the top of the groove.



Product # 01-22-9970

Lubricate O-ring every couple of months with silicone lubricant that came with your POOL FROG XL Pro Cyclers.

DO NOT USE petroleum based lubricants.

Replacing Knobs

To replace, simply unscrew old knob and replace with the new one.

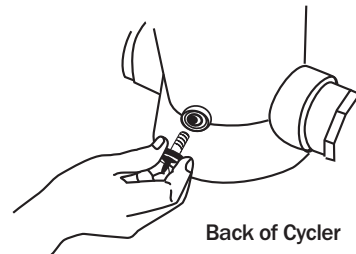

Back of Cycler

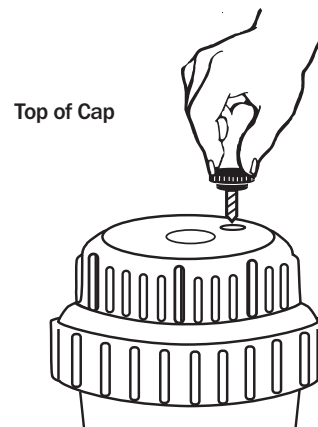

Top of Cap

POOL FROG XL Pro Two-Year Limited Warranty

Register your warranty today at frogproducts.com/reg and extend the standard 2-year warranty to 10 years of coverage.

King Technology, Inc. will warrant this unit with a complete replacement for the original purchaser, should it prove defective by reason of improper workmanship and/or material for a period of two (2) years from the date of original purchase/installation. This warranty covers body, cap and control dial excluding O-rings. King Technology holds the option of replacing any defective part without charge if it is determined to be all that is needed to correct any situation. Parts used for replacement, with the exception of O-rings, are warranted for the remainder of the original warranty.

1. To obtain warranty service, you must deliver product to King Technology or its nearest authorized dealer. Shipping expenses are the purchaser's responsibility. The name of the nearest authorized dealer can be obtained at frogproducts.com/find-a-dealer or by calling King Technology at 1-800-222-0169. Proof of purchase is required when requesting warranty service. Purchaser must present the sales receipt or other document which establishes proof of purchase. To extend your warranty to 10 years, go to frogproducts.com/reg.

2. This warranty does not cover defects caused by: modification, alteration, repair or service of the product contrary to the accompanying instructions; physical abuse to or misuse of the product or operation or installation in a manner contrary to the accompanying instructions. This warranty also excludes all costs arising from the installation, adjustment, removal or replacement of defective units or parts. This warranty also excludes any and all claims arising out of the chemicals used in the product or their characteristics.

3. Any express warranty not provided for herein, and any remedy for breach of warranty or breach of contract which, but for this provision, might arise by implication or operation of law, is hereby expressly excluded and disclaimed. The implied warranties of merchantability and of fitness for any particular purpose are expressly limited to a term of two years. Some states do not allow limitation on how long an implied warranty lasts, so the above limitation may not apply to you.

4. Under no circumstance shall King Technology be liable to purchaser or any other person for any damage or loss incurred because of any chemicals used in the product or their physical characteristics, or interruption of service of the product, or any special, incidental or consequential damages or losses, whether arising out of breach of warranty, breach of contract or otherwise. Some states do not allow the exclusion or limitation of incidental consequential damages, so the above limitation or exclusion may not apply to you.

5. Misuse or failure to use the proper POOL FROG Mineral Reservoir and POOL FROG Pac may cause damage to equipment or personal injury. All warranty null and void if this product is not used with the recommended POOL FROG Mineral Reservoir and POOL FROG Pac.

Don't forget to register your warranty and sign up to receive emails on special offers and helpful water care tips. Visit frogproducts.com/reg

Made in U.S.A.
Patents: kingtechnology.com/IP

MANUFACTURED BY



© King Technology, Inc. The following are trademarks of King Technology, Inc.

FROG®	FROG BAM®	SmartChlor®
POOL FROG®	FROG Serene™	FROG Jump Start®
POOL FROG XL PRO®	FROG Filter Mate™	Fresh Mineral Water®
Flippin' FROG®	INSTANT FROG®	New Water®
Flippin' FROG XL®	FROG @ease®	Perform-Max

530 11TH AVE S, HOPKINS, MN 55343 | 800.222.0169 | frogproducts.com