



# TriStar® VS 950

Variable-Speed Pump

**SIMPLE INSTALLATION WITH QUIETER-THAN-EVER PERFORMANCE**

**No-rib strainer basket with see-through cover** ensures easy debris removal

**Upgraded motor drive** delivers significantly quieter high-speed operation than other leading models

**Advanced hydraulic design** provides ample power to replace most high-performance pumps up to 3 HP



**EXPERT LINE**  
ONLY FROM POOL PROS



**Wall-mountable touchpad control** can be rotated in four directions

**Side and rear ports** accommodate both high and low voltage connections for simple installation

**Permanent magnet, totally enclosed fan-cooled motor** offers more efficient operation and long-lasting reliability

**INDUSTRY-LEADING ENERGY EFFICIENCY**

As a member of the TriStar® VS family—the most energy-efficient pumps among leading brands, according to EPA ENERGY STAR® third-party testing—TriStar VS 950 saves pool owners up to \$1,500 per year. Its ENERGY STAR rating means local energy rebates may apply, too.

**DESIGNED FOR DURABILITY**

Built with a chemical-resistant Viton® seal and accompanied by a 4-year extended warranty, TriStar VS 950 offers powerful corrosion protection for years of reliable performance.

**SEAMLESS RETROFITTING**

With dual-voltage capabilities, two pump base options and 2" x 2½" CPVC union connections, TriStar VS 950 is easy to install in both new and existing pool pads and doesn't require costly rewiring.



**SPECIFICATIONS**

MODEL NUMBER	STAND ALONE	RELAY CONTROL	HAYWARD AUTOMATION	VOLTAGE	TOTAL HP	SPEED RANGE	UNION CONNECTIONS	EXTENDED WARRANTY
SP32950VSP	•	•	•	230/115V	2.7/1.5	600-3450 RPM	2" x 2.5"	4 years

**TRISTAR VS 950 DIMENSIONS (INCHES)**

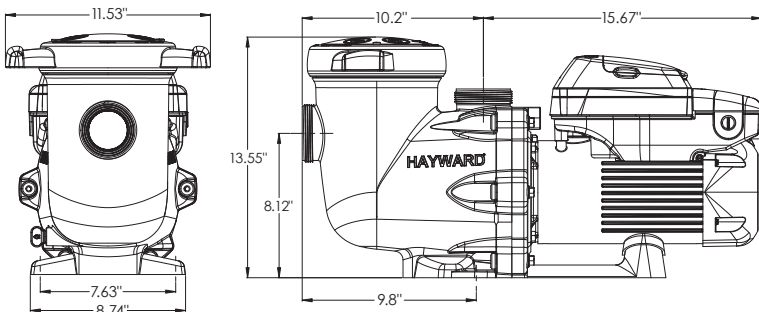

**TRISTAR VS 950 PERFORMANCE COMPARISON**

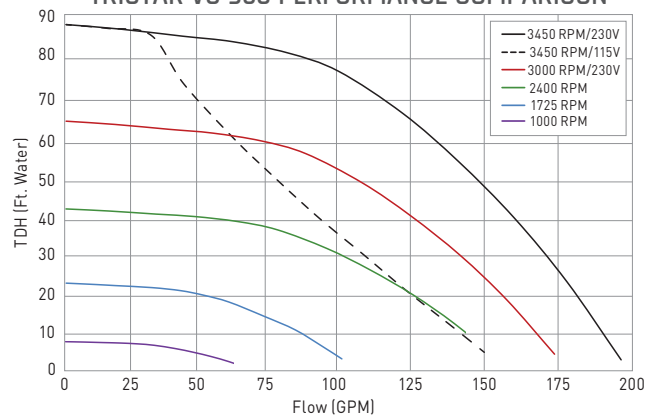

\* Compared to single-speed pumps.

TriStar VS 950 pumps are listed by:



» [hayward.com](http://hayward.com) » 1-888-HAYWARD | Pumps » Filters » Heating » Cleaners » Sanitization » Automation » Lighting » Water Features » White Goods

Hayward, Hayward & Design, the H logo and TriStar are registered trademarks of Hayward Industries, Inc. ENERGY STAR is a registered mark owned by the U.S. government. All other trademarks not owned by Hayward are the property of their respective owners. Hayward is not in any way affiliated with or endorsed by those third parties. © 2019 Hayward Industries, Inc.

DLITTSVS95019