

# CLEARWATER II CARTRIDGE FILTER INSTRUCTIONS

# CLEARWATER II™

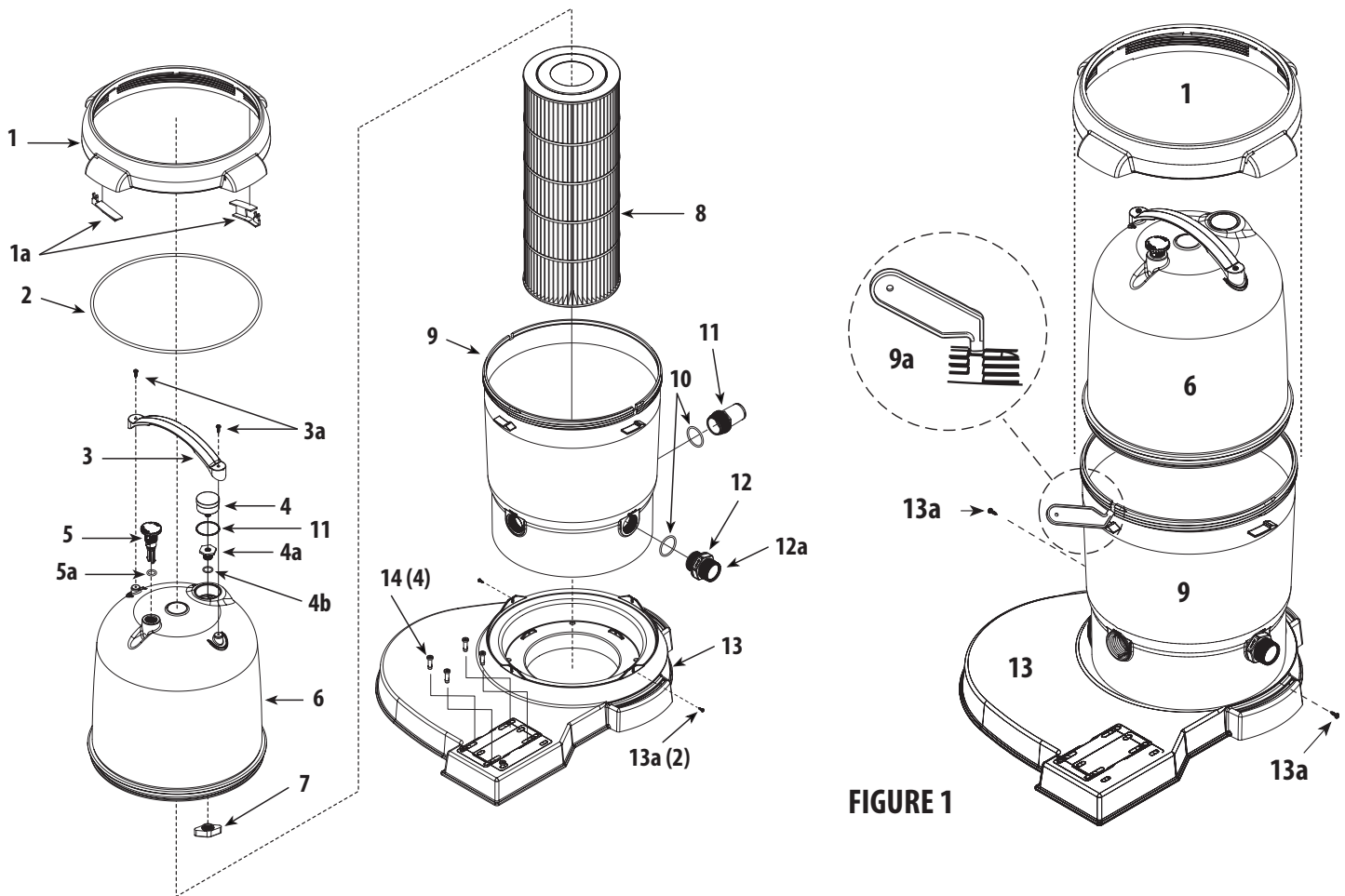

FIGURE 1

## CLEARWATER II CARTRIDGE FILTER REPLACEMENT PARTS

Item	Part No.	Description	Item	Part No.	Description
1	<b>718-7251</b>	Filter Nut ( <i>sold with Lid Assembly only</i> )	8	<b>817-0075P</b>	Cartridge - 75 sq. ft.
1a	<b>519-7451</b>	Handle Assembly (2)		<b>817-0100P</b>	Cartridge - 100 sq. ft.
2	<b>805-0460</b>	Lid O-Ring		<b>817-0125N</b>	Cartridge - 125 sq. ft.
3	<b>519-7601</b>	Lid Handle		<b>817-0150N</b>	Cartridge - 150 sq. ft.
3a	<b>819-9002</b>	#12 x 3/4 S/S Phillips Head Screw		<b>817-0200N</b>	Cartridge - 200 sq. ft.
4	<b>830-4000SS</b>	Pressure Gauge	9	<b>515-7251</b>	Body - Filter Bottom
4a	<b>519-7431</b>	Pressure Gauge - Fitting Adapter	9a	<b>519-7470</b>	Filter Wrench (see Figure 1)
4b	<b>805-0117SD</b>	O-Ring	10	<b>805-0224</b>	O-Ring
5	<b>602-0201</b>	Air Relief Plug	11	<b>417-6241</b>	1 1/2 MPT x 1 1/2 Male Smooth Hose Adapter
5a	<b>805-0207</b>	O-Ring - Air Relief	12	<b>500-5300</b>	Drain Assembly
6	<b>511-7321</b>	Lid Assembly - Small (75 & 100 sq. ft.)	12a	<b>505-2030</b>	Drain Cap
	<b>511-7331</b>	Lid Assembly - Large (125, 150 & 200 sq. ft.)	13	<b>672-7401</b>	Clearwater II Base
7	<b>519-7441</b>	Wing Nut	13a	<b>819-0004</b>	#10 x 1 S/S Phillips Head Screw

## INSTRUCTIONS

The Clearwater II Cartridge Filter is ideal for new pools or as a replacement for existing pools. The Filter Tank is constructed of high-strength thermoplastic and a reusable cartridge element. The Clearwater II Cartridge Filter will provide years of superior operation and crystal clear, sparkling water.

### INSTALLATION INSTRUCTIONS

1. Place filter on a level, secure surface (concrete slab, patio block, optional, etc.) Be sure to position the filter so that the instructions, warnings and pressure gauge are visible to the operator. Place filter with the side marked "inlet" facing pump assembly. Also, position the filter so that the piping connections and drain port are convenient and accessible for servicing and winterizing. Provide sufficient clearance around filter to permit visual verification that all connections are properly installed. Provide sufficient space above filter to remove lid for cleaning and servicing. This distance will vary with the model of filter you are installing.
2. Make all plumbing connections in accordance with local plumbing and building codes.
3. Open air release knob. Plug in and turn on pump. Air will pass out of the filter through the air release knob. Once water discharges from knob, close it.

### CLEANING INSTRUCTIONS

If the pressure gauge on your filter reads 5 PSI or higher than the original starting pressure, the filter needs to be cleaned. The Clearwater II Cartridge Filter System features the exclusive 1-2-3 Safety Locking System to ensure safe and simple filter maintenance.

1. Turn off pump. **WARNING: Never attempt to clean filter while pump is running. This is a pressurized vessel. It could cause severe injury or harm to your person.** Plug skimmer and pool return lines or drain pool water level to below pool return line.
2. Slowly open the air release knob on top of filter until the pressure gauge reads "0". Open drain cap at bottom of filter and allow water to flow.
3. Press the yellow safety latch on the underside of the locking nut and turn the nut counterclockwise to remove the lid. Rinse the cartridge element with a garden hose. There is no need to remove the element from the filter.
4. Reassemble lid and follow start-up procedures from original instructions.

**My Original Starting Pressure is \_\_\_\_\_ PSI (Pounds per Square Inch). I should clean the filter at \_\_\_\_\_ PSI.**

## LIMITED WARRANTY

Waterway Plastics manufactures its products and equipment in accordance with very high standards of workmanship. We use the best materials available and maintain the highest quality procedures practical in the industry. In accordance, Waterway warrants its products as follows:

All plastic parts such as jets, valves, skimmers, manifolds, suction, lights, and other plastic components manufactured by Waterway will be replaced or repaired, if the defects are determined by Waterway to be the responsibility of Waterway Plastics, for a period of three years from the date of installation. The warranty does not cover filter cartridges, D.E. grids, O-rings, pressure gauges, pump seals, light bulbs or any parts not manufactured by Waterway. Warranty applies to OEM's and Distributors of Waterway Products.

The Supreme and Hi-Flo Pumps will receive limited warranty from any defect in material or workmanship for one year from the date of manufacture. This includes the motor but not the motor seal.

All thermoplastic molded filter bodies and rotational molded sand filter bodies have a warranty of ten years, warranted on a pro-rata life basis. If a defect becomes apparent during the first year, the body will be exchanged for a new body if the defects are determined by Waterway to be the responsibility of Waterway Plastics. If a defect becomes apparent after the first year from the date of manufacture which, in the opinion of Waterway, will require replacement, the

body will be exchanged for a new tank on an adjusted service pro-rata life basis. Charges to the owner, on the pro-rata life basis, will be determined by the actual number of months installed beginning with the date of installation.

Products that fail or become defective during the warranty period, except as a result of improper installation, bad water chemistry, accidents or negligence on behalf of the owner, freezing, earthquakes, fire floods, or other acts of nature, shall be repaired or replaced at Waterway's option without charge to the owner. This process will be completed within 90 days of receipt of the defective product barring delays caused by the acquisition of component parts not manufactured at our facility.

To obtain warranty replacements or repair, defective products should be returned (transportation paid) to the place of purchase, or to Waterway. It should include a description of the defect and the circumstances surrounding the incident or problem.

Waterway shall not be responsible for cartage, removal and/or reinstallation labor, or any other such costs incurred in obtaining warranty replacements. Warranty applies to OEM's and Distributors of Waterway Products.

This warranty gives you specific legal rights. You may also have other rights which vary from state to state.



# Waterway™

2200 East Sturgis Road, Oxnard, CA 93030 • Ph. (805) 981-0262 • Fax (805) 981-9403

www.waterwayplastics.com • waterway@waterwayplastics.com