



BRILLIANT WONDERS QUICK START GUIDE

For Colorwheel Control Installation



1

Leave protective covers on the waterfall face and inlet throughout the installation (to prevent debris from getting into the product).

2

ELECTRICAL NOTCH
(3.5" W x 3.0" D recommended)

PLUMBING NOTCH
(3.5" W x 3.5" D recommended)
NOTE: Larger waterfalls have 2 or 3 inlets.

BODY SUPPORT CUTOUT
(2" wider than waterfall recommended)

STEEL REBAR SUPPORT
(Recommended)

3

Use electrical conduit from box to waterfall

Connect power cable to LED strip. Clue electrical cable PVC fitting to back side. Press in rectangle plug on opposite side. Leave enough slack to allow servicing on LED strip from front access door.

4

WATERFALL
Leave about 1/8" overhang after tiles are installed

TILE

CONCRETE



5

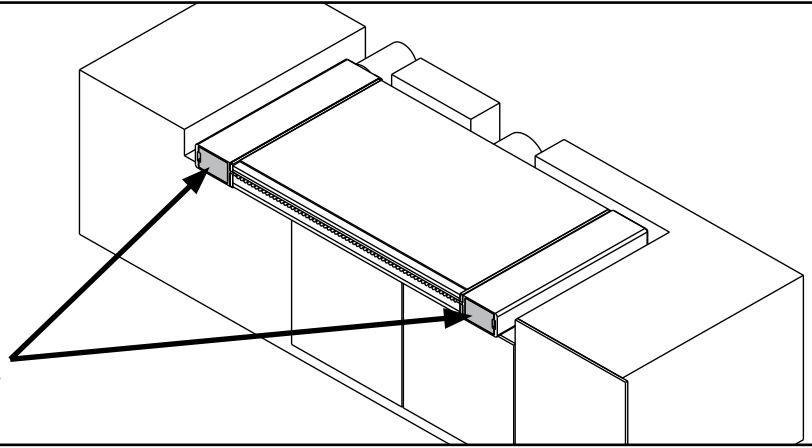

Do not cover access doors with tile, stone, or any substrate.

6

PLUMBING DIAGRAM

Use 2" schedule 40 pipe on a dedicated pump and suction. Mount anti-vortex suction covers 18" above bottom of pool. Always install at least two suction per pump as required by law. Filter strainer required. Install rock trap on each waterfall. **Rock trap does not replace filter, filtered water must be used.**

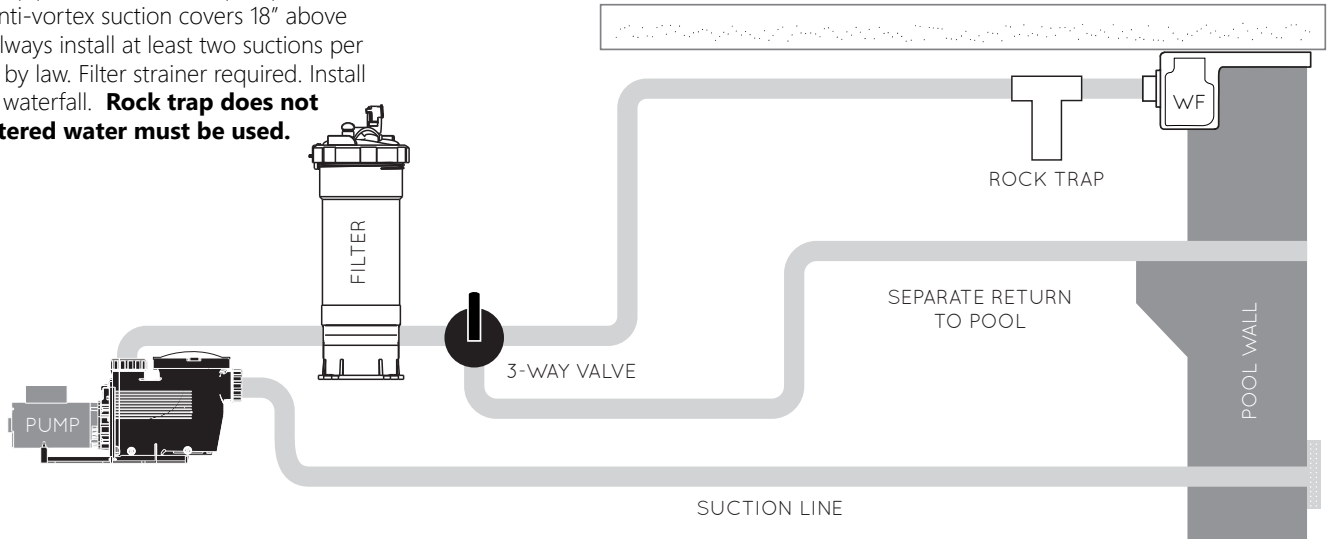

7

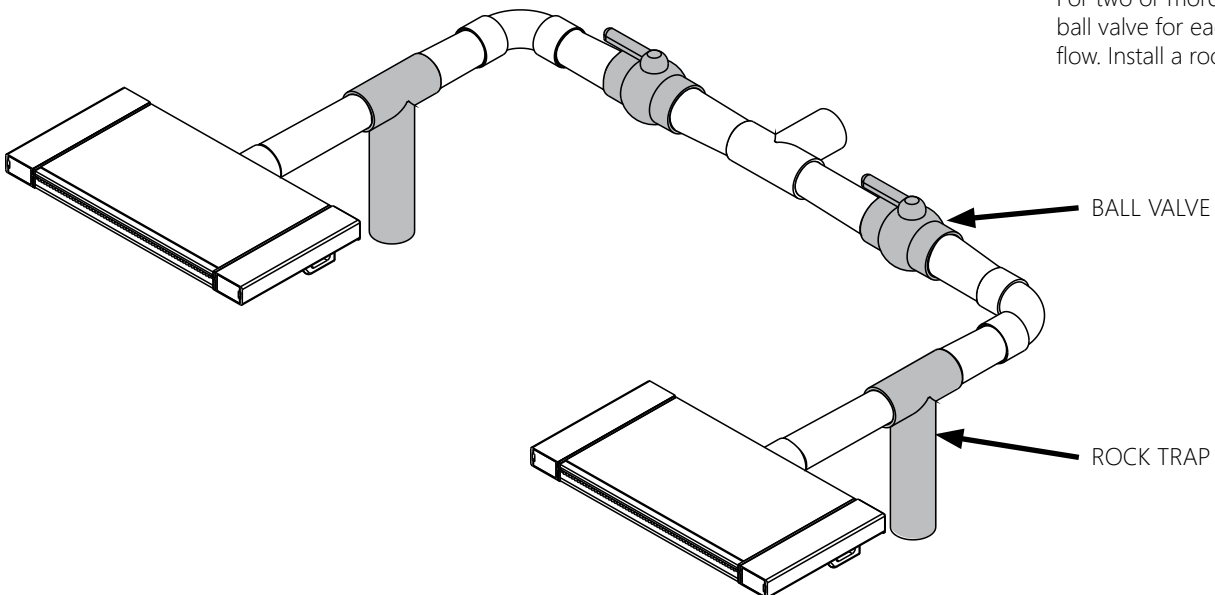

For two or more waterfalls, include a ball valve for each waterfall to control flow. Install a rock trap for each waterfall.

BALL VALVE

ROCK TRAP

8

WIRING DIAGRAM

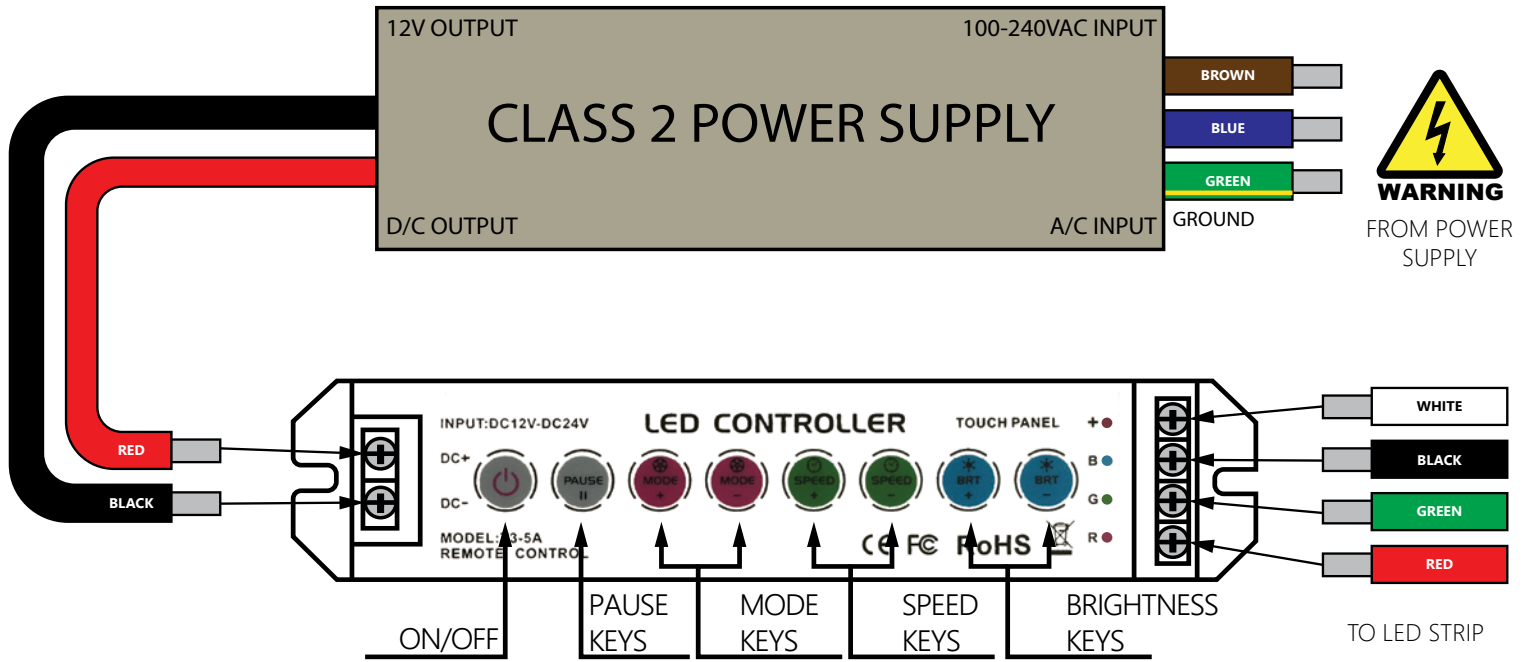

9

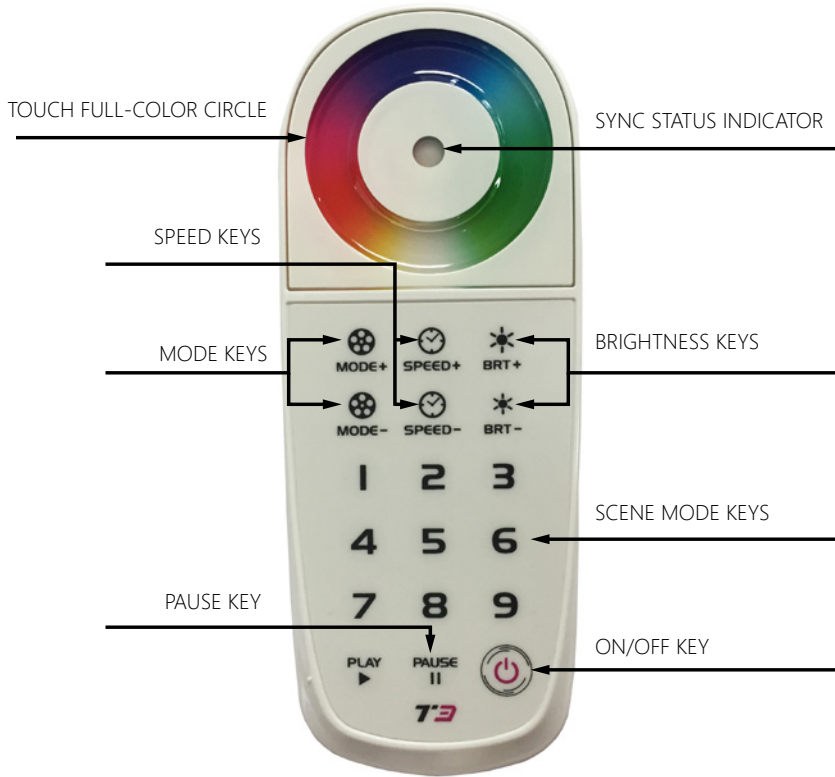

REMOTE INSTRUCTIONS

The LTECH® T3 LED RGB Controller features a user-friendly touch full-color wheel for color selection, and unique LED light for a Sync Status Indicator.

Remote functions can pause, change modes, change speed, and change the brightness. The remote comes with 32 built-in modes, or you can save your favorite modes to the Scene-Mode Keys.

KEY	DESCRIPTION
ON/OFF	Turn on and off the receiver (or LED light).
PAUSE	Press to stay on current color.
MODE	Press to select the next or previous mode.
SPEED	Press to speed up or slow down.
BRIGHTNESS	Press to increase or decrease brightness.
TOUCH CIRCLE	Touch color wheel to select a color.
SCENE MODE	Press 1-9 to load stored modes. Hold for 3 seconds to store current mode. Press Play to cycle modes.

To pair the remote with the control box press the ON/OFF key on the control box for 3 seconds until a buzzer sounds. Press any key on the remote within 5 seconds. Sync status light on remote will blink 3 times and a buzzer sounds on control box. Pairing is now complete.

AUTHORIZATION TO MARK

This authorizes the application of the Certification Mark(s) shown below to the models described in the Product(s) Covered section when made in accordance with the conditions set forth in the Certification Agreement and Listing Report. This authorization also applies to multiple listee model(s) identified on the correlation page of the Listing Report.

This document is the property of Intertek Testing Services and is not transferable. The certification mark(s) may be applied only at the location of the Party Authorized To Apply Mark.

Party Authorized To Apply Mark: Same as Manufacturer

Report Issuing Office: Atlanta GA

Control Number: 4006147

Authorized by: _____

for Thomas J. Patterson, Certification Manager



This document supersedes all previous Authorizations to Mark for the noted Report Number.

This Authorization to Mark is for the exclusive use of Intertek's Client and is provided pursuant to the Certification agreement between Intertek and its Client. Intertek's responsibility and liability are limited to the terms and conditions of the agreement. Intertek assumes no liability to any party, other than to the Client in accordance with the agreement, for any loss, expense or damage occasioned by the use of this Authorization to Mark. Only the Client is authorized to permit copying or distribution of this Authorization to Mark and then only in its entirety. Use of Intertek's Certification mark is restricted to the conditions laid out in the agreement and in this Authorization to Mark. Any further use of the Intertek name for the sale or advertisement of the tested material, product or service must first be approved in writing by Intertek. Initial Factory Assessments and Follow up Services are for the purpose of assuring appropriate usage of the Certification mark in accordance with the agreement, they are not for the purposes of production quality control and do not relieve the Client of their obligations in this respect.

Intertek Testing Services NA Inc.
545 East Algonquin Road, Arlington Heights, IL 60005
Telephone 800-345-3851 or 847-439-5667 Fax 312-283-1672

Standard(s):	UL Standard for Safety Underwater Luminaires and Submersible Junction Boxes, UL 676, Issued: 2003/6/9, Ed: 8, Rev 2013/12/19. Swimming-Pool Luminaires, Submersible Luminaires and Accessories, CSA C22.2 No. 89-1976 (R2008).
Product:	Low Voltage Class 2 LED Waterfall luminaire
Models:	25676, 25677, 25686, 25687 followed by 6 digits

ATM for Report 101237883ATL-001A

ATM Issued: 21-Oct-2014

ED 16.3.15 (1-Jan-13) Mandatory