

Brilliant Wonders®

LED WATERFALLS

INSTALLATION INSTRUCTIONS

CMP 25677 SERIES

1. PRODUCT OVERVIEW

Thank you for choosing our 25677 Series Brilliant Wonders LED Waterfall. This lighted waterfall will add a unique ambiance to your pool or other outdoor feature. In addition to our other waterfall products, this unit includes an embedded LED light that uses a wireless remote controller (Sold Separately or supplied) for convenient customer customization.

1.1 Packing List

- | | |
|---------------------------------------------|---------|
| ○ (A) LED Water Fall Unit | Qty - 1 |
| ○ (B) Screen | Qty - 1 |
| ○ (C) Rock Trap | Qty - 1 |
| ○ LED Lighting Strip – Installed at factory | Qty - 1 |
| ○ (D) Square to Round Adapter PVC | Qty - 1 |
| ○ (E) Square Plug PVC | Qty - 1 |
| ○ (G) Front access doors | Qty - 2 |

2. SAFETY

Please take a moment to read through the included important safety information. Following these safety requirements should prevent any damage to your new LED waterfall or controller.

WARNING!

Risk of Shock or Electrocution

This waterfall light must be installed by a licensed or certified electrician or a qualified pool serviceman in accordance with the National Electric Code (NEC) and all applicable local codes and ordinances. Improper installation will create an electrical hazard which could result in death or serious injury to pool users, installers, or others due to electrical shock. Always disconnect power to the light at the circuit breaker before servicing. PLEASE READ AND FOLLOW ALL INSTRUCTIONS IN THIS MANUAL.



WARNINGS AND IMPORTANT SAFETY PRECAUTIONS

Before installing this product, read and follow all warning notices and instructions that are included. Failure to follow the safety warnings and instructions can result in severe injury, death, or property damage. Installation should only be performed by a qualified professional.

Be sure that the existing electrical system prior to installation conforms to all local codes and ordinances. The electrician may need to consult the local building inspector regarding code compliance prior to installing the waterfall unit and controller.

This manual contains important information about the installation, operation, and safe use of this product. This information should be given to the owner and/or operator of this equipment. When installing and using this electrical equipment, basic safety precautions must be observed. Before attempting to install or service any equipment, ensure that all power to the electrical circuit supplying power to the system has been disconnected or turned off at the circuit breaker.

3. INSTALLATION GUIDE

3.1 Mechanical Installation

This waterfall must be installed as specified by these instructions. Please follow ALL of the instructions enclosed with this waterfall. It is recommended to keep the unit in its original packaging until the site is prepared for installation.

NOTE: USE ONLY WATER THAT HAS BEEN PROPERLY FILTERED

The Brilliant Wonders Series of CMP waterfalls are available in varying sizes. The units use 1.25 gallon of water per inch of waterfall width per minute – please size the pump accordingly (See Table 1 below).

Brilliant Wonders Waterfall Width	Minimum GPM Required for Proper Sizing
12"	15 GPM
18"	22.5 GPM
24"	30 GPM
36"	45 GPM
48"	60 GPM
60"	75 GPM
72"	90 GPM
84"	105 GPM
96"	120 GPM

Table 1: Required GPM s for proper operation of Brilliant Wonders Waterfall

Note: Brilliant Wonders Waterfalls are available in white, black, grey, dark gray and tan. Each waterfall comes with a protective tongue for the water outlet and a protective cap for the water inlet (Figure 1). These prevent debris from entering the unit during the installation process. These caps shall not be removed from the unit until the waterfall is ready to run. Failure to do so may cause permanent damage to the waterfall and void any implied warranty. In addition, each unit comes with an optional screen that can snap into the water inlet for additional filtration if desired. CMP does not recommend using the screen due to the buildup of hair or debris which can affect the performance of the waterfall.

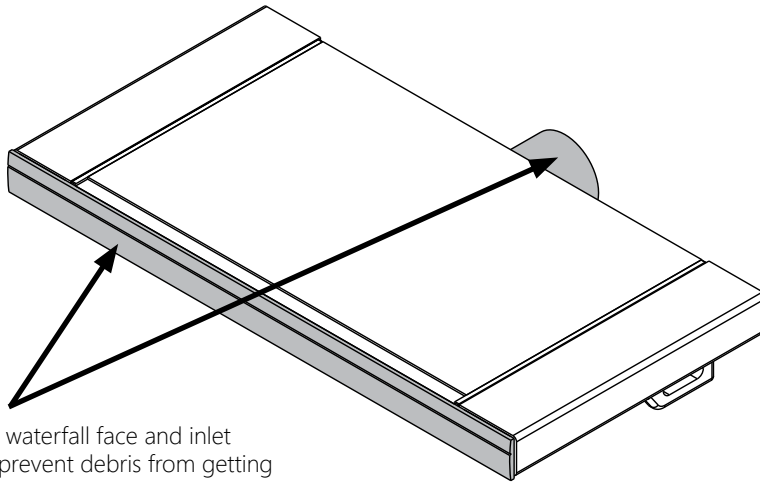

Leave protective covers on the waterfall face and inlet throughout the installation (to prevent debris from getting into the product).

Figure 1: Protective Cap and Tongue Shown on Waterfall

3.1.1 – Layout and finishing the base for a formed substrate.

The Brilliant Wonders Waterfall series has a 6” lip. With a 6” Lip, the waterfall must be installed and supported further back into the substrate. This lip must be fully supported and is recommended to be installed with the lip a minimum of 1/8” overhang from the finished surface. Depending on the installation, rebar may be used to reinforce the concrete or other substrate. If using rebar in your application, it is recommended to offset the rebar a minimum of 1 inch embedded into the substrate (typically used in concrete). When forming an area for installation, note that a plumbing and electrical notch must be provided (Figure 2). General Dimensions for the install are as follows: The foundation must be 2 inches wider than the overall width of the waterfall and the plumbing notch formed to 3 1/2” W x 3 1/2” D in the back center for adequate clearance. The electrical notch can be formed to 3” W x 3 1/2” D from either end.

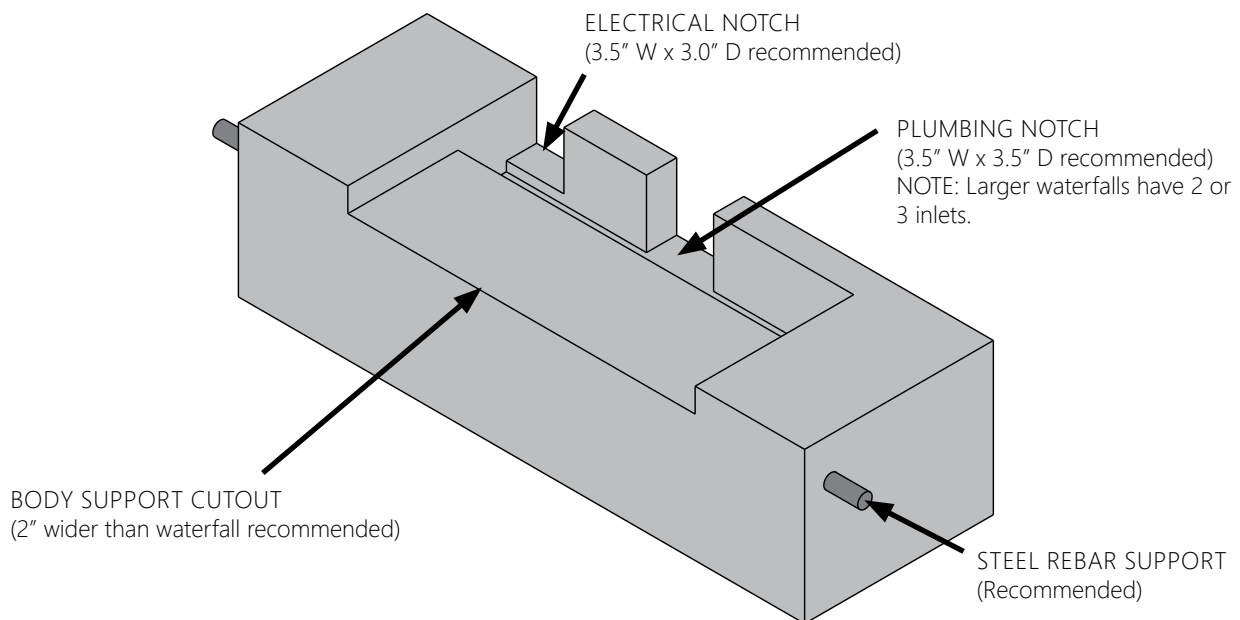

Figure 2: Concrete sample showing lip support.

3.1.2 Layout and finishing the base for a wall structure

The wall installation is very similar to the concrete/substrate installation without the forming process. The dimensional requirements for installation will be the same. In many cases, the waterfall will be supported by the wall structure where notching may not be required (Figure 3). This leaves the back open for electrical and plumbing installation. Mortar or thinset should be used to secure the waterfall in place. See section 3.1.4 for setting the waterfall.

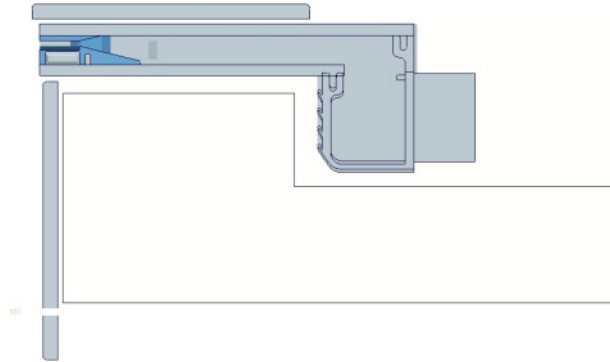

Figure 3: Bonding of Waterfall

3.1.3 Preparing the waterfall for electrical

When preparing for electrical installation, the Brilliant Wonders Waterfall is capable of accommodating conduit on either side (Figure 4). Choose which side to install the electrical PVC pipe. Refer to section 3.1.5 if you are planning on changing the electrical output side. Before securing the waterfall completely, glue the Adapter PVC fitting (D) to the back of the waterfall side to where the electrical connections will be made with PVC glue. **Gently tap the square plug (E) with a rubber mallet into the back of the opposite side for sealing. Not installing this plug may cause a water leak in the rear of the falls.**

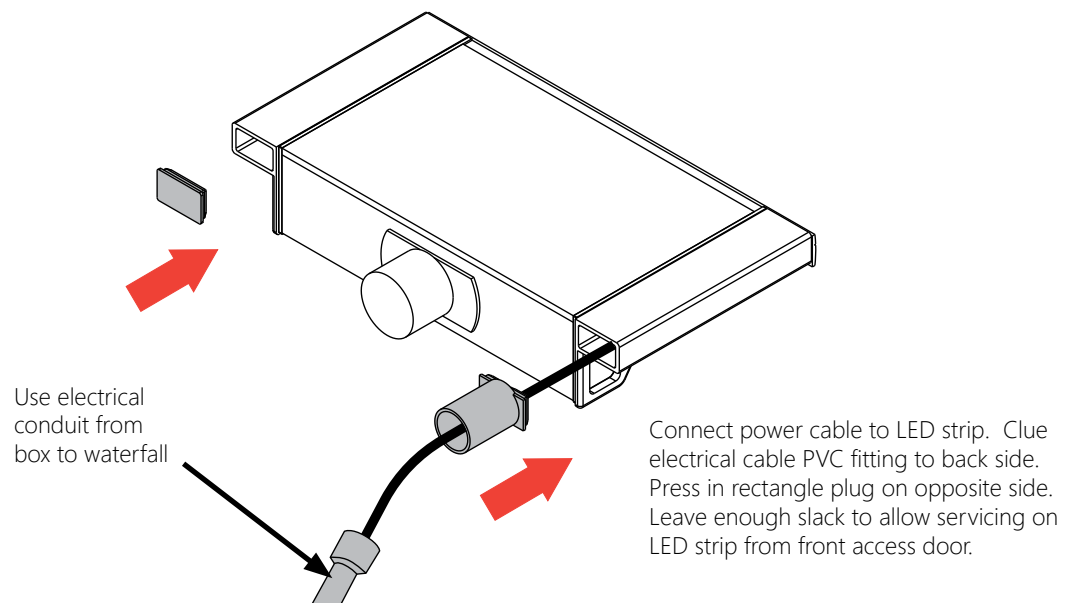

Figure 4: Electrical Wiring

NOTE: Do not stand on, drop, or step on waterfall.

3.1.4 Setting the Waterfall

For standard pool applications, the waterfall must be installed before the deck and coping. Place the waterfall in the notch cut in the bond beam or wall application. Utilize substrate material such as tile, thinset or mortar to make sure that the waterfall is level with the top of the upper edge of the bond beam. Fill the gaps around the unit and coat the face of the waterfall with concrete or similar material in preparation for the tiles or other material. Cut the tile/material to fit under the lip of the waterfall using thinset or similar substance to secure in place. Make sure to leave about 1/8" overhang of the waterfall face, after the tiles has been installed (Figure 5 & 6). Ensure the waterfall is level front to back and across the length of the fall. Complete the electrical installation and plumbing before covering the top deck.

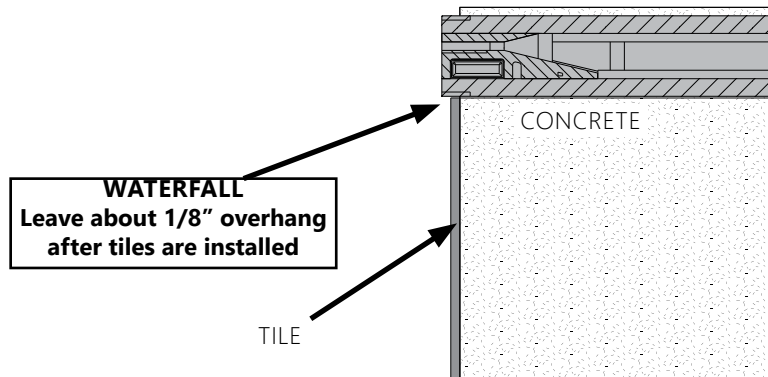
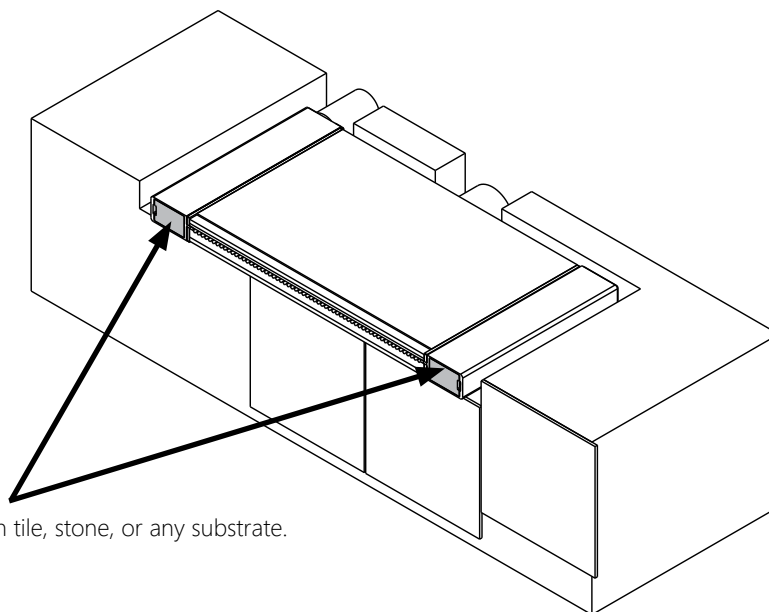

Figure 5: Waterfall flow edge overhang - Shown with tile

When installing the final facia to the waterfall whether using tile, stone or other substrate, do not cover the access doors. These will be required for servicing the unit.



Do not cover access doors with tile, stone, or any substrate.

Figure 6: Installation of the waterfall unit.

3.1.5 Plumbing the Waterfall

If multiple waterfalls are installed, a separate pump is recommended. This will also require a separate suction line to be plumbed. The dedicated pump and suction should be plumbed with a minimum of 2” schedule 40 pipe. Anti-Vortex suction covers must be used to prevent possible entrapment for each suction line that will be used in the construction. It is recommended to mount the vortex covers 18” above the bottom of the pool. A filter/strainer is also required between the pump and the waterfall in this plumbing situation. Installations requiring more than 60 gallons per minute may require two or more filters to be plumbed in parallel. A separate line with a 3-way valve must be used to balance the water between the water falls. Figure 7 below, shows the plumbing of a single waterfall unit.

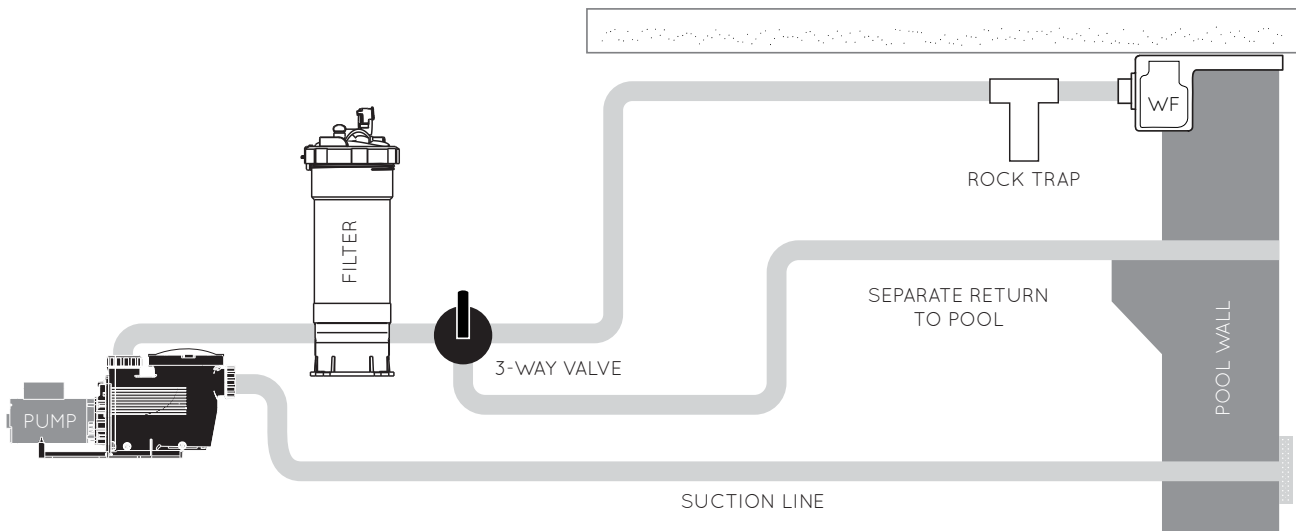

Figure 7: Mechanical plumbing design for the Brilliant Wonder's waterfall.

NOTE: It is always recommended to plumb the Brilliant Wonders Waterfall with a rock trap(C) just before the line reaches the wall.

3.1.6 Plumbing Guideline Chart

The water feed line from the pump should use a minimum of 1½” PVC pipe. The feed line should terminate near the center of the waterfall at the back of the bond beam. The Plumbing Guideline Chart in Table 2 will aid in the design of the waterfall plumbing. In addition, Figure 9 shows the recommended optimum flow pattern for a 24” waterfall.

Plumbing Guideline Chart

Use a minimum of 1-1/2” pipe

Use a minimum of 2” pipe for runs over 60’

Maximum Recommended Flow

1-1/2” Pipe	for 60 GPM
2” Pipe	for 100 GPM
2-1/2” Pipe	for 140 GPM
3” Pipe	for 225 GPM

Typical Performance at 50’ of Head

1/2 HP	26 GPM
3/4 HP	58 GPM
1 HP	68 GPM
1-1/2 HP	93 GPM
2 HP	106 GPM
3 HP	140 GPM

Table 2: Plumbing guideline charts for proper water flow.

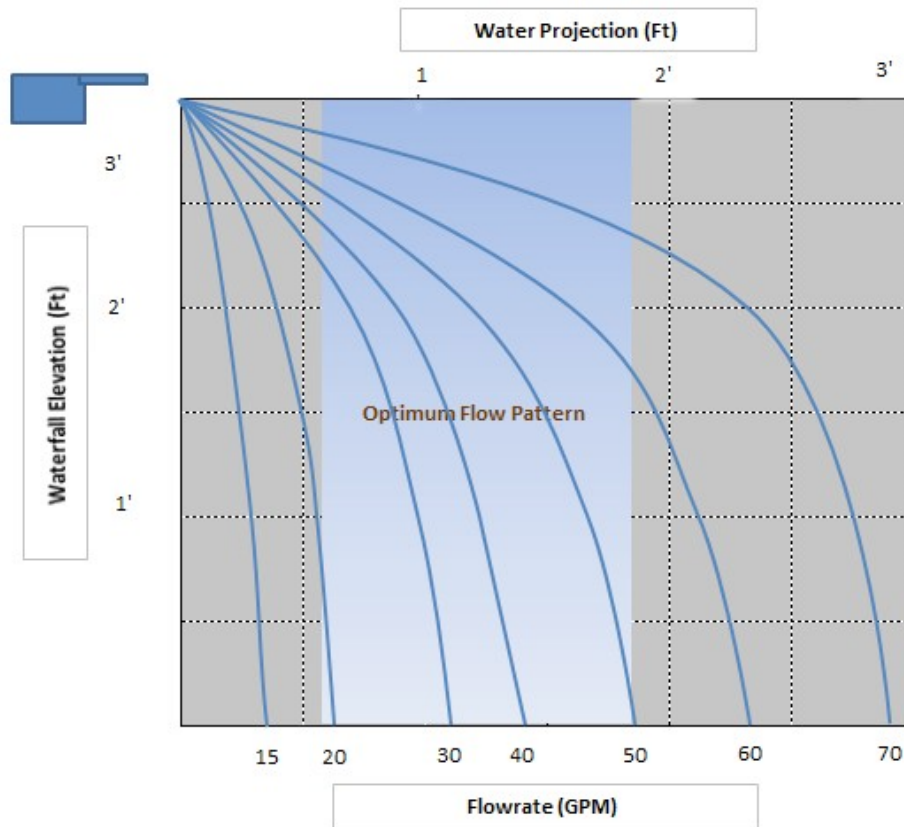

Figure 9: 24” Waterfall Performance at 3 Foot elevation

3.1.7 Balancing the Flow

It is recommended to use a 3-way valve from the return line of the pool to the waterfall to allow the flow to be regulated. The recommended location for this valve is after the filter near the equipment pad (Figure 8).

When plumbing two or more waterfalls, follow all of the previous instructions with the addition of a 2-way ball valve for each waterfall. The valve is necessary to balance the water flow between the units. Proper placement of the valve is shown in (Figure 10). (CMP ball valve part numbers are 25800-151-000 for 1½” and 25800-210-000 for 2”).

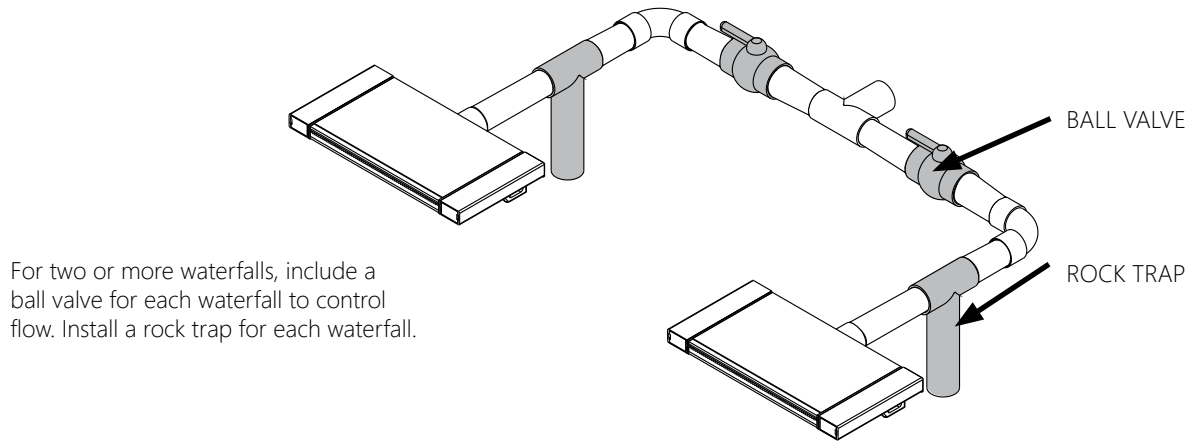

Figure 10: Multi-Waterfall Valving

NOTE: USE ONLY WATER THAT HAS BEEN PROPERLY FILTERED

4. Additional Parts List

Product Number	Product Name
25676-XX0-000	LED Waterfall (X = 1-4; width)
25650-000-000	LED controller with remote control
25650-000-100	LED Remote Control replacement
25677-130-094	Square Plug
25677-130-093	Round adapter
25677-10X-980	Front door covers (X=1-4; color)
25677-XXX-990	“L” Shaped Face Covers - colored
25577-950-000	Rock Trap

FREQUENTLY ASKED QUESTIONS

IMPORTANT: USE FILTERED WATER ONLY!

My waterfall has breaks in the sheeting, it is not a smooth flow.

1. Debris may be caught in the lip. Use the clean out tool or a thin flat tool to clear the lip. **DO NOT CUT ANY SUPPORTS**
2. Check for burrs on supports in LED waterfalls. A thin hacksaw blade may be used to carefully smooth edges as needed. **NO NOT CUT THE SUPPORTS.**
3. GPM may be inaccurate. Too little flow or too much flow through waterfall prevent proper water flow. Reference the chart in this installation guide for proper GPM.

Can the lip be cut into a custom shape or radius?

LED, Arch, and Rainfall style waterfalls may not be cut. Natural Wonders waterfalls and Streamfalls from CMP can be custom cut in the field or factor cut. Never cut to within less than 1.5" of the body.

The LED on my waterfall is only red or blue.

1. You may have the incorrect transformer. A DC transformer purchased from CMP is required to activate the controller.
2. Wires may be crossed between the controller and waterfall. Sequence top to bottom should be as follows: White, Black, Green, Red. See detailed wiring diagram on the controller instructions or quick reference card.

Do I always need to use the screen and rock trap that came with the waterfall?

We do not recommend using the screen if possible. Pet hair and other fine debris can build up over time and impede the water flow.

The rock trap is always recommended. Using the rock trap will capture debris in the pipes, and prevent it from building up in the pool. . NOTE: During installation, do not "drag" the pipes along the ground or in the dirt. This fills the pipes with dirt and the waterfall with not work correctly after installation. (Yes, we have seen this happen before!)

IF YOU HAVE ANY OTHER CONCERNS OR QUESTIONS, CONTACT CS@C-M-P.COM

