

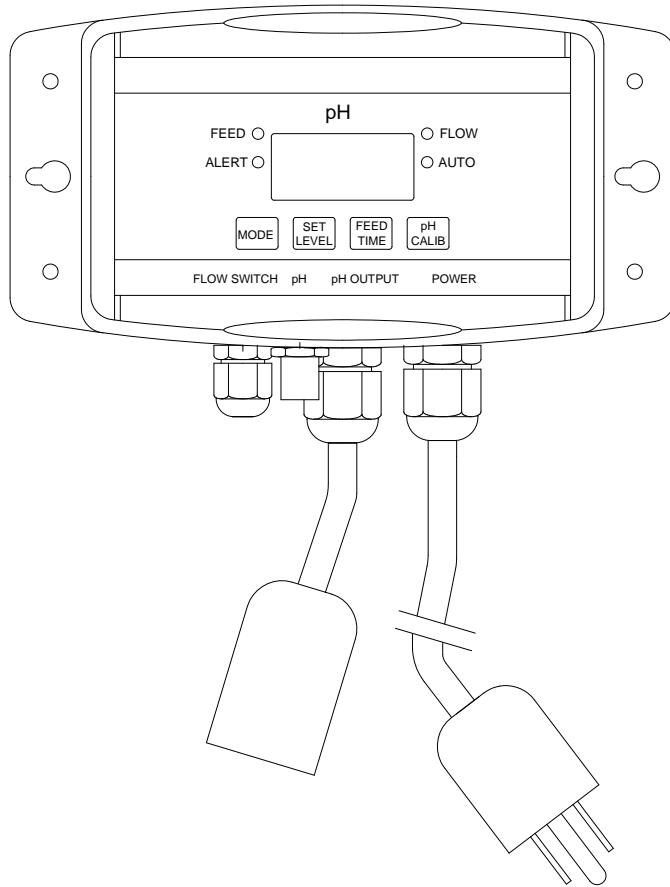

MODEL 554200 pH Digital Controller



Operating Manual

QUICK START REFERENCE

Use this section for reference - please read all safety instructions and appropriate manual sections for installation and operation instructions.

On/Off:

- press the mode button to turn the unit on.
note: 'FLOW' light must illuminate.
- press and hold the mode button to turn the unit off.
"OFF" will be displayed in the windows

To Operate:

- press and release the mode button until the "AUTO" light is lit.
Unit will now operate in the factory preset settings:
 - Set level: pH = 7.4
 - Feed times: 0.6 second feed with a 5 minute delay
 - Limits/Alerts: pH; 8.0 hi, 7.0 low

To Change Settings:

- Press and release the mode button –AUTO light off.
Note: Once the settings are changed, they will remain at those settings until they are changed again.
- Set Level: press the Set Level button until the desired set point is reached.
- Feed Time: press the Feed Time button until the desired feed time is reached.
The number represent the seconds of feed time
(all with 5 minute delays).
Range is 0.6 to 900 sec. (15 min.).
Constant feed is 'con'.

Other: See the appropriate manual sections for:

- calibrating the pH sensor
- changing function (acid/base feed)

Table of Contents

Section title	Page
--- Quick Start Reference	Inside Cover
1.0 Safety Instructions	4
2.0 Description and Specifications	
2.1 General Description	5
2.2 Specifications	6
2.3 Description of controls	7
3.0 Installation	
3.1 Locating the controller	8
3.2 Mechanical installation	8
3.3 Power access panel	8
3.3.1 Fuses	9
3.3.2 Flow Switch	9
3.3.3 Acid/Base Feed	9
4.0 Operation	
4.1 Startup	9
4.2 PH settings	10
4.3 Operating mode	10
4.4 Reset	11
5.0 Troubleshooting	12
6.0 Warranty	13
7.0 Appendix	
7.1 Water Chemistry Ranges-NSPI	14
7.2 Typical system installations	14

1.0 Safety Instruction

- A- **WARNING:** Do not shut down circulating and control system immediately after using pool, spa or hot tube. Systems must operate until water chemistry is stable. Systems must be restarted before water chemistry is out of NSPI recommended ranges or water chemistry must be manually corrected.
- B- **WARNING:** Removing power from circulating pump must also remove power from the controller. Provide a properly located outlet controlled by the circulating pump circuit.
- C- **WARNING:** Pool water must be balanced and stabilized before operating this controller. (See 'READ ME FIRST' document for further information.)
- D- **WARNING:** Use a device such as a flow switch to shut-off power from the controller in the event of pool pump or circulation failure. It is not safe to automatically dispensed chemicals into a circulating system that is not running.
- E- **WARNING:** Controller uses microprocessor. Wireless communication equipment or other electrical operated device operated in close proximity may cause inadvertent actuation of chemical feed pumps.
- F- **WARNING:** Risk of electric shock. Connect power cord to ground-fault circuit interrupter (GFCI). Contact qualified electrician if you can not verify that your installation meets local electrical codes, including grounding of water system components.
- G- **WARNING:** Do not bury cords. Locate cord to minimize abuse from lawn mowers, trimmers and other equipment. Replace damaged cords immediately. Do not use extension cords.
- H- **WARNING:** Do not install within an outer enclosure or beneath skirt of tub or spa unless so marked.

2.0 Description and Specifications

2.1 General Description

The controller is a microprocessor-based chemical automation system, which continuously monitors and maintains the pH balance in a swimming pool or spa.

The pH is displayed using sun-bright light emitting diodes. The pH levels is continuously monitored and displayed on the controller's front panel. The pH controller has been designed to be user friendly. One MODE button and three SET buttons allow the operator to easily set parameters.

The pH display range is 6.8 to 8.2 with a .1 unit resolution. The pH set point is adjustable from 7.0 to 8.0 in .1 pH steps, with a factory default set point of 7.4 pH. During a feed cycle, the feed lamp will blink when chemicals are being feed and illuminate continuously during the feed delay portion of the feed cycle. The Alert lamp will flash when the pH reading is higher or lower than the factory set limits for more than 10 minutes and prevent the feeding of pH chemicals.

The feed cycle is a timed based 'feed then delay' system. The controller has a series of fixed feed times (0.6 to 900 sec.) with associated delays as well as a constant feed mode (**con**). A feed cycle consists of a feed time plus a delay time. Example, a 30 second feed time followed by a five-minute delay would have a 5½ minute feed cycle. The chemical feeder dispenses chemical only during the feed time portion of the cycle and then waits for a delay period to allow for chemical to dispense throughout the swimming pool or spa.

Overfeed alert occurs after 120 minutes 'continuous' feed and 30 cycles in timed feed mode. Feeders will be disabled and display will flash (requiring reset).

The controller incorporates an internal non-volatile memory in which all factory default settings as well as field-modified settings are stored. The internal memory is not affected by power interruption and requires no backup battery.

The pH output is capable of handling 5 amps at 120 Volt AC. The relay output is fused and transient protected. An internal terminal strip is provided for field wiring of the controller. The internal step-down transformer has a class-two energy limiting rating to provide for electrical safety.

NOTE: *When automating any body of water, it is essential to size the feeders to reach desired levels in a relatively short period of time. Generally, automating an existing body of water with existing feeders will require the output of the feeders be increased accordingly. If feeders are unable to keep up with demand in a short period of time, automation becomes ineffective.*

2.2 Specifications

Display: pH 6.8 to 8.2
Control: pH 7.0 to 8.0
Factory default: pH 7.4

Input Power

120 Volts AC, 50/60 HZ, 3 wire grounded power cord.
GFCI source required

Output Power

120 Volts AC, 50/60 HZ, --5 amps (fused)
Two 3-wire grounded power receptacles
Terminal strip for hardwire applications.

Displays:

pH reading	– red digital LED
Flow/Power indicator	-green LED
Auto (operating mode) indicator	-red LED
Alert indicator	-red LED
Feed indicator	-green LED

(NOTE- lamps flash during the feed time and are on constant during the delay time of the feed cycle.)

Operating Temperature: 40 to 120° F

Features and Options

+ pH setting	+ pH feed/delay time	+ alert (high & low)
+ Acid/base feed	+ calibration	+ Flow switch input
+ Feed time out	+ fused outputs	

2.3 Description of Controls

Modes: The controller has two modes of operation:

- ON/OFF/Set mode
- AUTO mode- operating

To move from one mode to another simply press the MODE button.

On/off /Set mode:

- To turn the controller “on”, press the MODE button.
- To turn the controller “OFF” press and hold the MODE button for two seconds until the pH displays read “OFF”.

Release the MODE button and the controller turns off and the display goes blank.

Note: Turning the controller “OFF” using the MODE button simply turns off the controller functions, but does not turn off the power to the controller. The FLOW lamp is both the power light and a flow indicator when an optional flow switch is used.

- When Flow light is on and Auto light is off, levels can be set.

Set level button: Pressing the set level button once will display the current set level. To change the set level, press the set level button (which displays in 0.1 pH increments) until the desired level is reached.

Feed time: The feed times are displayed in seconds.

Each feed cycle includes a five (5) minute delay time.

Pressing the feed time button allows the user to select available feed times. Release the button when the desired pH feed time is reached. To set the controller in constant feed, release the button when the display reads “con”.

pH calibrate: This button allows calibration of the pH sensor to a buffer or sample tested with a test kit. Press the pH CALB button to set the pH reading to the desired pH level.

AUTO mode: This is normal operation mode. The controller operates the feeder to automatically maintain the parameters set for pH.

3.0 Installation

3.1 Locating the controller

Install the chemical pump/ feed systems as shown in manuals included with the feeders. Before installing the controller, it is important to do a site assessment to consider where and how you will mount the unit. The controller should be mounted on a wall or other surface within eight feet of the feeder, at least ten feet away from the edge of the water, and within six feet of the GFCI power source. Never mount a controller above or near an acid tank. See appendix for typical feed system schematics.

3.2 Mechanical Installation

Once the site is selected, obtain screws or anchors to securely mount the controller on the wall or a panel.

Screw slots are provided in the controller enclosure. Access to flow switch wires, acid/base changes and terminals is located on the back of the enclosure.

3.3 Power access panel

Access to terminals is through the back of the enclosure. With the controller removed from wall/panel, remove four screws holding enclosure panel to enclosure body.

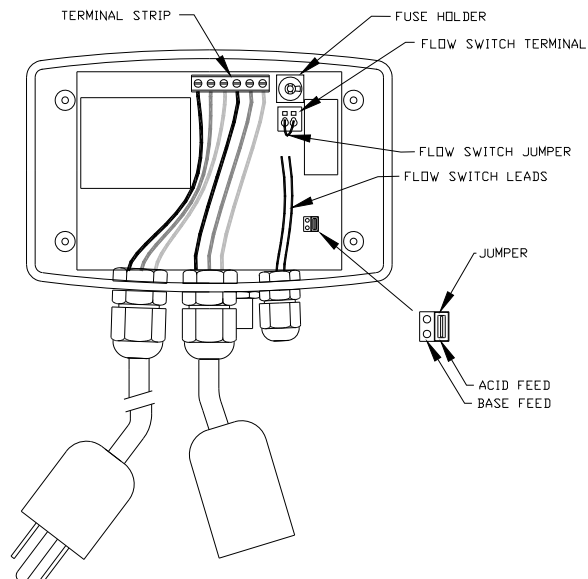

3.3.1 Fuses

Fuses protect the controller from defective feeders. They are located inside the enclosure. The fuse holders are shipped with 5 Amp fuses.

3.3.2 Flow Switch Terminal

The controller has a flow switch terminal shipped with a 'jumper' in place. The terminal must either have the jumper or a flow switch installed. The flow light on the face of the controller is also indicates the controller is connected to a live power source. If the terminal does not have a closed circuit, the controller will not turn on.

To install a flow switch, remove the jumper and attach flow switch leads. The jumper should be retained to assist in trouble shooting.

NOTE: It is recommended that an inline filter be used to help keep the flow manifold (including probes) and flow switch free from debris (see Manifold Operating Manual). Debris may obstruct flow switch and prevent the switch from functioning.

3.3.3 Acid/Base Feed Selection:

The controller has a terminal shipped with a 'jumper' used to select acid or base chemical. The jumper can be moved to change type of feed. Factory setting is acid feed. Acid feed mode will feed chemical when the pH reading is above the pH set point.

4.0 Operation

4.1 Startup

Do not add chemicals to the feeders until all start-up operations are completed. Using a DPD test kit, manually adjust and balance the pool to acceptable ranges. Automation should be used to maintain chemical levels, not to balance a pool that is out of acceptable ranges. With the controller in the OFF Mode, turn the filter pump on and check for leaks in the system and flow through the flow cell. The flow lamp will be illuminated if the controller has power, it is connected to the flow switch and there is adequate flow. If a flow switch is not attached, the flow lamp will be illuminated if there is a jumper in the flow cell terminal. It is recommended that a flow switch always be used.

4.2 pH setting

Press and release the controller MODE button until the AUTO light is off. Then select the desired set level and feed time cycle.

4.3 pH Calibration

Always calibrate using water from the sample port of the flow cell, unless using preset buffer solution. It may take up to 24 hours before the sensors acclimate to the system so recalibrate 24 hours after the first calibration. The pH sensor can drift slightly over time and calibration will offset this drift. The pH sensor should be calibrated every four to six weeks.

4.4 Operating mode

Press the MODE button until “AUTO” is lighted. This is the operational mode for the controller. The controller must be in this mode to maintain the desired parameters.

Timed feed settings: The feed lamp will flash during the feed time and be constant during the delay time of the feed cycle. Power will be supplied to feeder until set-point is reached and feed cycle is completed. If over feeding is occurring, consider shorter feed cycle.

Constant feed setting: The feed lamp will flash while feeding. Power will be supplied to feeder until set-point is reached.

The feed lamp will not activate when the pH alert lamp is on (pH is below or above the alert settings).

Low feed rates can cause the feeder to lag or feeding to be extended. A high feed rate can result in too much pH chemical being added.

To verify the feed type (acid or base) adjust pH “set” level above the pH indicated on display. The feed lamp should come on if the controller is in acid feed mode. If the controller is in base feed, the feed lamp will come on if the pH indicated is below the pH “set” level.

4.5 Reset

The controller can be reset at any time to the default factory settings.

Follow the steps below:

- A. Turn the controller 'off' by holding down the mode button
- B. Simultaneously depress and hold the 'Set Level' and 'pH Calib' buttons
- C. Turn the controller 'on' by pushing the mode button
- D. The display will read 'LD'
- E. Release the 'Set Level' and 'pH Calib' buttons
- F. Turn the controller 'off' and then 'on'.

Note: This last step is extremely important since this puts the controller back in the operating mode. If step F is not performed, the controller is in the test mode and it will not operate correctly.

5.0 Troubleshooting-

5.1 Chemicals not feeding

- * FLOW light on Controller must be illuminated. Check flow switch (manifold) if light is not on (Section 3.3.3)
- * Feeder power and time switches must be in 'ON' position. Check feeder by using alternate power source.
- * Factory setting for feed time is 0.6 sec on with 5 minute delay. Feeders may require longer feed time.

5.2 Displayed chemical level don't correspond to actual

- * Sensors (probe) is attached connector.
- * Sensors (probe) need cleaning.
- * Sensors (probe) need replacing.

5.3 Set-points not being reached or maintained

- * Factory setting for feed time is 0.6 sec on with 5 minute delay. Feeders may require longer feed time. If time is too short, set-points will not be maintained. If time is too long, overfeeding chemicals will occur. Correct time is dependent of multiple factors such as pool/spa water volume, feeder output, chemical concentration and chemical needs.
- * Controllers are designed to maintain set-points. Do not expect Controllers to make major adjustments—major changes should be done manually.
- * Pump/feeders must be large enough to reach desired set-points in a relatively short time. Automation using controllers may require larger feeder or more concentrated chemicals than system that uses continuous time controlled feeding (i.e. feeders only).

6.0 Warranty and Service-

6.1 Limited Warrenty

Rola-Chem Corporation warrants the original purchaser that this unit is free from manufacturing defects in material and workmanship from the date of the original purchase for one (1) year.

If this unit fails within the one (1) year period, it will be repaired or replaced (Rola-Chem's option) at no charge, when returned to Rola-Chem Corporation with proof of purchase receipt. This warranty does not apply to any product damage caused by improper use, accident, misuse, improper line voltage, fire, flood, lightening, earthquake or other acts of nature, or, if product was altered or opened by anyone other than qualified Rola-Chem personnel.

All expendable items- hoses, etc., are not covered under this warranty.

Heavy duty probes are warranted from the date of original purchase for one (1) year.

Rola-Chem Corporation, under no circumstances, shall be liable for any consequential damages directly or indirectly caused by this unit. Please observe all rules and regulations required by state and local regulations, building codes, health codes, OSHA, etc.

6.2 Service Procedure

For operation assistance in the United State, please call:
(800) 549-4473 or FAX (651)-653-0989
Monday thru Friday 8:00 am-5:00 pm, Central Time.

Rola-Chem Corporation has specialized knowledge and equipment to properly test your unit and help you with special problems. After talking to our service personnel, the product in need of service should be shipped with RGA#, freight prepaid, via UPS if at all possible to:

Rola-Chem Corporation
5858 Centerville Road
St. Paul, MN 55127-6804

7.0 Appendix

7.1 WATER CHEMISTRY RANGES

(These ranges are in accordance with suggested NSPI Standards for swimming pools.)

pH: 7.4 -7.6

Alkalinity: Approx. 80-120 ppm ** (parts per million)

Higher levels may be acceptable in areas where it naturally occurs in the local water supply.

Consult a pool professional in your area.

Cyanuric Acid: 0-50 ppm.

(Maintain at 30 ppm or less for best probe life.)*

TDS (Total Dissolved Solids): 300 - 2000 ppm

Calcium Hardness: 200-400 ppm

Free Chlorine: 1.0 - 3.0 ppm (> 700 millivolts ORP)

*20-30 ppm of cyanuric acid provides approx. 95% of the shielding effect for chlorine.

**When using tri-chlor, recommended alkalinity is 95-125 ppm.

7.2 Typical System Installations

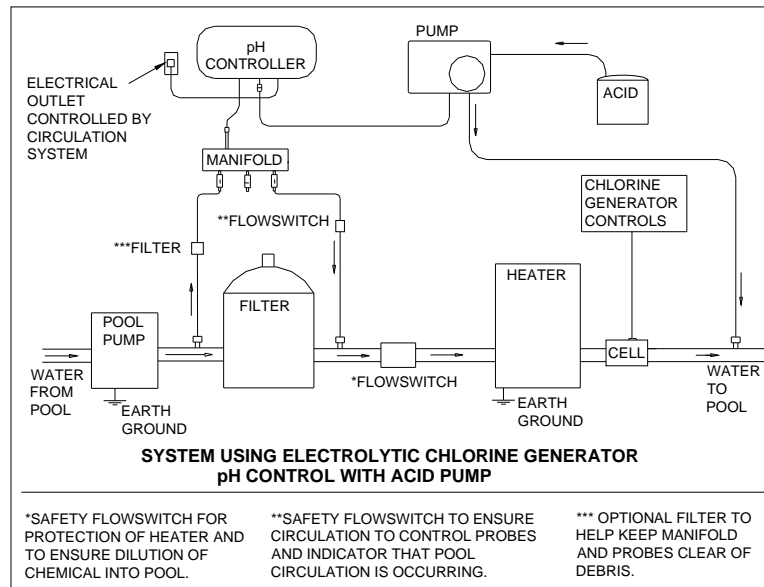

-- NOTES --

-- NOTES --