

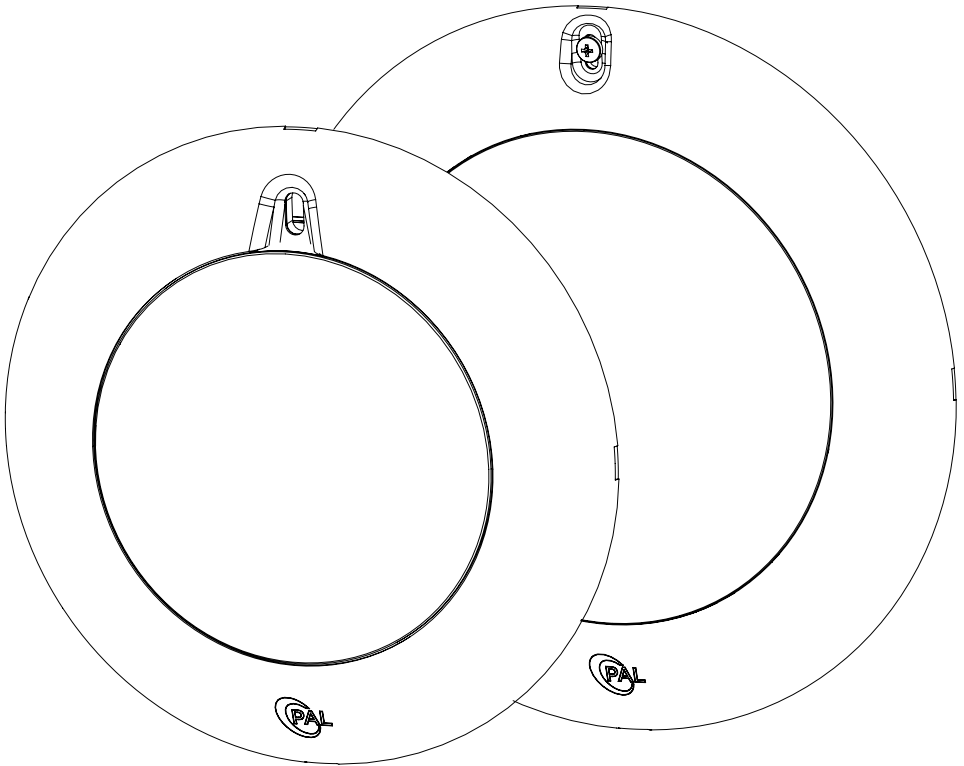

LIGHTING



# EVENGLOW

POOL AND SPA LIGHT  
INSTALLATION MANUAL  
FOR REPLACEMENT

# CONTENTS

PAGE	
2	Guides and Warnings
3	Nicheless Installation
6	Connecting Light
7	Connecting to driver
8	Troubleshooting
8	Terms and Conditions

## GUIDES AND WARNINGS

### Tools Required:

Phillips Head No. 2 Screw Driver

### IMPORTANT INFORMATION:

#### **DO NOT CONNECT THIS 12V LIGHT DIRECT TO A 120V CIRCUIT.**

1) Ensure that the electrical system for your pool conforms with all the requirements of the National Electrical Code (NEC) and all relevant local codes and ordinances.

2) This 12V Underwater Light must be installed in accordance with the National Electrical Code by a Certified Electrician or a Qualified Pool Technician. NOTE: No Bonding Terminal is required on the forming shell since the fixture is an all plastic construction and complies with NEC article 680 Requirements.

3) This Underwater light is designed for use with the PCR-4 AND PCR-2D UL Listed Class 2 LED Driver.

The Junction Box and the low voltage transformer is located at least 4 (four) inches (10.16 cm) above ground level or eight (8) inches(20.3 cm) above maximum water level, whichever is higher. The Junction Box must be at least 48 inches (1.22 m) from the edge of the pool.

To be certain that the pool or spa electrical system meets all applicable requirements, the electrician should also consult the local building department.

#### **CANADIAN INSTALLATION**

Be sure the electrical system of your pool conforms with the following requirements of the Canadian Electrical Code (CEC), CSA C22.1 and all local codes and ordinances. A licensed or certified electrician must install the electrical system to meet or exceed those requirements before the light and (fixture-housing) is installed. Failure to do so could result in death or serious injury to service technician, pool users or others due to electrical shock.

# POOL & SPA LIGHT REPLACEMENT INSTALLATION

## Replacing existing Large Pool Light

### Pre-Installation Guidelines

Risk of Electrical Shock or Electrocutation! This underwater light must be installed by a licensed or certified electrician or a qualified pool professional in accordance with the NEC and all applicable local codes and ordinances. Improper installation will create an electrical hazard which could result in death or serious injury to pool users, installers or others due to electrical shock, and may also cause damage to property. Always disconnect the power to the pool light at the circuit breaker before servicing the light. Failure to do so could result in death or serious injury to service technician, pool users or others due to electrical shock.

Please check that the pool and spa meets the requirements of the current NEC and all local codes and ordinances. A licensed or certified electrician must install the electrical system to meet or exceed those requirements before the underwater light is installed. Some of the requirements of the NEC which the pool's electrical system must meet are as follows:

- The lighting circuit has a Ground Fault Circuit Interrupter (GFCI) for line voltage models and has an appropriately rated circuit breaker.
- The Junction Box (or for 12V models, the low voltage transformer) is located at least eight (8) inches (20.3 cm) above ground level and at least 48 inches (1.219 m) from the edge of the pool.
- The light fixture and all metal items within five (5) feet (1.524 m) of the pool are properly electrically bonded.
- The wet niche is properly electrically bonded and grounded via the No. 8 AWG ground connector located at the rear of the niche.
- Make sure that the swimming pool's electrical system meets all applicable requirements, the electrician should also consult the local building department.

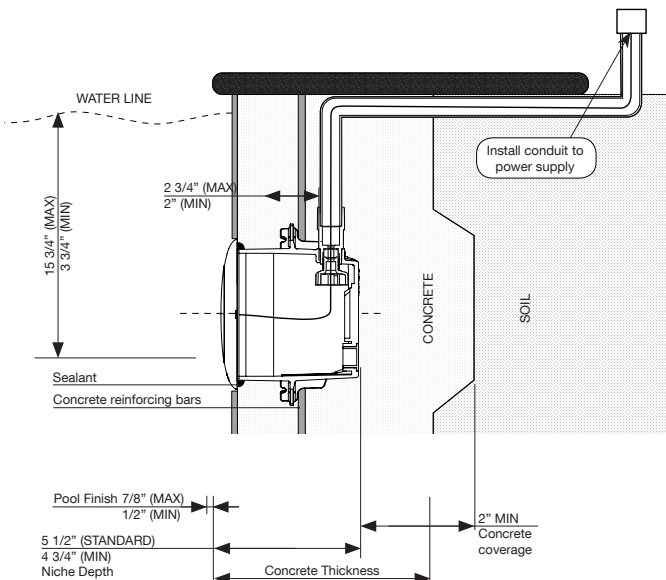

## Pool and Spa Installation Guidelines

The following instructions describe how to remove and install the new PAL Evenglow Pool and Spa light.

Please check that the pool and spa meets the requirements of the current NEC and all local codes and ordinances. A licensed or certified electrician must install the electrical system to meet or exceed those requirements before the underwater light is installed. Failure to do so may cause Electric Shock and damage to property.

1. **WARNING!** Switch off main electrical switch or circuit breaker and the switch which operates the new Evenglow Pool and Spa light.
2. To remove current old light fixture assembly from the pool. Undo the pilot screw at top of light and remove the light assembly from the niche and place it on top of the pool coping.
3. Cut the cord from back of light assembly.
4. Remove Junction Box cover, disconnect the light fixture wires and pull the cord through the conduit. Make sure you have connected new light cable when pulling old existing cable through the conduit.
5. Make sure you Leave at least four (4) feet of cable to coil inside Niche allowing for service once pool is full of water.
6. Cut the cord at the Junction Box, leaving at least size (6) inches of cord to make connections.
7. Strip outer cable jacket to expose the four copper conductors (+W, R, G, B) and be careful not to damage the copper when doing so.
8. Connect the four light wires (+W, R, G, B) to the corresponding light circuit inside the driver.
9. For two wires; connect the Brown wire (+) and Blue wire (-) to either a 12V AC Transformer or 12V DC power supply.
10. Install the PAL Evenglow Large light assembly into the pool niche. Be sure to insert the hook on the light into the SLOT on the lower part of the niche.
11. Insert mounting screw into top of light and secure to thread in Niche. Do not overtighten screw.
12. Use only the provided mounting screw with this Evenglow light. This mounting screw electrically grounds the stainless steel dress ring to the bonded niche. Failure to use the screw provided could create an electrical hazard which could result in death or serious injury to pool users, installers or others due to electrical shock.

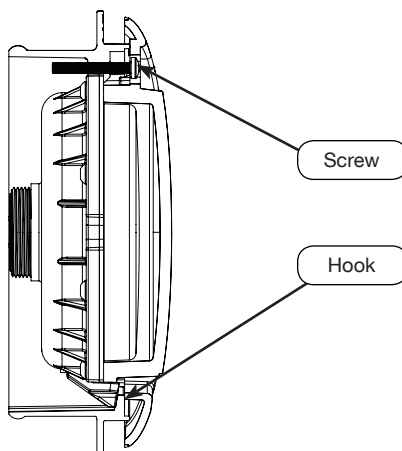

13. Finally switch on the main switch or circuit breaker to the system, and the switch that operates the Evenglow underwater light itself. The light should illuminate when power is applied. If not recheck the installation steps starting with Step 1.

# CONNECTING TO DRIVER

## PAL COLOR TOUCH DRIVER

The PAL-EGM/EGL is powered by the PAL PCR-4 Class 2 LED Driver or PCR-2D that is controlled with the PCT-1 Wireless transmitter.

Refer to PCR-4 or PCR-2D for Detailed Installation Instructions.

PCR-4 Driver  
50 watts (PCR-4U-CL)

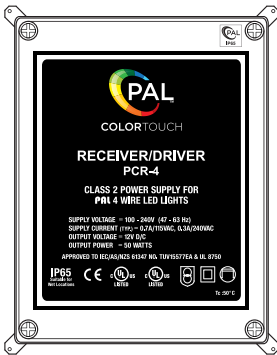

PCR-2D Driver  
16 watt version (PCR-2D-16)  
35 watt version (PCR-2D-35)  
55 watt version (PCR-2D-60)

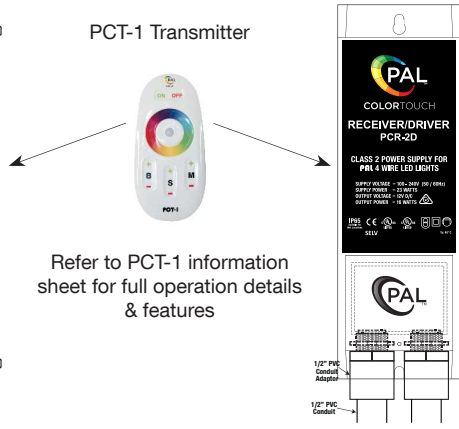

### Cloning Feature

DIP 1	DIP 2	CLONING DIP SWITCH SETTING
OFF	ON	JANDY
OFF	OFF	PENTAIR
ON	OFF	HAYWARD
ON	ON	PAL

### NOTE:

- Must turn off power before making DIP switch selection.
- When synching PAL lights to other OEM lights, static colors will match but color change mode timing may vary.
- If the PAL Lights are to be used with Automation, do not use the handheld remote control and disconnect the Wi-Fi module from the board if so equipped.
- If the Automation does not turn the PAL lights on or off and there is power to the driver, press the S1 button one time to turn on the PAL Driver.
- Note that the PAL features of infinite color selection and dimmability are not available while in Cloned mode.

# TROUBLESHOOTING

## Model: 4 Wire Evenglow Light

ISSUE	REASON	ACTION
Light not turning on (1)	Faulty Globe.	Replace Globe.
Light not turning on (2)	Faulty Driver.	Check Driver output under load using a multimeter. 12volts DC.
Light not turning on (3)	Cut Cable.	Check the voltage at light using a multimeter.
Light not turning on (4)	Driver not connected to GPO or switched on.	Check Driver is connected to power, check power indicator LED is lit on your Driver. If still no indicator light, send back to PAL for repair.
Light not turning on (5)	Faulty LED Driver inside control box.	Push the test button inside control box, if lights still doesn't turn on then send product back to PAL.
Lights out of sync (1)	Light incorrectly wired to control box.	Check color wire sequences connecting to control box.
Lights out of sync (2)	Lights incorrectly wired to LED lamp.	Check color sequences to LED lamp terminal block inside the light.

# TERMS AND CONDITIONS

## PAL PRODUCT WARRANTY DETAILS

The PAL product is guaranteed against defects in materials and/or workmanship, under normal domestic use for (12) twelve months.

Except as otherwise provided for by law, this guarantee becomes invalid if in the opinion of the Company the product has been misused, abused, damaged in transit, incorrectly installed, or connected to an electrical supply not corresponding with the products specification or a non-approved PAL power supply.

The Company is not responsible for forwarding freight charges or losses in transit.

If any part of the product proves to be defective within the warranty period, the defective part will be repaired or replaced, free of charge and at the discretion of Bellson Electric.

Bellson Electric shall not be liable for any loss of profits or any consequential, indirect or special loss, damage or injury of any kind whatsoever arising directly or indirectly from Bellson Electric products. This limitation does not apply to any liability under the Australian or New Zealand consumer legislation.

PLEASE REGISTER YOUR PRODUCT WARRANTY DETAILS ONLINE AT:

[www.bellson.com.au/register.htm](http://www.bellson.com.au/register.htm)

OR You MUST retain some proof of purchase to provide evidence of the DATE of the original purchase.