

Raypak[®]
A Rheem[®] Company

Protégé™ VSP

ABOVE GROUND POOL PUMPS



Protégé™ Series

ABOVE GROUND POOL FILTERS & PUMPS

Protégé AGP

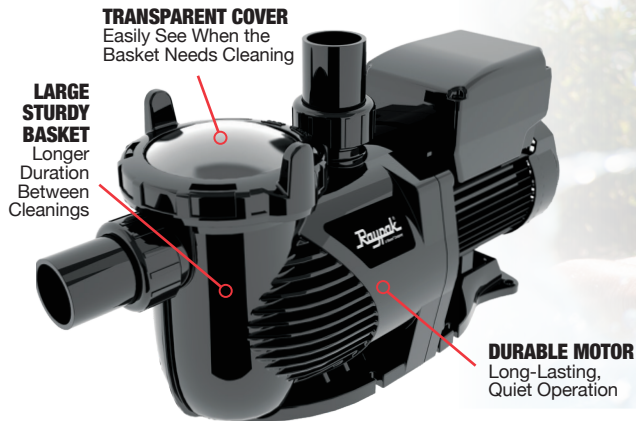

About the Protégé VSP

The “VS” in our new Protégé VSP stands for “variable-speed”, denoting a high-performance, yet high-efficiency pump for today’s energy and cost-conscious world.

The pump is heart of your swimming pool’s circulation system, pushing water through the filter to remove debris or impurities. The VSP’s PMM (permanent-magnet motor) Technology allows the pump to achieve efficiency over single speed pumps. Single-speed pumps are either off, or consuming energy at 100% of their capacity. The VSP has the capability of modulating and only working as hard as is needed based on the conditions. It can lower or raise operating speed and flow rate as needed reducing overall energy consumption and cost.

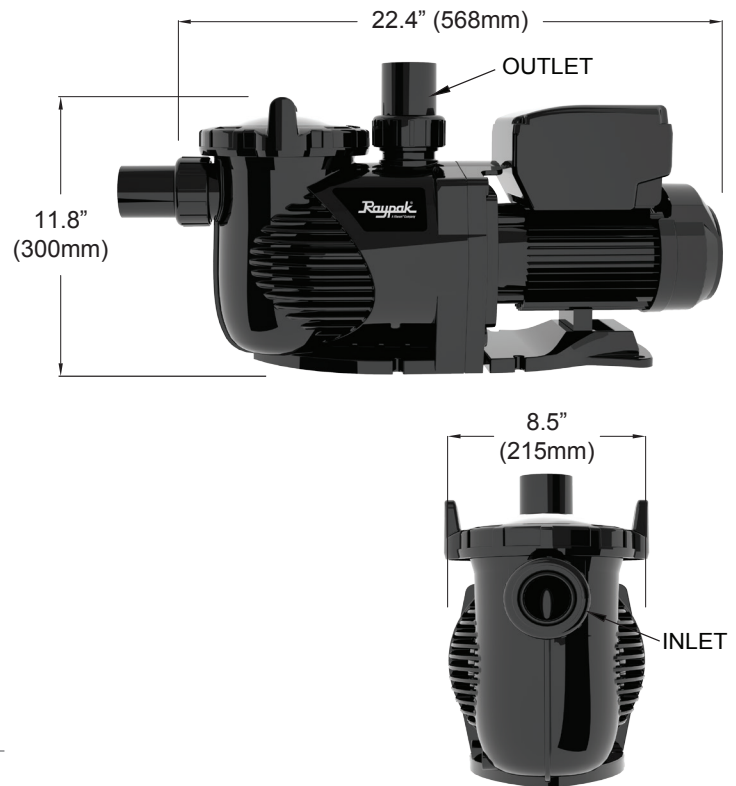

Product Specifications

Model	Input Power	Power (HP)	RPM	Voltage/Frequency	Max Load	Connection ID/OD
RPVSP1	1.30kW	1.5	800-3400	220/240V-50/60Hz	5.9-5.4A	1.5"/2"