

**Raypak**<sup>®</sup>  
A Rheem<sup>®</sup> Company

# Protégé™ AGP

ABOVE GROUND POOL PUMP



## Protégé™ Series

ABOVE GROUND POOL FILTERS & PUMPS

# Protégé AGP

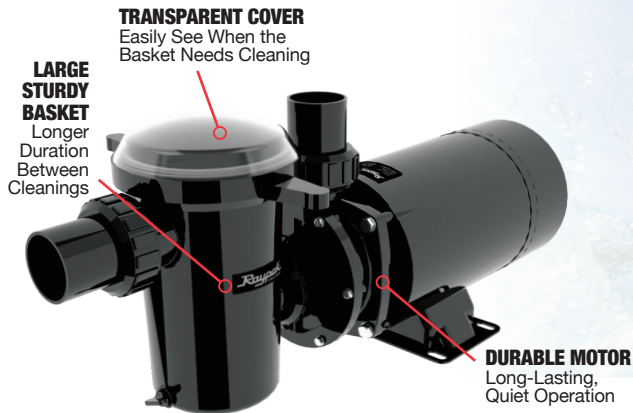

## About the Protégé AGP

The Protégé AGP is reliable and durable high-performance above-ground pool pump, designed for efficiency and quiet operation. The Protégé AGP is equipped with UV and temperature protection, safeguarding the pool pump from direct sunlight and hot water temperatures. It comes with a standard 1.5" suction and discharge port for continual filtration of your pools water.

The Protégé AGP is vital to your swimming pool's filtration system, ensuring steady and reliable flow to keep your pool clean and clear for enjoyment all year long.

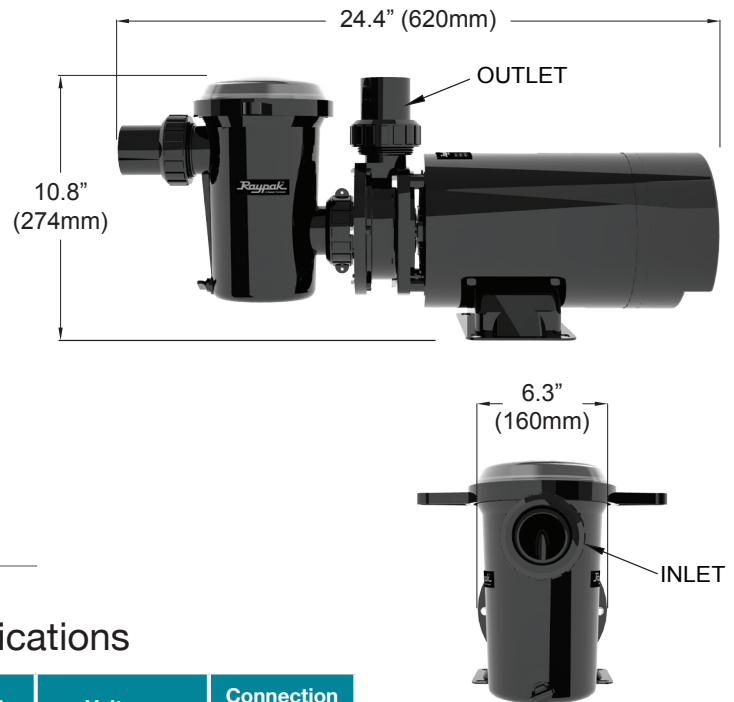

## Product Specifications

Model	Input Power	Power (HP)	Speed	Voltage	Connection Size
RPAGP75	0.55kW	0.75	Single	110/115V-60Hz	1.5"
RPAGP100	0.75kW	1.0	Single	110/115V-60Hz	1.5"
RPAGP102	0.75kW (Max)	1.0	Dual	110/115V-60Hz	1.5"
RPAGP150	1.1kW	1.5	Single	110/115V-60Hz	1.5"
RPAGP152	1.1kW (Max)	1.5	Dual	110/115V-60Hz	1.5"