

English

174
PO

IMPORTANT SAFETY RULES

Read, understand, and follow
all instructions carefully before
installing and using this product.

Deluxe Pool Maintenance Kit

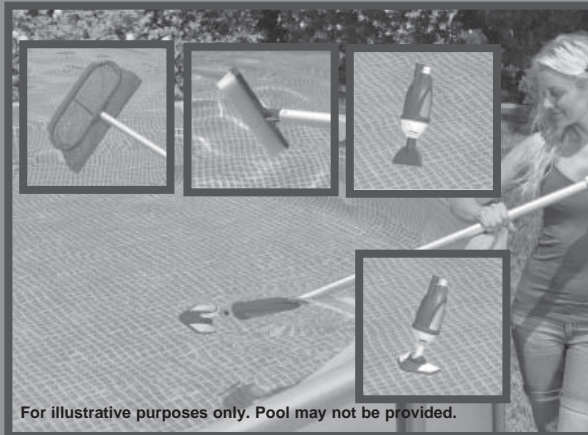

For illustrative purposes only. Pool may not be provided.

Don't forget to try these other fine Intex products: pools, pool accessories, inflatable pools and in-home toys, airbeds and boats available at fine retailers or visit our website.

Due to a policy of continuous product improvement, Intex reserves the right to change specifications and appearance, which may result in updates to the instruction manual without notice.

INTEX®

IMPORTANT! DO NOT RETURN PRODUCT TO STORE

To purchase parts and accessories or to obtain non-technical assistance, Visit

www.intexcorp.com

For technical assistance and missing parts call us toll-free (for U.S. and Canadian Residents):

1-800-234-6839

Monday through Friday, 8:30am to 5:00pm Pacific Time

174-*PO-R0-1805

OWNER'S MANUAL

TABLE OF CONTENTS

Warnings.....	3
Parts List & Reference.....	4
Pool Vacuum Set-Up Instructions.....	5-8
Pool Vacuum Operating Instructions.....	9
Hand-held Skimmer Assembly & Operating a Instructions and Long Term Storage.....	10

IMPORTANT SAFETY RULES

Read, Understand and Follow All Instructions Carefully Before Installing and Using this Product.



WARNING

- Do not permit children to use this product. Adult use only.
- Do not operate the filter pump while the pool is occupied or in use.
- Strong suction. Keep hands and hair away from the vacuum body suction opening when the filter pump is operating.
- Turn off or unplug the filter pump before adjusting, cleaning, servicing, removing or changing components.
- Remove all maintenance items when the pool is in use.
- Keep telescoping aluminum handle away from any overhead power lines.

FAILURE TO FOLLOW THESE WARNINGS MAY RESULT IN PROPERTY DAMAGE, ELECTRIC SHOCK, ENTANGLEMENT OR OTHER SERIOUS INJURY, DROWNING OR DEATH.

These product warnings, instructions and safety rules provided with the product represent some common risks of water recreation devices and do not cover all instances of risk and danger. Please use common sense and good judgement when enjoying any water activity.

Filter Pump Flow Rate Requirement:

800 - 4000 gallons/hour (3028 - 15140 liters/hour)

SAVE THESE INSTRUCTIONS

PARTS REFERENCE

Before assembling your product, please take a few minutes to check the contents and become familiar with all the parts.

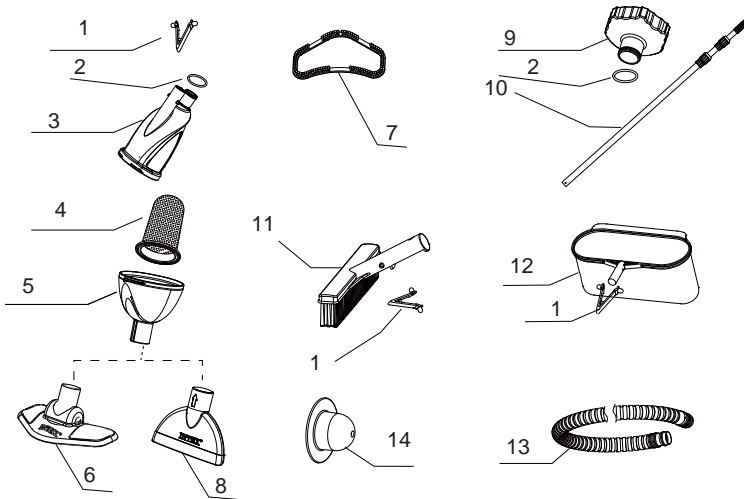

COMMON	DESCRIPTION	QTY.	SPARE PART NO.
1	SPRING (PREINSTALLED IN 3, 11 & 12)	3	10794
2	HOSE SEAL (PREINSTALLED IN 3 & 9)	2	10134
3	VACUUM BODY (SPRING & HOSE SEAL INCLUDED)	1	11431A
4	DEBRIS BAG	1	10788A
5	VACUUM BODY COVER	1	11443
6	VACUUM HEAD (BRUSH INCLUDED)	1	11445A
7	BRUSH	1	11446A
8	FLAT VACUUM NOZZLE	1	11444A
9	ADAPTOR (HOSE SEAL INCLUDED)	1	11447A
10	TELESCOPING ALUMINUM SHAFT	1	10798A
11	BRUSH HEAD (SPRING INCLUDED)	1	11073A
12	SKIMMER NET (SPRING INCLUDED)	1	10796A
13	VACUUM HOSE	1	10797
14	FLOW REDUCTION ADAPTER	1	11237

NOTE: Drawings for illustration purpose only. Actual product may vary. Not to scale.

SAVE THESE INSTRUCTIONS

SETUP INSTRUCTIONS

- 1** Insert the debris bag (4), into the vacuum body (3).

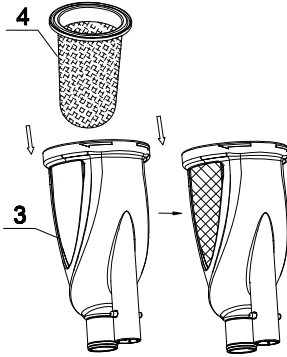

- 2** Install the vacuum body cover (5) onto the vacuum body (3). Turn the cover (5) clockwise to securely lock it to the vacuum body (3).

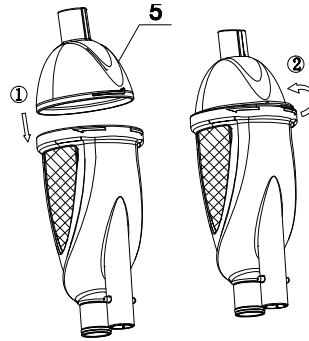

- 3** Attach the desired cleaning head accessory to the vacuum body cover:

- Use the flat vacuum nozzle (8) to pick up heavy and/or mid-large particles such as sand, stones, etc; and also to maneuver around tight corners or pool edges.
- Use the vacuum head brush (6) to pick up fine and/or small debris such as dust and dead algae on the bottom of the pool floor.

Note: Make sure the ridge on the vacuum body cover (5) attachment end matches the groove on the flat vacuum nozzle end or vacuum head brush end.

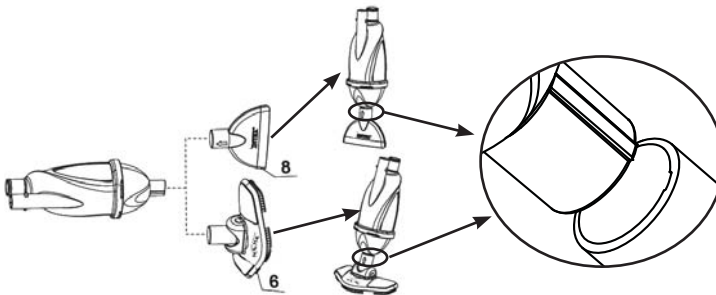

SETUP INSTRUCTIONS (continued)

4

Attach one end of the vacuum hose (13) to the vacuum body (3). Make sure the vacuum hose end is covering the hose seal (2) on the vacuum body.

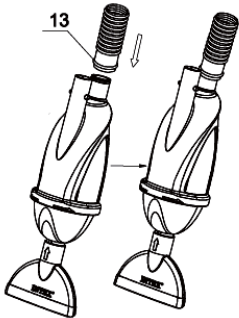

5

Squeeze the spring tips (1) and attach the telescoping aluminum shaft (10) onto the vacuum body (3). Make sure the shaft is securely attached by checking the spring "pops" into the pre-drilled holes. Adjust the length of the shaft by unlocking, extending and locking each section accordingly.

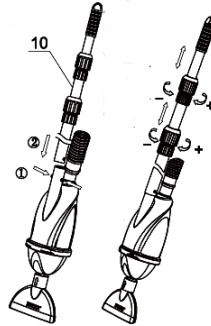

6

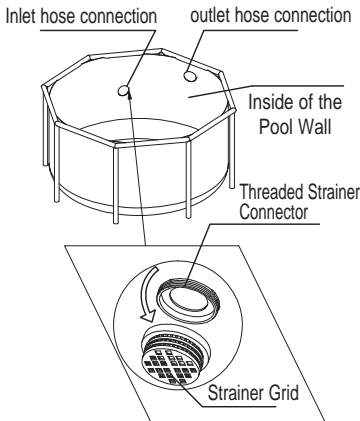

7

Screw the adaptor (9) to the threaded strainer connector, from inside of the pool.

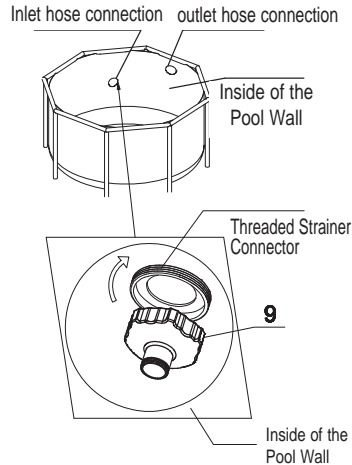

SETUP INSTRUCTIONS (continued)

8

Place the whole assembled product into the water.

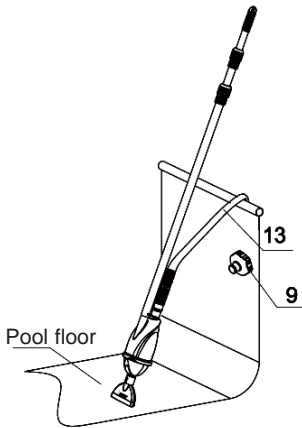

9

Fill up the vacuum hose (13) with water by submerging the hose into the water slowly to remove all of the entrapped air from the hose. **TIPS: Starting from the end closest to the vacuum body, submerge the vacuum hose vertically into the water slowly, section by section.**

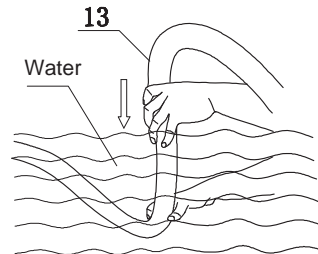

10

When the vacuum hose (13) is filled with water, the water will flow out from the other end of the hose.

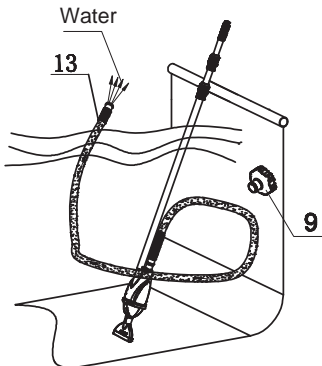

11

Quickly attach the other end of the vacuum hose (13) filled with water to the adaptor (9).

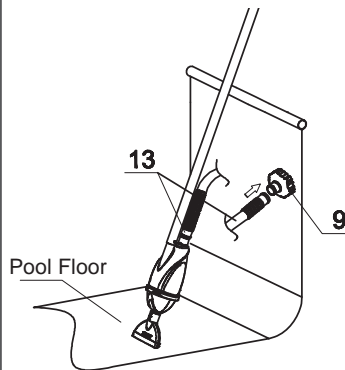

SETUP INSTRUCTIONS (continued)

12

Turn on the pump. To eliminate air trapped in the hose or in the pump system, turn the air release valve (if any) 1-2 turns to allow air to escape. Refer to the pump owner's manual for details. **IMPORTANT:** Never run the pump dry as the motor may overheat and damage the pump. Keep the vacuum body under the water at all times during use, or the air will come into the hose, causing the pump to run dry and damaging the pump.

IMPORTANT

- Release all the air from the hoses and filter pump before use.
- Keep the vacuum body under the water at all times during use.
- Remove the vacuum body assembly, hose and adaptor, and replace the strainer grid when running the filter pump only and when the pool is not in use.
- Check and empty the debris bag regularly during and after each use.

The pool vacuum is now ready to use.

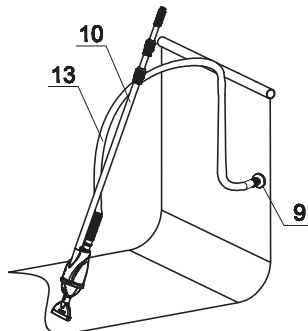

13

If the debris bag (4) is full and experiencing low suction when vacuuming, turn off the pump and bring the vacuum body assembly out of the water. Empty the debris bag by reversing steps 1 to 3. Make sure the debris bag and vacuum body are clean before replacing the components back. Repeat steps 1 to 3 to replace all components back. **NOTE:** if experiencing low suction and the debris bag is clean, make sure the pump is running, there is no blockage and/or air trapped along the water circulation line.

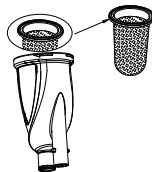

SAVE THESE INSTRUCTIONS

POOL VACUUM OPERATING INSTRUCTIONS

1. The filter pump is an airtight system. To eliminate air trapped in the hose or in the pump, turn the air release valve (if any) 1-2 turns in a counter-clockwise motion to open the valve. Refer to the pump owner's manual for details.
2. When water starts flowing out of the air release valve hole, screw in the air release valve back into the filter housing cover. Do not over tighten the valve.
3. Connect the filter pump to the power outlet and turn ON the pump.
4. In soft gentle strokes "sweep" the entire bottom surface of the pool liner until it's clear of debris.

IMPORTANT

If you experience low suction on the vacuum, check that all of the air has been removed from the hose. If you still have a low suction problem, please review the Troubleshooting Guide for your filter pump under "Filter pump does not pump water or flow is very slow". Also, check that the debris bag and filter pump cartridge are clean.

5. Make sure the filter pump is turned off, and disconnect the power cord from the electrical outlet. Remove the pool vacuum from the pool.
6. Using the Set-Up instructions in reverse, disassemble the vacuum cleaner. Clean the debris bag if necessary.
7. Store the pool vacuum in an area where it will not be a safety hazard.

HAND-HELD SKIMMER NET ASSEMBLY & OPERATING INSTRUCTIONS

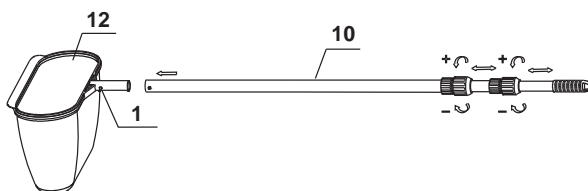

1. The hand-held skimmer net uses the same handle as the pool vacuum.
2. The skimmer net (12) has a plastic spring that connects to the end of handle. Align the plastic spring located inside the net with the holes drilled in the handle. Gently squeeze together the plastic spring tips so that the handle slips onto the net and the spring "POPS" into the pre-drilled holes.
3. Gently sweep the surface of the pool with the skimmer net removing floating leaves, etc.

HAND-HELD BRUSH ASSEMBLY & OPERATING INSTRUCTIONS

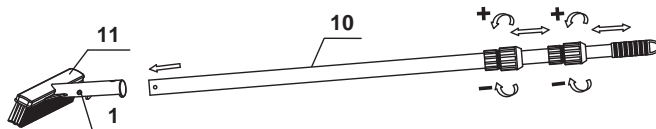

1. The hand-held brush uses the same handle as the pool vacuum.
2. The brush head (11) has a plastic spring that connects to the end of handle. Align the plastic spring located inside the brush head with the holes drilled in the handle. Gently squeeze together the plastic spring tips so that the handle slips onto the brush head and the spring "POPS" into the pre-drilled holes.
3. Gently sweep the entire side and bottom surfaces of the pool liner until it's clear of debris.

LONG TERM STORAGE

1. Make sure the filter pump is turned off and disconnect the power cord from the electrical outlet.
2. Using the Set-Up instructions in reverse, disassemble pool vacuum, hand-held skimmer or hand-held brush.
3. Clean and air dry all the accessories and parts thoroughly.
4. The original packaging can be used for storage. Store in a dry, cool storage location.