

**IMPORTANT  
SAFETY RULES**  
Read, understand, and follow  
all instructions carefully before  
installing and using this product.

# Krystal Clear™ Model 635T Filter Pump



For illustrative purposes only.

**Don't forget to try these other fine Intex products: pools, pool accessories, inflatable pools and in-home toys, airbeds and boats available at fine retailers or visit our website.**

**Due to a policy of continuous product improvement, Intex reserves the right to change specifications and appearance, which may result in updates to the instruction manual without notice.**



**IMPORTANT!  
DO NOT RETURN PRODUCT TO STORE**

To purchase parts and accessories or to obtain non-technical assistance, Visit

**[www.intexcorp.com](http://www.intexcorp.com)**

For technical assistance and missing parts call us toll-free (for U.S. and Canadian Residents):

**1-800-234-6839**

**Monday through Friday, 8:30am to 5:00pm Pacific Time**

## TABLE OF CONTENTS

<b>Warnings.....</b>	<b>3</b>
<b>Parts Reference.....</b>	<b>4-5</b>
<b>Setup Instructions .....</b>	<b>6-9</b>
<b>Operating Instructions .....</b>	<b>10</b>
<b>Operating Time Table.....</b>	<b>11</b>
<b>Maintenance.....</b>	<b>12-13</b>
<b>Pool Care and Chemicals.....</b>	<b>13</b>
<b>Long Term Storage.....</b>	<b>13</b>
<b>Troubleshooting Guide.....</b>	<b>14</b>
<b>Common Pool Problems.....</b>	<b>15</b>
<b>General Aquatic Safety.....</b>	<b>16</b>
<b>Limited Warranty.....</b>	<b>17</b>

## IMPORTANT SAFETY RULES

Read, Understand and Follow All Instructions Carefully Before Installing and Using this Product.

### READ AND FOLLOW ALL INSTRUCTIONS

#### WARNING

- To reduce the risk of injury, do not permit children to use this product. Always supervise children and those with disabilities.
- Children must stay away from this product and electrical cord(s).
- Assembly and disassembly by adults only.
- Risk of electric shock. Connect only to a grounding type receptacle, this product is provided with a ground-fault circuit interrupter. If replacement of the plug or cord is needed, use only identical replacement parts.
- Always unplug this product from the electrical outlet before removing, cleaning, servicing or making any adjustment to the product.
- The unit is provided with a ground-fault circuit interrupter (GFCI). To test the GFCI, push the test button. The GFCI should interrupt power. Push the reset button, power should be restored. If the GFCI fails to operate in this manner. The GFCI is defective. If the GFCI interrupts power to the pump without the test button being pushed, a ground current is flowing, indicating the possibility of an electric shock. Do not use this pump. Disconnect the pump and have the problem corrected by a qualified service representative before using.
- Do not bury the electrical cord. Locate the cord where it will not be damaged by lawn mowers, hedge trimmers and other equipment.
- To reduce the risk of electric shock, replace damaged cord immediately. Use a qualified electrician to replace the cord.
- To reduce the risk of electric shock, do not use extension cords, timers, plug adaptors or converter plugs to connect unit to electric supply; provide a properly located outlet.
- Do not attempt to plug in or unplug this product while standing in water or when your hands are wet.
- Do not use an appliance leakage current interrupter (ALCI) in place of a GFCI since the ALCI will not protect people.
- Position this product away from the pool, so as to prevent children from climbing on it and accessing the pool.
- **Do not operate this product when the pool is occupied.**
- This product is intended to be used only for the purposes described in the manual!

**FAILURE TO FOLLOW THESE WARNINGS MAY RESULT IN PROPERTY DAMAGE, ELECTRIC SHOCK, ENTANGLEMENT OR OTHER SERIOUS INJURY OR DEATH.**

#### CAUTION

**This product is for use with storable pools only. Do not use with permanently-installed pools. A storable pool is constructed so that it is capable of being readily disassembled for storage and reassembled to its original integrity. A permanently-installed pool is constructed in or on the ground or in a building such that it cannot be readily disassembled for storage.**

**To reduce the risk of electric shock the pool must be installed no closer than 6 feet (1.8 m) from any electrical outlet. Do not place portable appliances closer than 5 feet (1.5 m) from the pool.**

These product warnings, instructions and safety rules provided with the product represent some common risks of water recreation devices and do not cover all instances of risk and danger. Please use common sense and good judgement when enjoying any water activity.

## PARTS REFERENCE

Before assembling your product, please take a few minutes to check the contents and become familiar with all the parts.

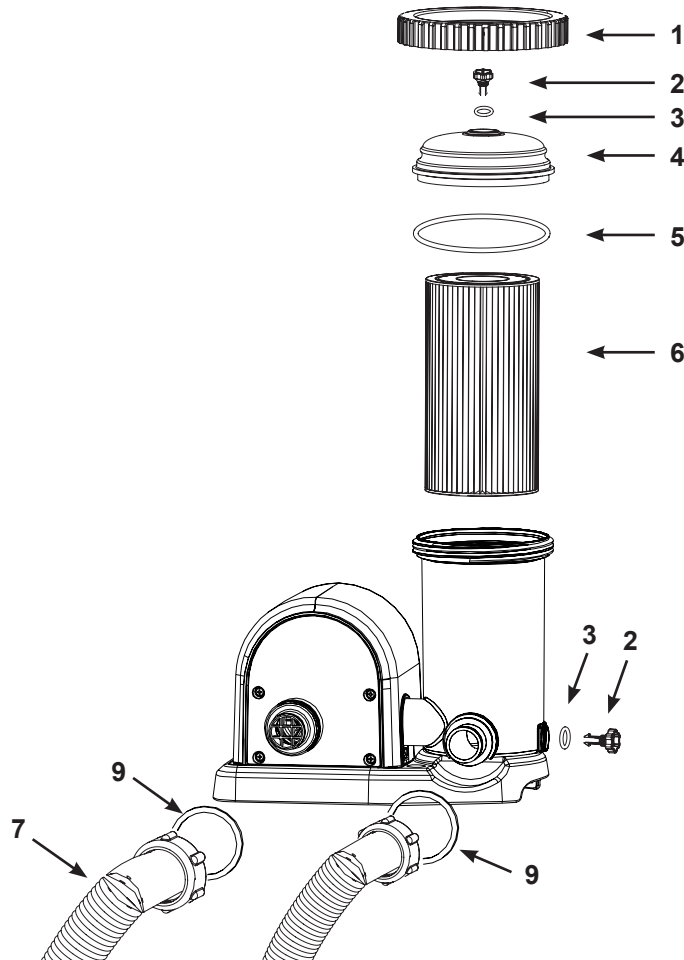

**NOTE:** Drawings for illustration purpose only. Actual product may vary. Not to scale.

REF. NO.	DESCRIPTION	QTY.	SPARE PART NO.
1	THREADED FILTER HOUSING COLLAR	1	10749
2	AIR RELEASE VALVE/SEDIMENT RELEASE VALVE	2	10460
3	VALVE O-RING	2	10264
4	FILTER HOUSING COVER	1	10750
5	FILTER HOUSING O-RING	1	10325
6	FILTER CARTRIDGE (29000)	1	
7	PUMP HOSE WITH NUTS	2	11009

When ordering parts, be sure to quote the model number and part numbers.  
No tools are required for the assembly.

## PARTS REFERENCE (continued)

Before assembling your product, please take a few minutes to check the contents and become familiar with all the parts.

Parts shown on this page are supplied with the pool package and are shown here for assembly purposes only.

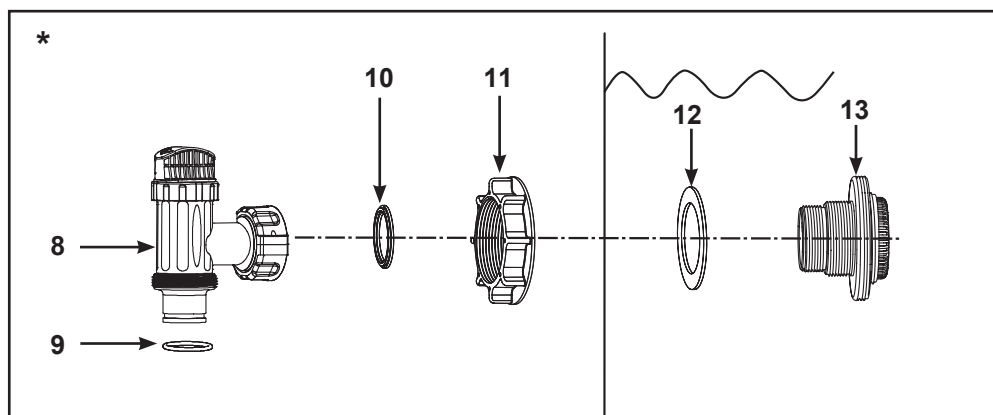
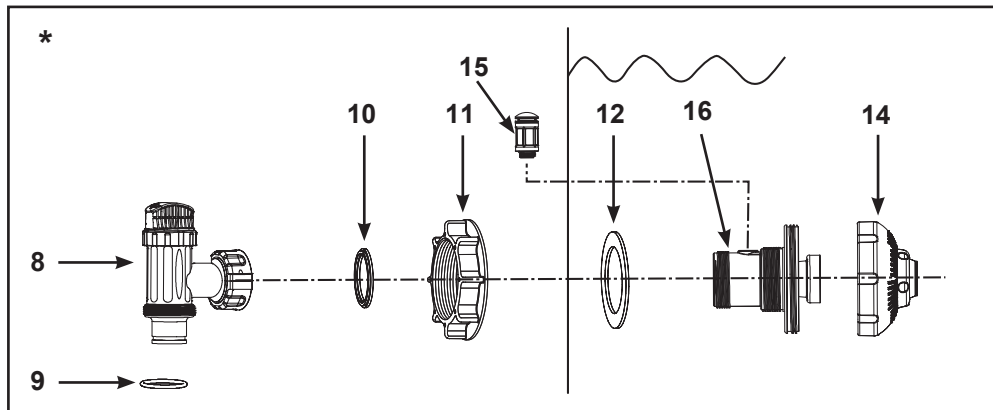

**NOTE:** Drawings for illustration purpose only. Actual product may vary. Not to scale.

REF. NO.	DESCRIPTION	QTY.	SPARE PART NO.
8*	PLUNGER VALVE (#9 & #10 INCLUDED)	2	10747
9*	HOSE O-RING	4	10262
10*	STEP WASHER		10745
11*	STRAINER NUT	2	10256
12*	FLAT STRAINER RUBBER WASHER	2	10255
13*	THREADED STRAINER CONNECTOR	1	11235
14*	ADJUSTABLE POOL INLET JET NOZZLE	1	12369
15*	AIR JET VALVE	1	12363
16*	INLET THREADED AIR CONNECTOR	1	12371
17*	AIR JET VALVE CAP (NOT SHOWN)	1	12373

\* If this pump was not purchased as part of a pool set, the above parts can be ordered at [www.intexcorp.com](http://www.intexcorp.com) if needed. When ordering parts, be sure to quote the model number and part numbers.

## POOL OUTLET - STRAINER & PLUNGER VALVE SETUP (optional)

The strainer grid prevents large objects from jamming and/or damaging the filter pump. The plunger valve assembly prevents water from flowing into the filter pump while the filter cartridge is being placed or cleaned. If your pool has inflatable top ring, install the strainer, nozzle and plunger valve before inflating the pool liner top ring. The parts numbers here onward, refer to the parts depicted in the Parts List section of this manual. To install, do the following:

1. In a counter-clockwise motion unscrew plunger valve union from the threaded strainer connector (13) (see drawing 1). Be careful not to lose the step rubber washer (10). Place the plunger valve on the ground in a safe place.
2. In a counter-clockwise motion unscrew the strainer nut (11) from the threaded connector (13). Leave the flat washer (12) on the connector (13).
3. Install the strainer and plunger valve at the lower position of pool outlet (marked "+"). From the inside of the pool liner insert the connector (13) into one of the pre-cut holes with the washer remaining on the connector to be placed against the inside of the liner wall.
4. Before assembly, lubricate the threads with a petroleum jelly. Then, with the flat side of the strainer nut (11) facing the outside wall of the liner in a clockwise motion screw the strainer nut (11) back onto the threaded connector (13) (see drawing 2).
5. Finger tighten the strainer nut (11) onto the threaded connector (13).
6. Grasp the plunger valve assembly. Make sure the step washer (10) is in place.
7. In a clockwise motion screw the plunger valve union back onto the threaded connector (13) (see drawing 3).
8. In a clockwise motion turn the plunger valve handle to close position. Ensure the plunger valve is securely closed. This will prevent water from flowing out during filling of the pool (see drawings 4).

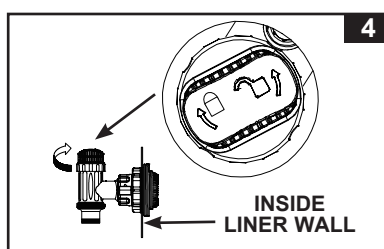
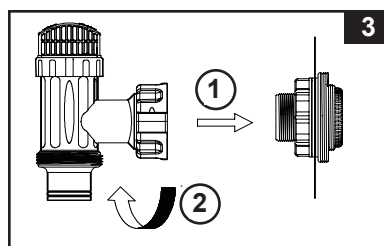
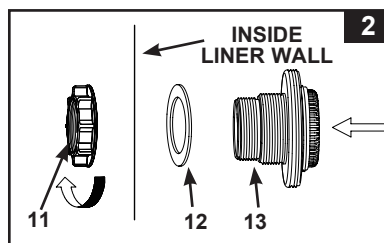
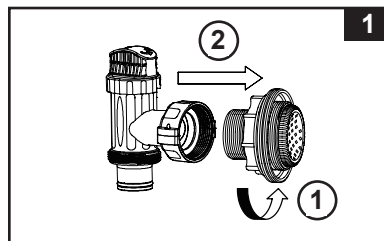

## POOL INLET - NOZZLE & PLUNGER VALVE SETUP (optional)

1. In a counter-clockwise motion unscrew plunger valve union from the inlet threaded air connector (16) (see **drawing 5**) Be careful not to lose the step rubber washer (10). Place the plunger valve on the ground in a safe place.
2. In a counter-clockwise motion unscrew the strainer nut (11) from the inlet threaded air connector (16). Leave the flat washer (12) on the connector (16).
3. Install the nozzle and plunger valve at the upper position of pool inlet. From the inside of the pool liner insert the nozzle union (14 & 16) into one of the pre-cut holes with the washer remaining on the connector to be placed against the inside of the liner wall.
4. Before assembly, lubricate the threads with a petroleum jelly. Then, with the flat side of the strainer nut (11) facing the outside wall of the liner in a clockwise motion screw the strainer nut (11) back onto the inlet threaded air connector (16) (see **drawing 6**).
5. Finger tighten the adjustable pool inlet jet nozzle (14) and the strainer nut (11) onto the inlet threaded air connector (16).
6. Grasp the plunger valve assembly. Make sure the step washer (10) is in place.
7. Screw the air jet valve (15) over the inlet threaded air connector (16). **NOTE:** Make sure the air jet valve is securely tighten and facing up. In a clockwise motion screw the plunger valve union back onto the inlet threaded air connector (16) (see **drawing 7**).
8. In a clockwise motion turn the plunger valve handle to close position. Ensure the plunger valve is securely closed. This will prevent water from flowing out during filling of the pool (see **drawing 8**).
9. Adjust the direction of the nozzle head pointing away from the pool outlet for a better circulation result (see **drawing 9**).
10. The pool liner is now ready to be filled with water. Consult the above-ground-pool owner's manual for the filling instructions.

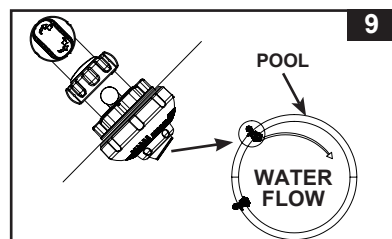
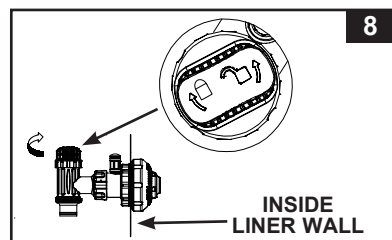
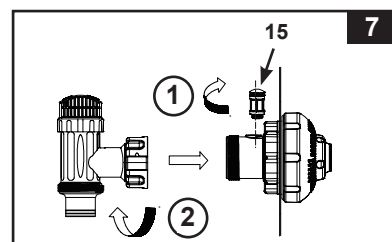
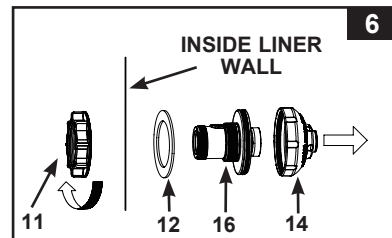
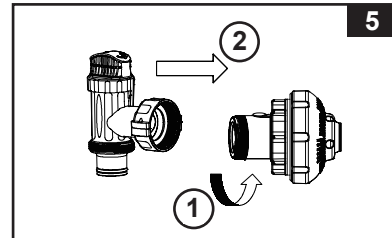

## FILTER PUMP HOSE CONNECTION SETUP

1. Remove the Krystal Clear™ filter pump and hoses from the packaging.
2. Place the filter pump in such a manner, that you can easily assemble the hose (7) connections to the plunger valve.
 

**Note: Some regional regulations may require the filter pump to be mounted on a stationary platform. There are two mounting holes located in the pump base for this reason. Consult your local authorities for filter-pump mounting requirements.**
3. Grasp the two pump hoses (7) and connect the hose nuts to the filter pump.
4. In a counter-clockwise motion unscrew the threaded filter housing collar (1) from the filter housing. Place it in a safe place.
5. The filter pump is an airtight system. Turn the top air release valve (2) once or twice in a counter-clockwise motion.
 

**DO NOT remove the air release valve from the top cover, as water will expel with force if the motor is turned on. This may cause injury.**
6. Grasp and remove the filter housing cover (4). Check to see if a cartridge is inside the housing. If yes, replace the cover, finger tighten the housing collar (1) back onto the filter housing.
7. Gently finger tighten the sediment release valve located at the bottom of the housing to be sure that water does not leak out.
8. When the pool is filled connect the hose from the bottom of the filter housing to the highest strainer assembly. You will find the hose connection at the bottom of the plunger valve assembly. Use the hose nut to attach the hose.
9. Connect the second hose which is fixed to the middle of the motor housing to the remaining liner connection.

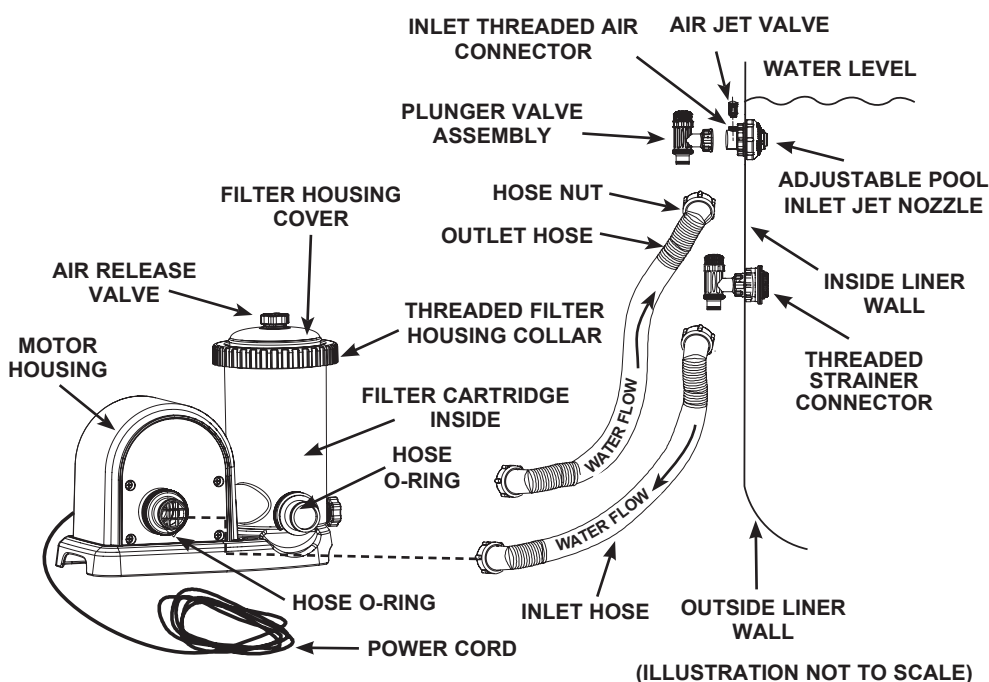



## FILTER PUMP HOSE CONNECTION SETUP (continued)

### For Pools with Dual Suction Outlets Configuration:

In order to comply with the requirement of the Virginia Graeme Baker Act (for USA and Canada), your pool is designed with dual suction outlets and one inlet fittings. Parts in grey highlight on this page are supplied with the pool set package and are shown here for assembly purposes only. If this pump was purchased as part of a pool set, refer to the pool owner's manual for more details.

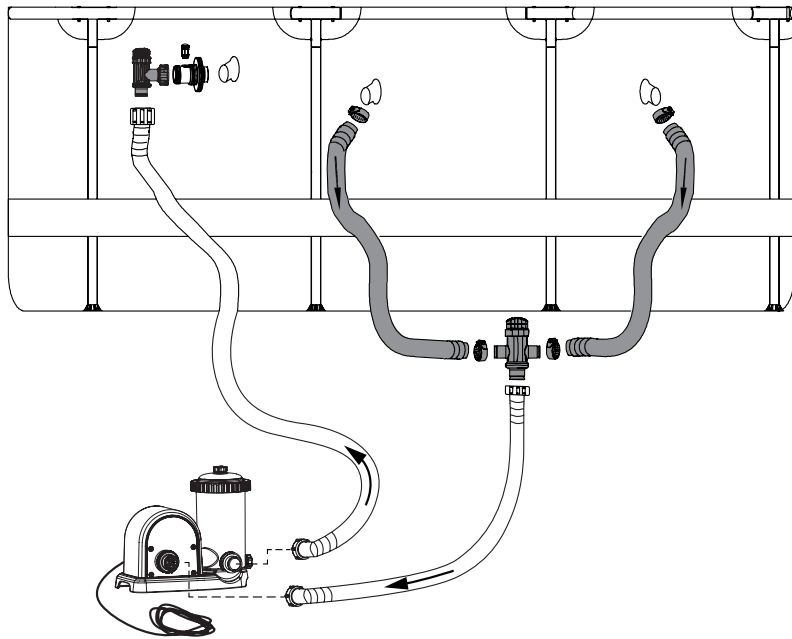

(ILLUSTRATION NOT TO SCALE)

### **WARNING**

Position this product away from the pool, so as to prevent children from climbing on it and accessing the pool.

## OPERATING INSTRUCTIONS

1. Make sure the filter pump is switched off. The switch is located on the motor housing.
2. Connect the power cord to a GFCI protected electrical outlet.

### **⚠ WARNING**

**Risk of electric shock. Connect this product only to a grounding type receptacle protected by a ground-fault circuit interrupter (GFCI). Contact a qualified electrician if you cannot verify that the receptacle is protected by a GFCI.**

### **IMPORTANT**

**To prevent air lock, open the lower plunger valve (connected inlet hose) first and then the upper plunger valve (connected outlet hose). Open the air release valve, wait until water starts to flow out of the air release valve, close air release valve.**

3. Turn both plunger valve handles fully counter-clockwise until they stop. This opens the valve, allowing water to flow into the filter pump.
  4. With water flowing into filter pump, the water pressure will allow the air trapped inside to escape from the air release valve (2). When all the air has escaped water will flow out of the valve (2). When this occurs gently finger tighten the valve (2) in a clockwise direction.
  5. **To operate the filter pump on "TIMER" mode:**
    - A. Set the timer dial to the desired operating hours. See operation time table. See Fig. 10
    - B. Turn on the pump by pressing the switch to "⊕" position, the filter pump is now filtering the water and will stop after the operating hours are completed. The built-in timer will now operate for the number of hours selected at the same time each day.
    - C. Operating hours can be re-adjusted if necessary. Follow step A – B.
- To operate the filter pump manually (without the "TIMER" mode):**
- A. Turn on the pump by pressing the switch to "-" position, the filter pump is now filtering the water.
  - B. To turn off the pump, press the switch to "O" position.

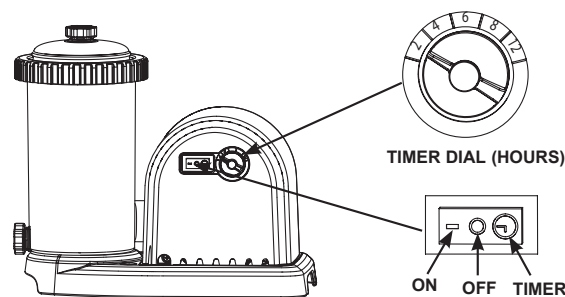

FIG 10

6. Never put pool chemicals directly into the filter pump. This may damage the pump and void the warranty.

## OPERATING TIME TABLE

This table shows the required operating time for average use of the filter pump with AGP's. The filter pump running time should be 1 hour longer than the required operating time of the Saltwater System.

Pool Size	Water Capacity (Calculated at 90% for Frame Pool and 80% for Easy Set & Oval Pool)		Recommend operating hours per day	
	(Gals)	(Liters)	(Hours)	
<b>INTEX ABOVE GROUND POOLS (AGP's)</b>				
<b>EASY SET® POOL</b>	18' x 42" (549cm x 107cm)	4,786	18,115	4
	18' x 48" (549cm x 122cm)	5,455	20,647	6
<b>CIRCULAR METAL FRAME POOL</b>	18' x 48" (549cm x 122cm)	6,423	24,311	6
	21' x 52"	9,533	36,082	8
<b>ULTRA FRAME POOL</b>	16' x 48" (488cm x 122cm)	5,061	19,156	4
	18' x 48" (549cm x 122cm)	6,423	24,311	6
	18' x 52" (549cm x 132cm)	6,981	26,423	6
	20' x 48"	7,947	30,079	6
<b>GRAPHITE GRAY PANEL POOL SET™</b>	15'8" x 49"	4,440	16,805	4
	16'8" x 49" (508cm x 124cm)	5,061	19,156	4
	18'8" x 53" (569cm x 135cm)	6,981	26,423	6
<b>OVAL FRAME POOL</b>	20' x 12' x 48" (610cm x 366cm x 122cm)	4,393	16,628	4
<b>RECT. ULTRA FRAME POOL</b>	15' x 9' x 48"	3,484	13,187	4
	18' x 9' x 52" (549cm x 274cm x 132cm)	4,545	17,203	4
	20' x 10' x 52"	5,611	21,238	4
	24' x 12' x 52" (732cm x 366cm x 132cm)	8,403	31,805	6

## CLEANING OR REPLACING FILTER CARTRIDGES

**It is recommended that the filter cartridge be replaced at least every 2 weeks.**

1. Make sure the filter pump is turned off, then disconnect the power cord from the electrical outlet.
2. Turn both plunger valve handles fully clockwise until they stop. This closes the valve, prevents the water from flowing out of the pool.
3. Gently turn the top air release valve once or twice in a counter-clockwise direction. The housing cover can now be easily removed.
4. In a counter-clockwise direction remove the filter housing collar **(1)**. Place it in a safe location.
5. Remove the housing cover **(4)**.
6. Now remove the used filter cartridge.
7. Examine the inside of the filter housing.
8. If dirt or sediment is located on the bottom of the housing then:
  - A. In a counter-clockwise motion gently unscrew and remove the sediment valve **(2)** located at the bottom of the housing. Place it in a safe place.
  - B. With a bucket of water or a garden hose pour water into the housing flushing out the sediment.
  - C. Screw back the sediment valve **(2)** in a gentle clockwise motion. Do not over-tighten.
9. Place a new cartridge filter in the housing.
10. Return the housing cover **(4)** to its position and in a clockwise direction rescrew the housing collar **(1)** onto the filter housing.
11. Turn both plunger valve handles fully counter-clockwise until they stop. This opens the valve, allowing water to flow into the filter pump.
12. When the trapped air has escaped through the air release valve gently retighten the valve **(2)** in a clockwise direction.
13. Reconnect the power cord.
14. Turn on the pump.

## POOL CARE & CHEMICALS

- All pools require care to keep the water clear and hygienically clean. With proper chemical control, your filter will help attain this objective. Consult your pool supply dealer for instructions regarding the proper use of chlorine, algaecide and other chemical agents required for sparkling clear water.
- Keep pool chemicals away from children.
- Do not replenish chemicals in pool while pool is occupied. Skin or eye irritations could occur.
- Daily pH checking and chemical treatment of the water is very important and cannot be overemphasized. Chlorine, algaecide and maintenance of proper pH levels are required when filling the pool as well as during the season. Consult your local swimming pool supply store for instructions.
- The season's first filling of the pool may have brackish water requiring extra water additives and extra filter changes. Do not allow swimming in pool until the pH level is balanced. Consult your local swimming pool supply store for instructions.
- Keep spare filter cartridges on hand. Replace cartridges every two weeks.
- Chlorinated water may damage lawns, gardens or shrubbery as children play in the pool and splash water outside the pool. Lawn areas underneath the pool liner will be destroyed. Note that some types of grass may grow through the liner.
- Filter run time depends on pool size, weather and usage level. Experiment with various run times so as to produce clean clear water.

### CAUTION

**Concentrated chlorine solutions may damage the pool liner. Always follow the chemical manufacturer's directions, and the health and hazard warnings.**

## LONG TERM STORAGE

1. Before emptying your pool for long term storage, or relocation, be sure the water is directed towards an acceptable drain water receptacle away from the house. Check local regulations for specific directions regarding disposal of swimming pool water.
2. Disconnect power cord from electrical outlet.
3. Now, drain the pool.
4. When the pool is empty, disconnect all hoses from pump and plunger valves and remove the strainers from the pool wall.
5. Drain all water from the filter pump.
6. Leave filter pump pieces & hoses outside to thoroughly air dry.
7. Remove both plunger valves from the connectors (**13 & 16**). Be careful not to lose the step rubber washer (**10**).
8. Coat the following O-rings and washers with petroleum jelly for long term storage:
  - Air release valve & sediment O-rings (**3**).
  - Filter housing cover O-ring (**5**).
  - Pump hose O-rings (**9**).
  - Strainer valve assembly step washers (**10**).
  - Flat strainer rubber washers (**12**).
9. Discard the used filter cartridge. Put aside 1 or 2 new cartridges for next season's use.
10. It is best to place all dry pieces in the original packaging for storage or place them in an airtight plastic bag.
11. Store the unit and accessories in a dry place. The storage's temperature should be controlled, between 32 degrees Fahrenheit (0 degrees Celsius) and 104 degrees Fahrenheit (40 degrees Celsius) storage location.

### IMPORTANT

**It is best to store away your poolsystem in its original packaging.**

## TROUBLESHOOTING GUIDE

TROUBLE	CAUSE	SOLUTION
FILTER MOTOR FAILS TO START	<ul style="list-style-type: none"> <li>• The motor is not plugged in.</li> <li>• The GFCI circuit breaker is tripped.</li> <li>• Motor too hot and overload protection shut motor off.</li> </ul>	<ul style="list-style-type: none"> <li>• Filter cord must be plugged into a 3 wire outlet that is protected by a Class A Ground Fault Circuit Interrupter.</li> <li>• Reset circuit breaker. If circuit breaker trips repeatedly, your electrical system may have a defect. Turn off circuit breaker and call an electrician to correct the problem.</li> <li>• Let motor cool down.</li> </ul>
FILTER DOESN'T CLEAN POOL	<ul style="list-style-type: none"> <li>• Improper chlorine or pH levels.</li> <li>• Filter cartridge is dirty.</li> <li>• Damaged cartridge.</li> <li>• Excessively dirty pool.</li> <li>• The strainer screen is restricting the water flow.</li> </ul>	<ul style="list-style-type: none"> <li>• Adjust the chlorine and pH level. Consult your local swimming pool supply stores.</li> <li>• Clean or replace cartridge.</li> <li>• Check the cartridge for holes. Replace if damaged.</li> <li>• Operate the filter for longer periods.</li> <li>• Clean the strainer screen at the inlet.</li> </ul>
FILTER DOESN'T PUMP WATER OR THE WATER FLOW IS VERY SLOW	<ul style="list-style-type: none"> <li>• Clogged inlet or discharge.</li> <li>• An air leak on the intake line.</li> <li>• Scale or buildup on cartridge.</li> <li>• Excessively dirty pool.</li> <li>• Dirty filter cartridge.</li> <li>• The nozzle and strainer connection are reversed.</li> <li>• Inlet threaded air connector connected to the wrong hole on the liner.</li> </ul>	<ul style="list-style-type: none"> <li>• Clear any obstructions in the intake hose by discharging it inside pool wall.</li> <li>• Tighten hose nuts, check hoses for damage, check pool water level.</li> <li>• Clean cartridge more often.</li> <li>• Clean inside the plunger valve.</li> <li>• Pull valve handle to full upright position.</li> <li>• Install the nozzle at the upper position of the pool inlet, and the strainer at the lower position of the pool outlet.</li> <li>• Make sure the inlet threaded air connector is connected to the pool inlet upper hole.</li> </ul>
PUMP DOESN'T WORK	<ul style="list-style-type: none"> <li>• Low water level.</li> <li>• Strainer screen plugged up.</li> <li>• An air leak on the intake hose.</li> <li>• Faulty motor or the impeller is jammed.</li> <li>• An air lock inside the cartridge chamber.</li> </ul>	<ul style="list-style-type: none"> <li>• Fill pool to correct water level.</li> <li>• Clean strainer screens at pool inlet.</li> <li>• Tighten hose nuts, check hose for damage.</li> <li>• Clear any sticks or leaves in the intake hose.</li> <li>• Turn and pull valve handle to full upright position.</li> </ul>
TOP COVER LEAKING	<ul style="list-style-type: none"> <li>• O-ring missing.</li> <li>• Cover or air release valve are not tight.</li> </ul>	<ul style="list-style-type: none"> <li>• Remove cover &amp; check for O-ring.</li> <li>• Tighten cover or valve (Manually).</li> </ul>
HOSE LEAKING	<ul style="list-style-type: none"> <li>• Hose nuts are not well-fitted.</li> <li>• Hose o-ring dislodged when connecting the hose.</li> <li>• Hose broken.</li> </ul>	<ul style="list-style-type: none"> <li>• Tighten or reinstall hose nut.</li> <li>• Put the o-ring back into the groove.</li> <li>• Replace a new hose.</li> </ul>
AIR LOCK	<ul style="list-style-type: none"> <li>• There's air trapped in the pump housing and inlet hose.</li> <li>• The inlet and outlet hoses connection are reversed.</li> </ul>	<ul style="list-style-type: none"> <li>• Open air release valve, wait until water starts to flow out of the air release valve, close air release valve.</li> <li>• The lower position of pool outlet connects to filter pump water inlet. The upper position of pool inlet connects to filter pump water outlet.</li> </ul>
INLET TREADED AIR CONNECTOR / AIR JET VALVE LEAKING	<ul style="list-style-type: none"> <li>• Plunger valve not well-fitted.</li> <li>• Air jet valve is not tight and facing up.</li> <li>• Air jet valve internal seal blocked.</li> <li>• Air jet valve internal seal dirty.</li> <li>• Air jet valve broken.</li> </ul>	<ul style="list-style-type: none"> <li>• Tighten or reinstall plunger valve.</li> <li>• Tighten air jet valve and make sure it's facing up.</li> <li>• Turn pump ON and run for few seconds, then turn OFF, repeat 3 times.</li> <li>• Remove air jet valve, flush dirt out with water and replace valve back.</li> <li>• Replace a new air jet valve.</li> </ul>

## COMMON POOL PROBLEMS

TROUBLE	DESCRIPTION	CAUSE	SOLUTION
ALGAE	<ul style="list-style-type: none"> <li>• Greenish water.</li> <li>• Green or black spots on pool liner.</li> <li>• Pool liner is slippery and/or has a bad odor.</li> </ul>	<ul style="list-style-type: none"> <li>• Chlorine and pH levels need adjustment.</li> </ul>	<ul style="list-style-type: none"> <li>• Super chlorinate with shock treatment. Correct pH to your pool store's recommended level.</li> <li>• Vacuum pool bottom.</li> <li>• Maintain proper chlorine level.</li> </ul>
COLORED WATER	<ul style="list-style-type: none"> <li>• Water turns blue, brown, or black when first treated with chlorine.</li> </ul>	<ul style="list-style-type: none"> <li>• Copper, iron or manganese in water being oxidized by the added chlorine. This is common.</li> </ul>	<ul style="list-style-type: none"> <li>• Adjust pH level to the recommended level.</li> <li>• Run filter until water is clear.</li> <li>• Clean cartridge frequently.</li> </ul>
FLOATING MATTER IN WATER	<ul style="list-style-type: none"> <li>• Water is cloudy or milky.</li> </ul>	<ul style="list-style-type: none"> <li>• "Hard water" caused by a too high pH level.</li> <li>• Chlorine content is low.</li> <li>• Foreign matter in water.</li> </ul>	<ul style="list-style-type: none"> <li>• Correct the pH level. Check with your pool dealer for advice.</li> <li>• Adjust the chlorine level.</li> <li>• Clean or replace your filter.</li> </ul>
CHRONIC LOW WATER LEVEL	<ul style="list-style-type: none"> <li>• Level is lower than on previous day.</li> </ul>	<ul style="list-style-type: none"> <li>• Rip or hole in pool liner or hoses.</li> <li>• The drain valves are loose.</li> </ul>	<ul style="list-style-type: none"> <li>• Repair with a patch kit.</li> <li>• Finger tighten all caps.</li> </ul>
SEDIMENT ON POOL BOTTOM	<ul style="list-style-type: none"> <li>• Dirt or sand on pool floor.</li> </ul>	<ul style="list-style-type: none"> <li>• Heavy use, getting in and out of pool.</li> </ul>	<ul style="list-style-type: none"> <li>• Use Intex pool vacuum to clean bottom of pool.</li> </ul>
SURFACE DEBRIS	<ul style="list-style-type: none"> <li>• Leaves, insects etc.</li> </ul>	<ul style="list-style-type: none"> <li>• Pool too close to trees.</li> </ul>	<ul style="list-style-type: none"> <li>• Use Intex pool skimmer.</li> </ul>

## IMPORTANT

**If you continue to experience difficulty, please contact our Consumer Service Department for assistance. See separate "Authorized Service Centers" sheet.**

Operation is subject to the following two conditions: (1) this device may not cause interference, and (2) this device must accept any interference, including interference that may cause undesired operation of the device. Changes or modifications not expressly approved by the party responsible for compliance could void the user's authority to operate the equipment.

This equipment has been tested and found to comply with the limits for Class B digital device, pursuant to part 15 of the FCC Rules. These limits are designed to provide reasonable protection against harmful interference in a residential installation. This equipment generates, uses and can radiate radio frequency energy and, if not installed and used in accordance with the instructions, may cause harmful interference to radio communications. However, there is no guarantee that interference will not occur in a particular installation. If this equipment does cause harmful interference to radio or television reception, which can be determined by turning the equipment off and on, the user is encouraged to try to correct the interference by one or more of the following measures:

- Reorient or relocate the receiving antenna.
- Increase the separation between the equipment and the receiver.
- Connect the equipment into an outlet on a circuit different from that to which the receiver is connected.
- Consult the dealer or an experienced radio/TV technician for help.

## GENERAL AQUATIC SAFETY

Water recreation is both fun and therapeutic. However, it involves inherent risks of injury and death. To reduce your risk of injury, read and follow all product, package and package insert warnings and instructions. Remember, however, that product warnings, instructions and safety guidelines cover some common risks of water recreation, but do not cover all risks and dangers.

For additional safeguards, also familiarize yourself with the following general guidelines as well as guidelines provided by nationally recognized Safety Organizations:

- Demand constant supervision. A competent adult should be appointed as a "lifeguard" or water watcher, especially when children are in and around the pool.
- Learn to swim.
- Take the time to learn CPR and first aid.
- Instruct anyone who is supervising pool users about potential pool hazards and about the use of protective devices such as locked doors, barriers, etc.
- Instruct all pool users, including children what to do in case of an emergency.
- Always use common sense and good judgement when enjoying any water activity.
- Supervise, supervise, supervise.

For additional information on safety, please visit

- **The Association of Pool and Spa Professionals: The Sensible Way to Enjoy Your Aboveground/Onground Swimming Pool** [www.nspi.org](http://www.nspi.org)
- **American Academy of Pediatrics: Pool Safety for Children** [www.aap.org](http://www.aap.org)
- **Red Cross** [www.redcross.org](http://www.redcross.org)
- **Safe Kids** [www.safekids.org](http://www.safekids.org)
- **Home Safety Council: Safety Guide** [www.homesafetycouncil.org](http://www.homesafetycouncil.org)
- **Toy Industry Association: Toy Safety** [www.toy-tia.org](http://www.toy-tia.org)



## LIMITED WARRANTY

Your Krystal Clear™ Filter-Pump has been manufactured using the highest quality materials and workmanship. All Intex products have been inspected and found free of defects prior to leaving the factory. This Limited Warranty applies only to the Krystal Clear™ Filter-Pump and accessories listed below.

The provisions of this Limited Warranty apply only to the original purchaser and is not transferable. This Limited Warranty is valid for the period noted below from the date of the initial retail purchase. Keep your original sales receipt with this manual, as proof of purchase will be required and must accompany warranty claims or the Limited Warranty is invalid.

Krystal Clear™ Filter-Pump Warranty – 1 Year

Hoses, Plunger Valves & Fittings Warranty – 180 days

If a manufacturing defect is found within the periods noted above, please contact the appropriate Intex Service Center listed in the separate "Authorized Service Centers" sheet. The Service Center will determine the validity of the claim. If the Service Center directs you to return the product, please carefully package the product and send with shipping and insurance prepaid to the Service Center. Upon receipt of the returned product, the Intex Service Center will inspect the item and determine the validity of the claim. If the provisions of this warranty cover the item, the item will be repaired or replaced at no charge.

Any and all disputes regarding the provisions of this Limited Warranty shall be brought before an informal dispute settlement board and unless and until the provisions of these paragraphs are carried forth, no civil action may be instituted. The methods and procedures of this settlement board shall be subject to the rules and regulations set forth by the Federal Trade Commission (F.T.C.). IMPLIED WARRANTIES ARE LIMITED TO THE TERMS OF THIS WARRANTY AND IN NO EVENT SHALL INTEX, THEIR AUTHORIZED AGENTS OR EMPLOYEES BE LIABLE TO THE BUYER OR ANY OTHER PARTY FOR DIRECT OR CONSEQUENTIAL DAMAGES OR LIABILITIES. Some states, or jurisdictions do not allow the exclusion or limitation of incidental or consequential damages, so the above limitation or exclusion may not apply to you.

This Limited Warranty does not apply if the products are subject to negligence, abnormal use or operation, accident, improper operation, improper voltage or current contrary to operating instructions, or to damage by circumstances beyond Intex's control, including but not limited to, ordinary wear and tear and damage caused by exposure to fire, flood, freezing, rain, or other external environmental forces. This Limited Warranty applies only to those parts and components sold by Intex. The Limited Warranty does not cover unauthorized alterations, repairs or disassembly by anyone other than Intex Service Center personnel.

**DO NOT GO BACK TO THE PLACE OF PURCHASE FOR RETURN OR REPLACEMENT. IF YOU ARE MISSING PARTS OR NEED ASSISTANCE, PLEASE CALL US TOLL-FREE (FOR U.S. AND CANADIAN RESIDENTS): 1-800-234-6839 OR VISIT OUR WEBSITE: WWW.INTEXSTORE.COM.**

Proof of Purchase must accompany all returns or the warranty claim will be invalid.