

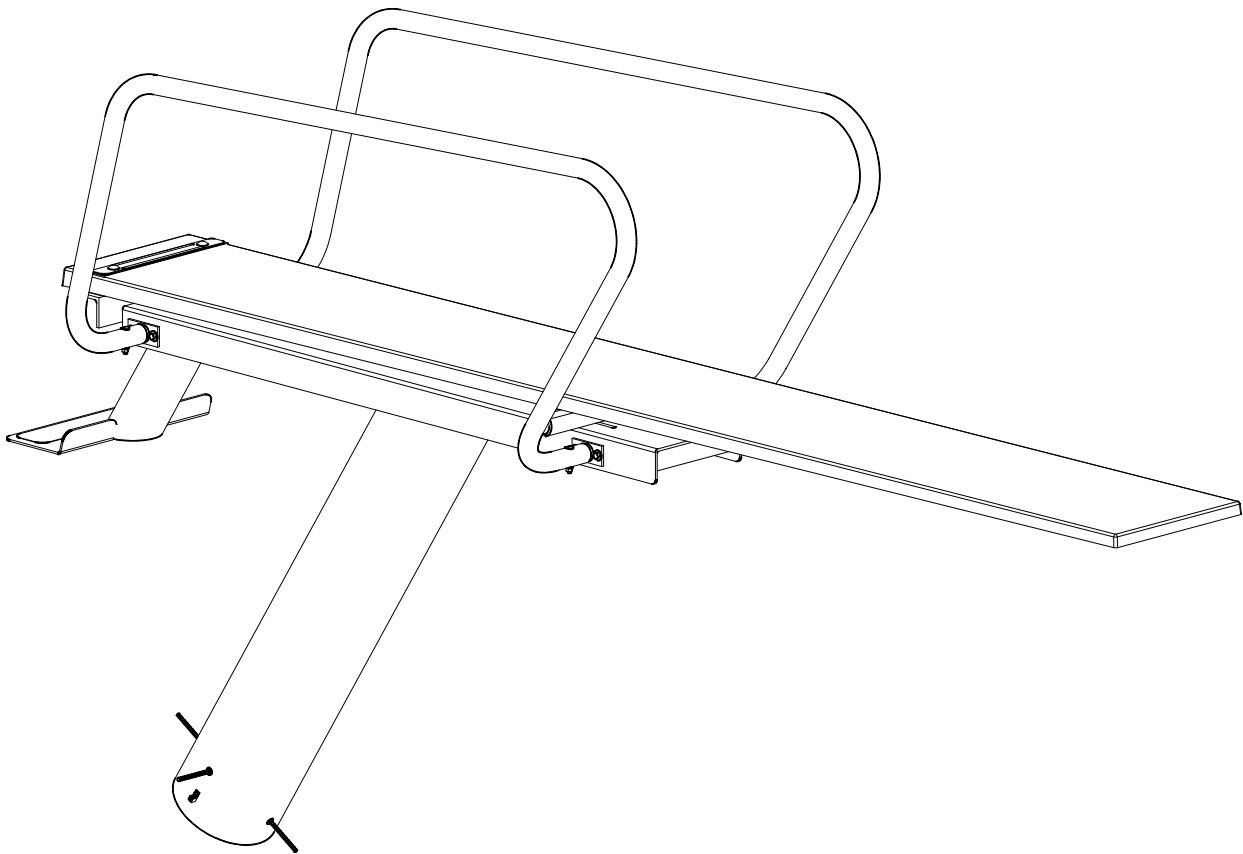

1 METER ECONOLINE DIVING STANDS

ASSEMBLY AND INSTALLATION INSTRUCTIONS



**CORPORATE HEADQUARTERS
WESTERN SALES AND MANUFACTURING PLANT
P.O. Box 400 • 1017 SW Berg Parkway
Canby, Oregon 97013
(503) 266-2231 • Fax (503) 266-4334
www.srsmith.com**

INTRODUCTION

The 1 METER DECK LEVEL DIVING STAND is designed for use on competitive or municipal pools. It provides a safe, unique look with a minimal amount of deck space. Proper and complete assembly, use, and maintenance are essential for proper operation and to reduce the risk of accident or injury.

****IMPORTANT****

Check entire box and inside all packing materials for parts. Before beginning assembly, read the instructions and identify parts using the figures and parts listed in this document. It is critical that all parts be carefully inspected by the installer prior to installation to ensure that no damage occurred in transit and that a damaged part is not used. Proper installation cannot be overstressed, as an improper installation voids S.R. Smith's warranty and may affect the safety of the user.

CRITICAL INSTALLATION DIMENSIONS

MODEL NO.	BOARD	FULCRUM	"A"	"H"
E-CAT-1M-100	12'	62"	65 1/4"	H = 34" – WATER LEVEL
E-CAT-1M-101	14'	74"	83 1/4"	H = 34" – WATER LEVEL

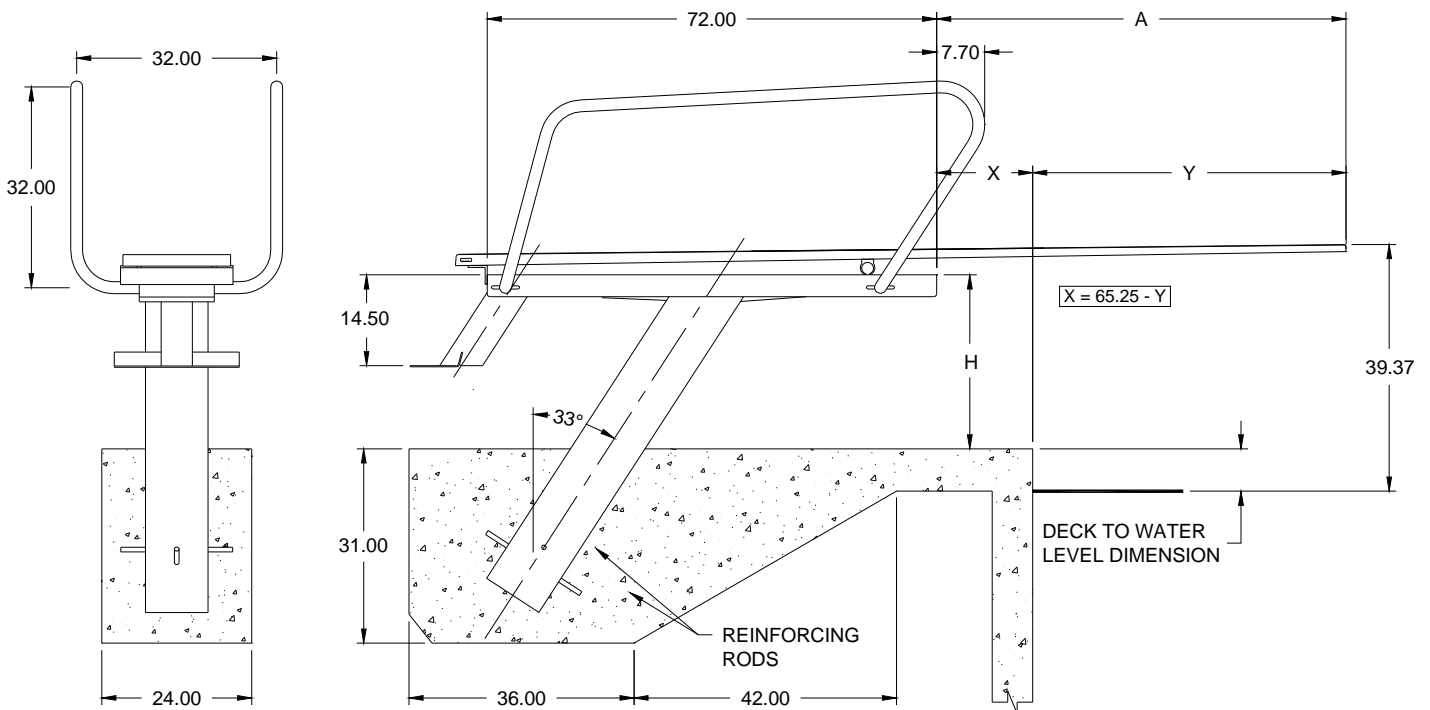

E-CAT-1M-100

FIG. 1

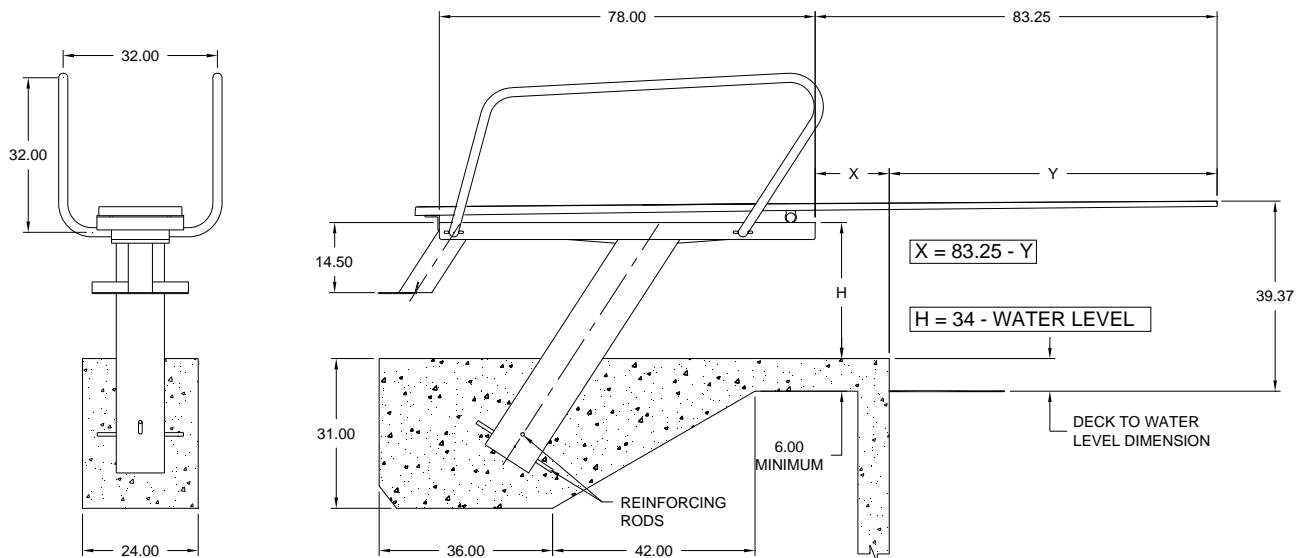

E-CAT-1M-101

FIG. 2

1 METER – ECONOLINE-100 & ECONOLINE-101 PARTS LIST

ITEM NO.	QTY.	PART NO.	DESCRIPTION
1	1	E-CAT-1M-100A	E-CAT-1M-100 STAND, LESS HARDWARE
1	1	E-CAT-1M-101A	E-CAT-1M-101 STAND, LESS HARDWARE
2	1	6-621	PLASTIC NON-SKID, ADHESIVE BACKED
3	1	25-101	FULCRUM ASSY
4	2	8-606	END CAP, PLASTIC
5	1	FC-100A	FULCRUM COVER, 20"
6	10	5-145	3/8" FLAT WASHER, S.S.
7	10	5-151	3/8" LOCK WASHER, S.S.
8	10	5-139	3/8" UNC, HEX NUT, S.S.
9	2	08-501	RUBBER MOUNTING PAD, 18"
10	4	25-102	BRACKET ASSY, HANDRAIL
11	8	05-32-133	3/8"-16 HEX BOLT, S.S.
12	1	25-104	ECAT 100 HANDRAILS
12	1	25-106	ECAT 101 HANDRAILS
13	4	5-170	3/8"-16 X 2-1/2" CRADLE HEAD BOLT
14	4	5-151	3/8" LOCK WASHER, SPLIT, SS
15	4	5-139	3/8" UNC, HEX NUT, SS
16	1	01-820	TOP MOUNT PLATE, 18" BOARD
17	2	05-31-171	1/2" X 3-1/2" CARRIAGE BOLT
18	2	05-14-115	1/2" LOCK WASHER, SPLIT C/S ZINC PLATED
19	2	05-33-116	1/2" HEX NUT C/S ZINC PLATED
20	2	05-618	NUT CAP, 1/2", WHITE PLASTIC
21	1		DIVING BOARD (ORDERED SEPERATELY)

ASSEMBLY INSTRUCTIONS

1. Refer to **Chart 1 RULE SHEET** for correct placement of the **E-CAT DIVING STAND**, which is **dependent on the type of pool and the length of diving board that is used**. Begin by setting the **E-CAT STAND (item 1)** in concrete per local building codes. Excavate area required for concrete base. See **FIGURE 1** for minimum dimensions of concrete surrounding the stand.
2. Ground the stand using provided grounding anchor, located on lower stand tube, per local electrical building codes.
3. Check stand for height and check for level in two directions, pour concrete. (Reinforcing rods (rebar) are customer supplied, use #3 X 16" long minimum) **FILL PIPE WITH CONCRETE THROUGH HOLE IN TRAY**.
4. Paint the diving stand using a high quality acrylic urethane enamel for a durable finish. Do not begin assembly of the **E-CAT STAND** until mounting concrete is fully cured.
5. Place **Plastic End Caps (item 4)** over the ends of **Fulcrum Assembly (item 3)**. Slide **Fulcrum Cover (item 5)** over fulcrum assembly. Place fulcrum assembly threaded studs through appropriate slots in **E-CAT Stand (item 1)**. To ensure proper fulcrum positioning see **TABLE 1**. Place **3/8" Flat Washer (item 6)** over the fulcrum assembly threaded studs. Place **3/8" Lock Washer (item 7)** over the fulcrum assembly threaded studs. Place **3/8" Hex Nut (item 8)** over the fulcrum assembly threaded studs. After appropriate fulcrum position has been determined and set, tighten hex nuts. See **FIG. 3**.

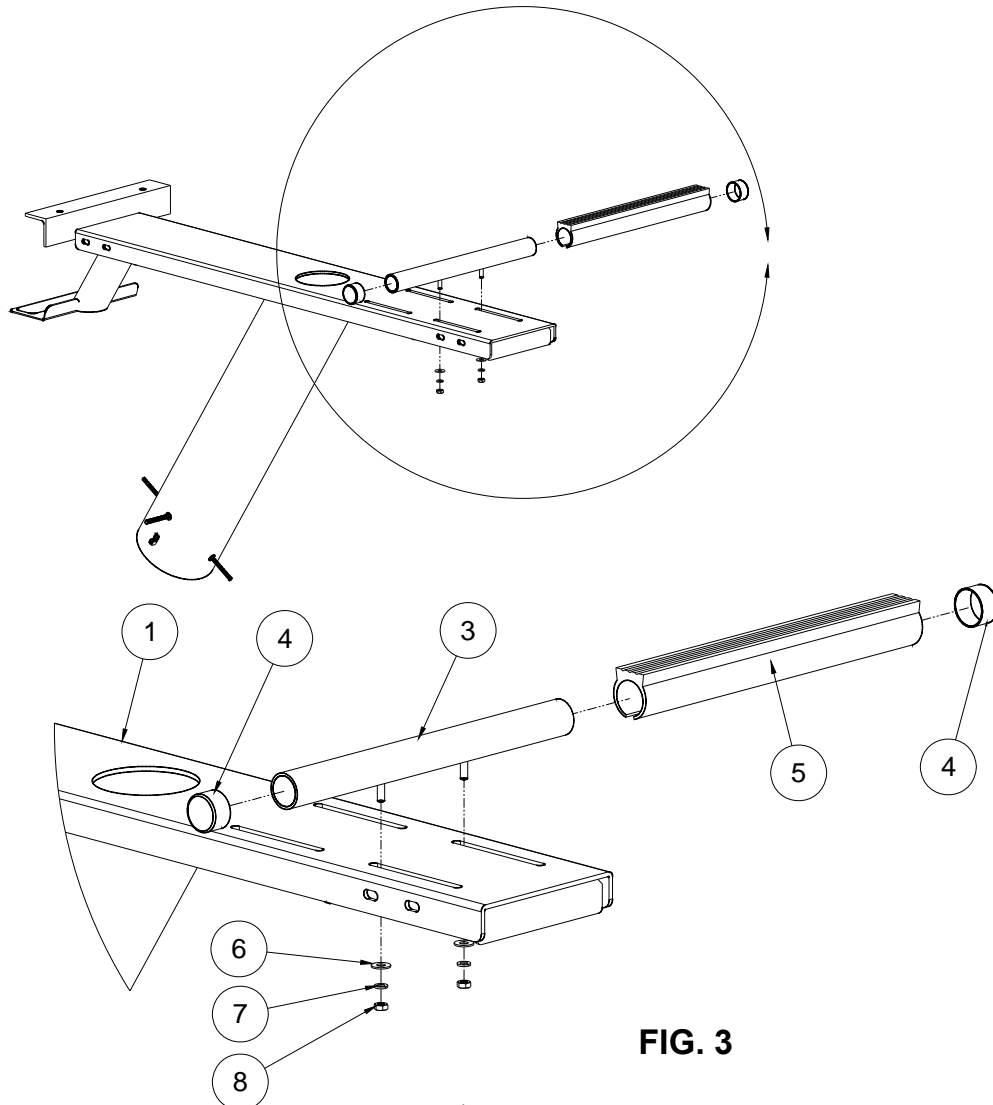

FIG. 3

6. After **Diving Board (item 21)** has been selected, place **Rubber Mounting Pad (item 9)** onto angle plate located on the top, heel end, of the E-CAT stand. Align holes of rubber mounting pad with holes on E-CAT stand. Place diving board on top of rubber mounting pad and align holes of each. Place another rubber mounting pad on top of the diving board. Place **Top Mount Plate (item 16)** over rubber mounting pad and align holes to diving board. Place two (2) $\frac{1}{2}$ " **CARRIAGE BOLTS (item 17)** through holes in top mounting plate, rubber mounting pad, diving board, lower mounting pad and E-CAT stand. Place two (2) $\frac{1}{2}$ " **Lock Washers (item 18)** and two (2) $\frac{1}{2}$ " **Hex Nuts (item 19)** onto carriage bolts. Tighten hex nuts between 20 and 25 ft-lbs. for fiberglass boards, and between 35 and 40 ft-lbs. for aluminum boards. **DO NOT OVER TIGHTEN!** Place $\frac{1}{2}$ " **Nut Caps (item 20)** over hex nuts two (2) places. See **FIG. 4**.

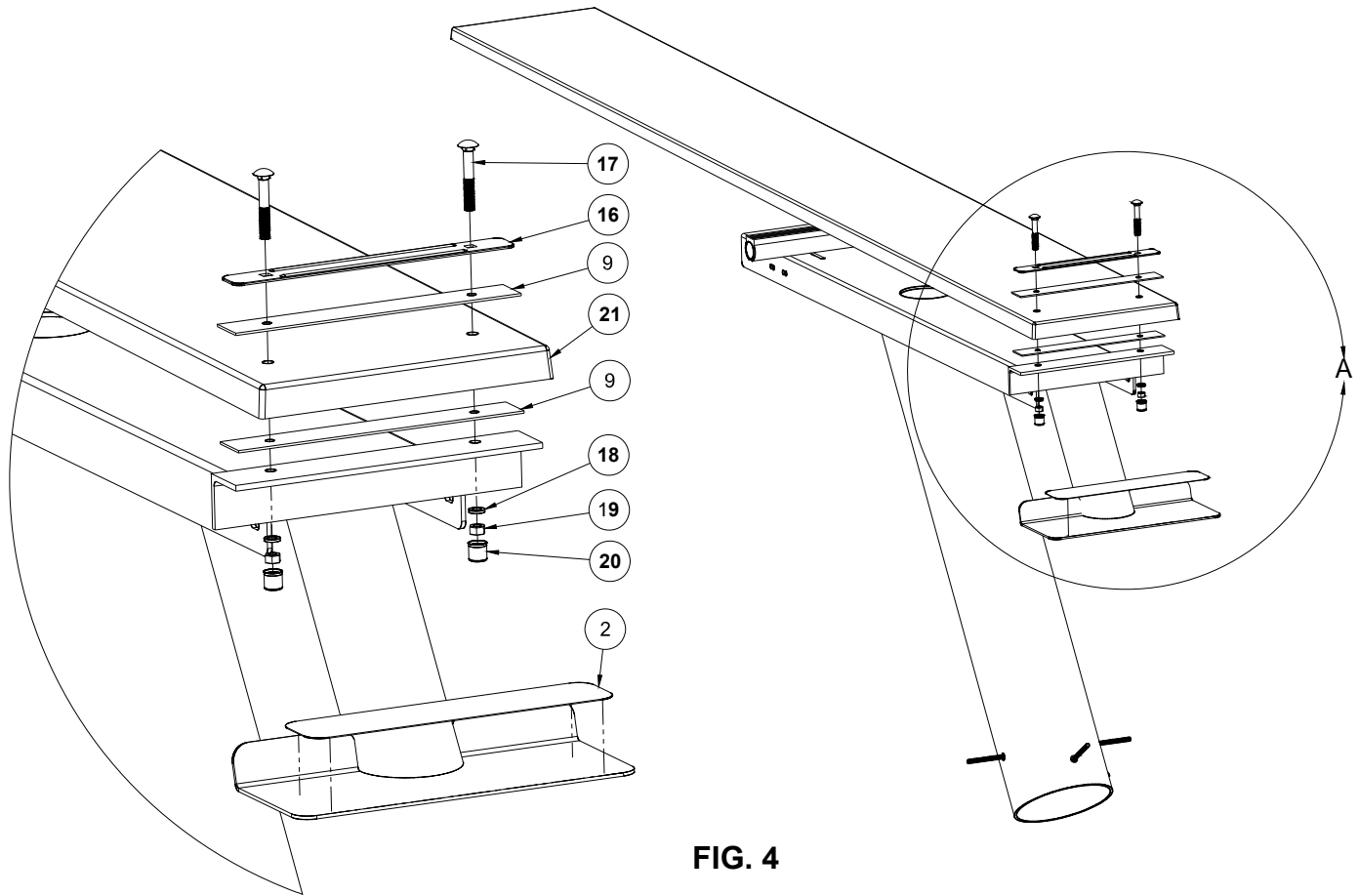

FIG. 4

7. Locate **Handrail Bracket Assembly (item 10)**. Handrail brackets are installed in four (4) places on the E-CAT Stand in the same way. Align slots in E-CAT Stand with slots in handrail bracket and place **3/8" Hex Bolt (item 11)** two (2) places. Place **3/8" Flat Washer (item 6)**, **3/8" Lock Washer (item 7)** and **3/8" Hex Nut (item 8)** onto hex bolts and tighten as shown below, **FIGURE 5**. **Note: Handrails and Handrail Brackets are ordered separately.**

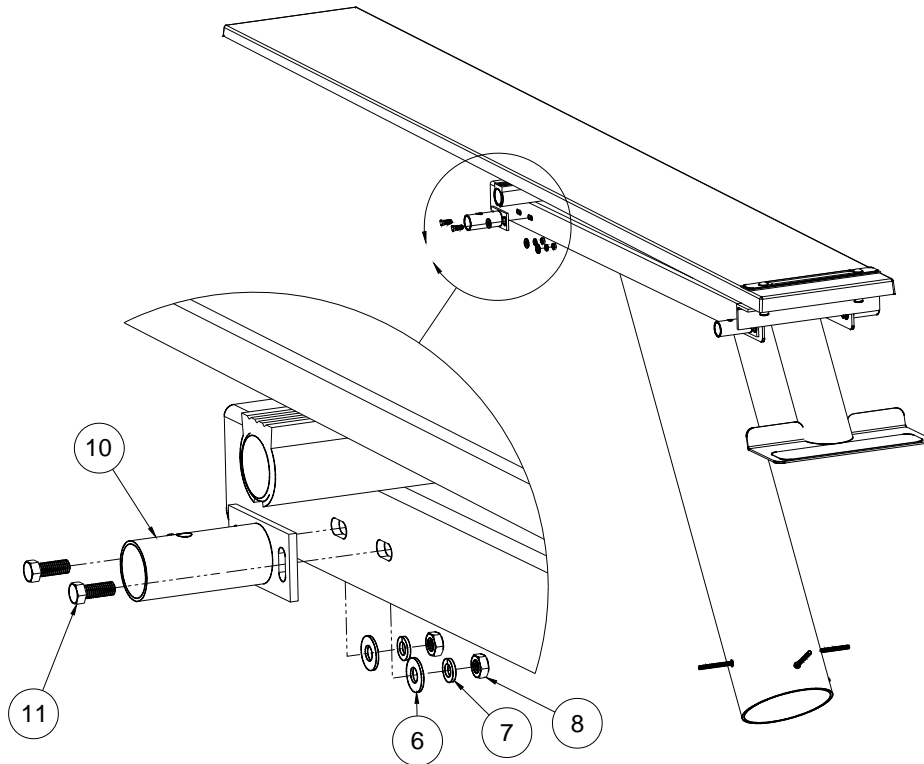

FIG. 5

8. Locate **Handrail (item 21)**, slide over installed handrail bracket assembly and align holes. Place **3/8" Cradle Head Bolt (item 7)** through handrail and handrail bracket. Place **3/8" Lock Washer (item 8)** and **3/8" Hex Nut (item 9)** onto cradle head bolt and tighten. **DO NOT OVER TIGHTEN!** See **FIG. 6**.

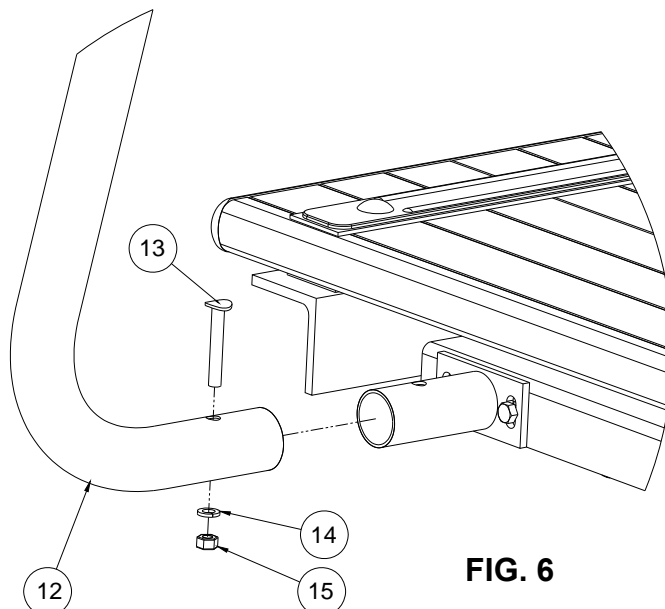

FIG. 6

**Selected Sections From
ANSI/NSPI-1 2003
American National Standard for Public Swimming Pools**

**Standard for
Public Swimming Pools**

1 Scope

1.1 Public swimming pools. This standard covers public swimming pools to be used for bathing and operated by an owner, licensee, or concessionaire, regardless of whether a fee is charged for use.

1.1.1 Public swimming pools covered by this standard. Public swimming pools covered by this standard include Class A pools (pools used for competitive aquatic sports), Class B and Class C pools, (pools intended for public or semi-public recreational swimming), and Class F pools (for wading). (See article 3 for definitions.)

1.2 Variation in design. This standard provides specifications for the design, equipment, operation, warning signs, installation, sanitation, new construction, and renovation of public swimming pools. This standard permits variations in equipment, materials, and design to accommodate special needs and considerations and advances in technology and to provide the required quality, strength, durability, and safety for the intended use.

1.3 Renovation. (See appendix H, Glossary.) Renovation does not include ordinary maintenance. Only those items that are renovated shall adhere to this standard.

2 Normative references

The following standards contain provisions that, through reference in this text, constitute provisions of, this American National Standard. At the time of publication, the editions indicated were valid. All standards are subject to revision, and parties to agreements based on this American National Standard are encouraged to investigate the possibility of applying the most recent editions of the standards indicated below.

ANSI/ASME A112.19.8M-1987 (1996), *Suction fittings for swimming and wading pools, spas, hot tubs, and whirlpool bathtub appliances*¹

ANSI/ICC A 117.1 (2003), *Standard on accessible and useable buildings and facilities*²

ANSI/NEMA-MG1-1998, *Motors and generators*³

ANSI/NSF 14 (2003), *Plastics piping system components and related materials*⁴

ANSI/NSF 50 (2001), *Circulation system components and related materials for swimming pools, spas/hot tubs*⁵

ANSI Z21.56-2001/CSA 4.7-2001, *Gas fired pool heaters*⁶

ACI 302.1R-96 (1996), *Guide for concrete floor and slab construction*⁷

Americans with Disabilities Act (ADA) *Accessibility guidelines for buildings and facilities; recreation facilities*⁸

ASME A112.1.2 (2002), *Air gaps in plumbing systems*⁹

ASTM 1346-91 (2003), *Standard performance specification for safety covers and labeling require-*

¹American National Standards Institute (ANSI), 25 West 43rd Street, New York, NY 10036, NY (212) 642-4900, www.ansi.org

²ANSI, previously listed

³National Electrical Manufacturers Association (NEMA), 1300 N. 11h Street, Suite 1847, Rosslyn, VA 22209 (703) 841-3200, www.nema.org

⁴NSF International, 789 N. Dixboro Rd., Ann Arbor, MI 48113 (734) 769-8010, www.nsforg

⁵NSF, previously listed

⁶ANSI, previously listed

⁷American Concrete Institute, 38800 Country Club Drive, Farmington Hills, MI 48331, (248) 848-3800, www.aci-int.org

⁸U.S. Architectural and Transportation Barriers Compliance Board, 1331 F Street, NW, Suite 1000, Washington, DC 20004, (202) 272-0080, www.access-board.gov

⁹American Society of Mechanical Engineers (ASME), 3 Park Avenue, 20th Floor, New York, NY 10016, (212) 591-8562, www.asme.org

*ments for all covers for swimming pools, spas and hot tubs*¹⁰

ASTM F2208-02, *Standard specification for pool alarms*¹¹

ANSI/NFPA 54-2002, *National fuel gas code*¹²

ANSI/NFPA 70-2002, *National electric code*¹³

UL 1995 (1999), *Standard for heating and cooling equipment*¹⁴

UL 1261 (2001), *Standard for electric water heaters for pools and tubs*¹⁵

3 Definitions

Public swimming pools are classified as follows for purposes of reference and application of this standard:

Class A pools - Class A pools are pools intended for use for accredited competitive aquatic events such as Federation Internationale de Natation Amateur (FINA), U.S.A. Swimming, U.S. Diving, National Collegiate Athletic Association (NCAA), National Federation of State High Schools Associations (NFSHSA), etc. The pool may also be used for recreation. Class A pools are covered unless otherwise noted in the body of the standard.

Class B pools - Class B pools are pools intended for public recreational swimming not otherwise classified. Class B pools are covered within the scope of this standard.

Class C pools - Class C pools are pools intended for use for apartments, condominiums, property owners associations, multi-family owned pools, etc. and are

covered within the scope of this standard. Pools operated solely for and in conjunction with lodgings such as hotels and motels are also covered within the scope of this standard.

Class D pools -Class D pools are not covered within the scope of this standard. Class D pools are operated for special purposes, including but not limited to wave action pools, activity pools, leisure rivers, vortex pools, and sand bottom pools.

Class E pools -Class E pools are pools used for physical therapy and are above 86°F (30°C) and are not covered within the scope of this standard.

Class F pools -Class F pools are wading pools and are covered within the scope of this standard as set forth in 6.9 and 8.4.2 and as noted in other sections of the standard.

4 Code compliance

4.1 Codes. Pools covered by this standard shall be constructed and operated to comply with all local, state, and federal codes governing safety and environmental regulations.

5 General design

5.1 Plans and permits. Prior to construction, rehabilitation, or alteration of a permanently installed public swimming pool, plans and specifications shall be submitted to the authority (state or local) for review, approval, and issuance of a permit to construct or rehabilitate as required by the authority having jurisdiction.

5.2 Materials. Swimming pools and all appurtenances thereto shall be constructed of materials that are nontoxic to humans and the environment; that are generally or commonly regarded to be impervious and enduring; that will withstand the design stresses; and that will provide a watertight structure with a smooth and easily cleaned surface without cracks or joints, excluding structural joints, or to which a smooth, easily cleaned surface/finish is applied or attached.

5.2.1 Selection of materials. Clean sand or similar material, if used in a beach pool environment, shall be used only over an impervious surface. The sand

¹⁰ ASTM International, 100 Barr Harbor Drive, W. Conshohocken, PA 19428, (610) 832-9585, www.astm.org

¹¹ ASTM, previously listed

¹² National Fire Protection Association (NFPA), 1 Batterymarch Park, Quincy, MA 02269 (617) 770-3000, www.nfpa.org

¹³ NFPA, previously listed

¹⁴ Underwriters Laboratories (UL), 333 Pfingsten Road, Northbrook, IL 60062, (847) 272-8800, www.ul.com

¹⁵ UL, previously listed

area shall be designed and controlled so that the circulation system, maintenance, safety, sanitation, and operation of the overall pool are not adversely affected.

5.3 Structural design. The structural design shall be in accordance with accepted engineering practices.

5.4 Freeze protection. In climates subject to freezing temperatures, the pool shell and appurtenances, piping, filter system, pump and motor, and other components shall be designed and constructed to facilitate protection from damage due to freezing.

5.5 Surface condition. The surfaces within the pool intended to provide footing for users shall have a slip-resisting surface and shall not cause injury to the feet during normal use.

5.6 Colors and finishes. The colors, patterns, or finishes of the pool interior shall not obscure objects or surfaces within the pool.

5.7 Accessibility for persons with disabilities. For Americans with Disabilities Act (ADA) requirements for accessibility for persons with disabilities into public swimming pools, see *ADA Accessibility guidelines for buildings and facilities, recreation facilities* (ADAAG).

6 Dimensional design

6.1 Perimeter shape. This standard is not intended to regulate the perimeter shape of swimming pools.

It is the designer's responsibility to take into account the effect a given shape will have on the safety of the occupants and required circulation to ensure sanitation. All other dimensions, unless otherwise specified, should allow ± 2 inches (51 mm) tolerance.

6.1.1 There shall be no protrusions, extensions, means of entanglement, or obstructions in the swimming pool areas that may cause the entrapment or injury of the user.

6.2 Allowable construction tolerances. These construction tolerances are not applicable to Class A pools.

6.2.1 Finished pool dimensions shall be held within the following construction tolerances as shown in table 1.

6.3 Floor slope. Floor slopes shall be in compliance with 6.3.1 through 6.3.5, except the requirements by the ADA Accessibility guidelines (ADAAG).

6.3.1 All pool floors shall be sloped to the drain.

6.3.2 The slope of the floor in the shallow area shall not exceed 1 foot in 10 feet in Class C pools or 1 foot in 12 feet in Class B pools in any direction to the point of the first slope change, if a slope change exists.

6.3.3 The point of the first slope change shall be defined as the point at which the floor slope exceeds 1 foot in 10 feet in Class C pools or 1 foot in 12 feet in Class B pools.

Table 1 – Construction tolerances

Design requirements	Construction tolerance allowed
Length – overall	± 3 in. (76 mm)
Width – overall	± 3 in. (76 mm)
Depth – deep area, including diving area	± 3 in. (76 mm)
Depth – shallow area	± 2 in. (51 mm)
Step treads & risers	$\pm 1/2$ in. (13 mm)
Waterline – pools with adjustable weir skimmers	$\pm 1/4$ in. (6 mm)
Waterline – pools with nonadjustable skimming systems (gutters)	$\pm 1/8$ in. (3 mm)
Wall slopes	± 3 degrees
All dimensions not otherwise specified in this standard	± 2 in. (51 mm)
Competitive pools – Class A pools – All dimensional requirements	As governed by sanctioned authority

6.3.4 The slope of the floor from the point of the first slope change to the deep area shall not exceed 1 foot in 3 feet.

6.3.5 Walls. Where walls join the floor the transitional point or profile shall comply with the following:

- Walls may intersect with the floor at an angle or a transition profile.
- At water depths between 3 feet to 5 feet (91 cm to 152 cm) the maximum radius shall be 2 feet 3 inches (69 cm).
- At water depths of 3 feet (91 cm) or less a transitional radius shall not exceed 6 inches (15 cm) and shall be tangent to the wall and may be tangent to or intersecting the floor.
- At water depths greater than 3 feet (91 cm) a transitional radius shall be tangent to the wall at a point no less than 2 feet and 6 inches (76 cm) below the water surface and may progressively increase from 6 inches (5 cm) to a value capable of being tangent to or intersecting the floor.

6.4 Water depths for swimming areas shall be a minimum depth of 3 feet (91 cm) unless the authority having jurisdiction specifies otherwise.

6.4.1 Class A pools shall be designed and constructed to provide the dimensions specified by Federation Internationale de Natation Amateur (FINA), U.S.A. Swimming, U.S. Diving, or other appropriate sanctioning body.

6.5 Diving. This standard does not cover diving requirements for Class A pools. This standard covers diving requirements for Class B and Class C pools.

6.5.1 When diving equipment is installed, it shall conform to the specifications set forth in 7.2.1 through 7.2.5.6. Equipment shall be located in the diving area of the pool on the appropriate ANSI/NSPI pool type (or other water envelopes specified by the diving equipment manufacturer) in accordance with the manufacturer's installation instructions and the minimum dimensions as shown in figure 1. Competitive diving equipment shall not be installed on Class B and Class C pools.

6.6 The manufacturer of the diving equipment shall specify minimum water envelopes for its products. They may refer to the water envelope type of their choice by dimensionally relating their products to Point "A" on that water envelope. Point "A" as shown in figure 1 is designated as the point of origin on the water surface for the water envelope dimension.

6.6.1 Point A is a point located on the water surface of pool water envelopes.

6.6.2 Point A is a construction location nearest the deep end wall where the minimum water depth D_1 is satisfied.

6.6.3 Point A, as shown in figure 1 and table 2, shall be the referenced point of origin for all dimensions defining a minimum water envelope.

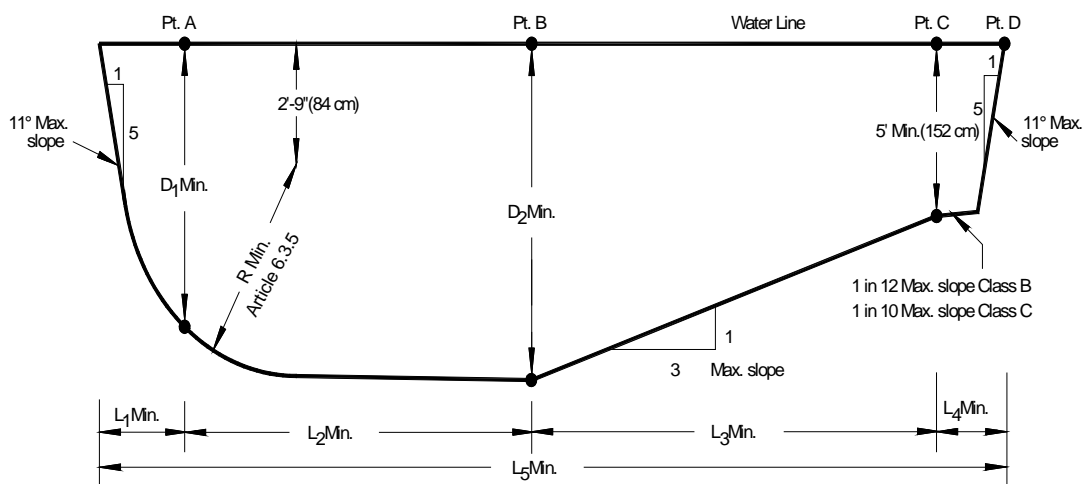

Figure 1 – Construction dimensions for water envelopes for Class B and Class C pools

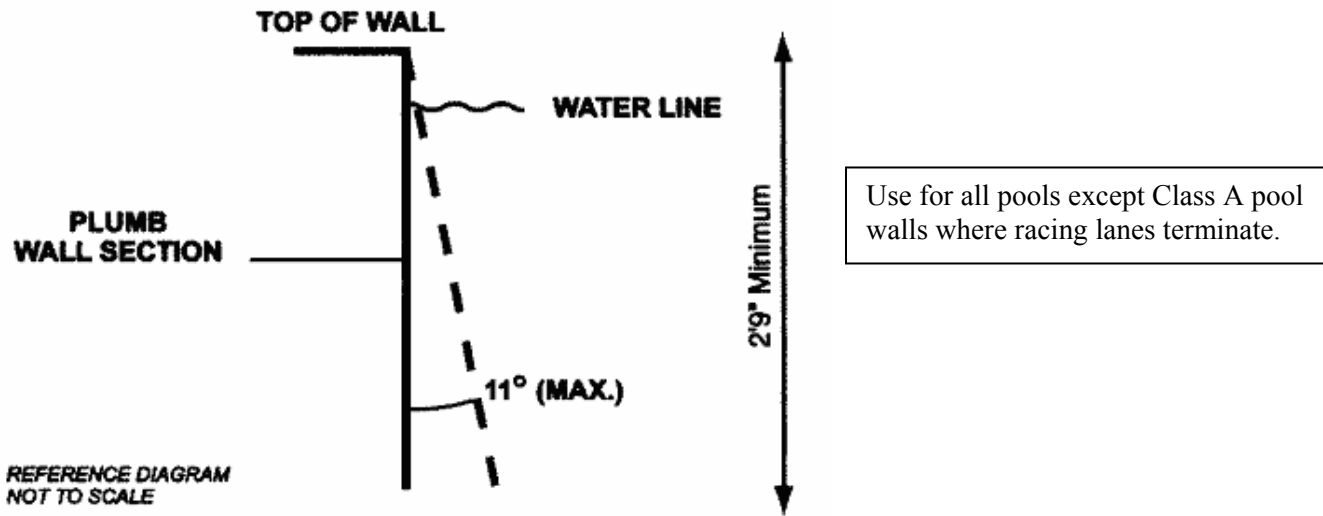

Figure 2 – Maximum allowable wall slope

Table 2 – Minimum water envelopes

Pool type	Minimum dimensions								Minimum width of pool at:		
	D ₁	D ₂	R	L ₁	L ₂	L ₃	L ₄	L ₅	Pt. A	Pt. B	Pt. C
VI	7'-0" (213 cm)	8'-6" (259 cm)	5'-6" (168 cm)	2'-6" (76 cm)	8'-0" (244 cm)	10'-6" (320 cm)	7'-0" (213 cm)	28'-0" (853 cm)	16'-0" (488 cm)	18'-0" (549 cm)	18'-0" (549 cm)
VII	7'-6" (229 cm)	9'-0" (274 cm)	6'-0" (183 cm)	3'-0" (91 cm)	9'-0" (274 cm)	12'-0" (366 cm)	4'-0" (122 cm)	28'-0" (853 cm)	18'-0" (549 cm)	20'-0" (610 cm)	20'-0" (610 cm)
VIII	8'-6" (259 cm)	10'-0" (305 cm)	7'-0" (213 cm)	4'-0" (122 cm)	10'-0" (305 cm)	15'-0" (457 cm)	2'-0" (61 cm)	31'-0" (945 cm)	20'-0" (610 cm)	22'-0" (671 cm)	22'-0" (671 cm)
IX	11'-0" (335 cm)	12'-0" (366 cm)	8'-6" (259 cm)	6'-0" (183 cm)	10'-6" (320 cm)	21'-0" (640 cm)	0 (0 cm)	37'-6" (11.4 m)	22'-0" (671 cm)	24'-0" (732 cm)	24'-0" (732 cm)

Table 3 – Maximum user load

Pool/Deck area	Shallow instructional or wading areas	Deep area (not including the diving area)	Diving area (per each diving board)
Pools with minimum deck area (See 7.1.6 through 7.1.6.1.)	15 sq. ft. per user (1.35 m ² per user)	20 sq. ft. per user (1.8 m ² per user)	300 sq. ft. per user (27 m ² per user)
Pools with deck area at least equal to water surface are	12 sq. ft. per user (1.08 m ² per user)	15 sq. ft. per user (1.35 m ² per user)	300 sq. ft. per user (27 m ² per user)
Pools with deck area at least twice the water surface are	8 sq. ft. per user (0.72 m ² per user)	10 sq. ft. per user (0.9 m ² per user)	300 sq. ft. per user (27 m ² per user)

6.7 Rest ledges. Rest Ledges along the pool walls are permitted. They must be not less than 4 feet (122cm) below the water surface. If a ledge is provided it shall be at least 4 inches (10 cm) wide and not more than 8 inches (20 cm) wide.

6.8 Maximum user load. The maximum user load of Class B or Class C pools shall be in accordance with table 3.

6.9 Wading pools. A wading pool shall be a separate pool with an independent circulation system and physically separated from the main pool as described in 6.9.1 through 6.9.4.

6.9.1 Areas where the water depth at the edge of the pool exceeds 9 inches (23 cm) shall be considered non-entry areas and must be protected by natural or artificial barriers.

6.9.2 Floors of wading pools shall be uniform and sloped to drain with a minimum slope of 1 foot in 12 feet (30 cm in 360 cm).

6.9.3 The maximum water depth shall be 18 inches (46 cm).

6.9.4 The Maximum distance from the top of the deck to the water line shall not exceed 6 inches (15 cm).

7 Decks and deck equipment.

7.1 Decks shall comply with 7.1.1 through 7.1.17 as applicable.

7.1.1 Deck(s) shall be designed and installed in accordance with the engineering methods required by the authority having jurisdiction.

7.1.1.1 In the absence of specific local requirements, a concrete deck shall be designed and constructed in accordance with the recommended practices of the most recent edition of American Concrete Institute (ACI) Standard 302.1R-96, *Guide for concrete floor and slab construction*, or in accordance with the requirements of the local authority, the authority having jurisdiction, or both. The deck shall be designed and constructed to meet the applicable requirements of the Americans with Disabilities Act.

7.1.2 Decks, ramps, coping, and similar step surfaces shall be slip resisting and cleanable.

7.1.3 Special features in or on deck(s) such as markers, brand insignias, or similar materials shall be slip resisting.

7.1.4 Step risers for the deck shall be uniform and have a minimum height of 3-3/4 inches (9.5 cm) and a maximum height of 7-1/2 inches (19 cm). A handrail shall be provided for stairs having three or more risers. The minimum tread distance from front to back shall be 11 inches (28 cm).

7.1.5 The deck or unobstructed access shall be provided at a minimum of 65% of the pool perimeter to meet the requirement of the 10/20 rule. (See appendix H, Glossary.)

7.1.5.1 A minimum 4 feet (122 cm) deck width shall be provided on the sides and rear of any diving equipment. A deck clearance of 3 feet (91 cm) shall be provided around all other deck equipment.

7.1.6 The minimum slope of the deck(s) shall be 1/8 inch per 1 foot (3.2 mm per 304.8 mm) for textured, hand-finished concrete decks; 1/4 inch per 1 foot (6.4 mm per 304.8 mm) for exposed aggregate

concrete decks; 1/2 inch per 1 foot (12.7 mm per 304.8 mm) for indoor/outdoor carpeting decks; and 3/8 inch per 1 foot (9.5 mm per 304.8 mm) for brick and heavy textures finishes, unless an alternate drain- age method is provided that prevents the accumulation of pooling of water. (See table 4.)

7.1.6.1 Decks shall be sloped so that standing water shall be no deeper than 1/8 inch (3.2 mm), 20 minutes after the cessation of the addition of water to the deck.

NOTE -Two stacked U.S. quarters can be used to measure the depth. Water should not cover the quarters.

7.1.7 The maximum slope of all decks, other than wood decks, shall be 1/2 inch per foot (12.7 mm per 304.8 mm) except for ramps.

7.1.7.1 The maximum slope for wood decks shall be 1/8 inch per 1 foot (3.2 mm per 304.8 mm).

7.1.7.2 Gaps shall be required between deck boards in wood decks and shall be consistent with approved engineering methods with respect to the type of wood used and shall not cause a tripping hazard.

7.1.8 The maximum open gap between pool decks and adjoining decks or walkways, including joint material, shall be 3/4 inch (19.1 mm). The difference in vertical elevation between the pool deck and the adjoining sidewalk shall be 1/4 inch (6.4 mm) unless it conforms to 7.1.4.

7.1.9 Construction joints where the pool coping meets the concrete deck(s) shall be watertight.

7.1.10 Construction joints where the pool coping meets the concrete deck(s) shall be installed to protect the coping and its mortar bed from damage as a result of the anticipated movement of adjoining deck(s).

7.1.11 Control joints in deck(s) shall be provided to minimize visible cracks outside the control joints due to imposed stresses and/or movement of the slab.

7.1.12 Areas where decks join existing concrete work shall be protected by an expansion joint to protect the pool from the pressures of relative movements.

7.1.13 The edges of all decks shall be radiused, tapered, or otherwise designed to eliminate sharp comers.

7.1.14 Pressure tests. A pressure test shall be maintained throughout the deck pour and in accordance with 8.4.

7.1.15 Valves installed in or under any deck(s) shall have access provided for operation, service, and maintenance. Access covers shall be provided.

7.1.16 Hose bib(s), with a cross connection control to prevent backflow, shall be provided for rinsing down the entire deck and shall be in accordance with the authority having jurisdiction.

7.1.17 Water-powered devices (such as water-powered lifts) shall have a dedicated hose bib (water source).

7.2 Deck equipment. Deck equipment including diving facilities and starting blocks shall comply with 7.2.1 through 7.4 as applicable.

Table 4 – Typical minimum drainage slope

Surface	Typical minimum drainage slope (inch per foot)
Textured, hand-finished concrete	1/8 in. (3.2)
Exposed aggregate	1/4 in. (6.4 mm)
Carpet	1/2 in. (12.7 mm)
Brick and heavy textures finished	3/8 in. (9.5 mm)

7.2.1 A minimum 4 feet (122 cm) deck width shall be provided on the sides and rear of any diving equipment.

7.2.2 Starting blocks. Starting blocks are intended for competitive swimming and shall conform to Federation Internationale de Natation Amateur (FINA), U.S.A. Swimming, National Collegiate Athletic Association (NCAA), or National Federation of State High Schools Associations (NFSHSA).

7.2.3 There shall be a completely unobstructed distance of 14 feet (427 cm) above the tip of the diving board or as specified by the diving equipment manufacturer or the authority having jurisdiction.

7.2.4 Public pools with diving equipment of 1 meter (39 inches) or greater in height, or pools designed for springboard or platform diving, shall comply with the dimensional design requirements of Federation Internationale de Natation Amateur (FINA), U.S. Diving, National Federation of State High Schools Association (NFSHSA) or the appropriate sanctioning body.

7.2.5 Diving equipment. Diving equipment shall be installed in accordance with the manufacturer's specifications.

7.2.5.1 The diving equipment manufacturer shall affix a label to the diving equipment.

7.2.5.2 A label shall be permanently affixed to the diving equipment or jump board and shall include but not be limited to the following:

- The minimum water envelope required for each diving board and diving stand combination,
- Manufacturer's name and address,
- Manufacturer's identification and date of manufacture, and
- The maximum weight of the user, visibly located on the diving board.

7.2.5.3 The diving equipment manufacturer shall provide diving equipment use instructions.

7.2.5.4 Diving equipment shall have slip-resisting tread surfaces.

7.2.5.5 Supports for diving equipment. Supports, platforms, stairs, and ladders for diving equipment shall be designed to carry the anticipated loads. Stairs and ladders shall be of corrosion-resisting material and shall be easily cleanable and with slip-resisting tread. All diving stands higher than 21 inches (53 cm) measured from the deck to the top butt end of the board shall be provided with stairs and/or a ladder. Step treads shall be self-draining.

7.2.5.6 Diving equipment 1 meter high (39 inches) or greater shall be provided with a top guard rail, which shall be at least 30 inches (76 cm) above the diving board and extend to the edge of the pool wall and to the deck surface.

7.3 Swimming pool slides. Swimming pool slides, when installed, shall comply with the requirements of the U.S. Consumer Product Safety Commission (CPSC) as published in the *Code of Federal Regulations*, 16 CFR, Part 1207. The manufacturer shall provide installation and use instructions with each slide. Each slide shall be installed in accordance with the manufacturer's instructions.

7.4 Play/water activity equipment. When installed, play/water activity equipment shall be installed in accordance with manufacturer's instructions.

For a copy of the complete ANSI/NSPI-1 2003 American National Standard for Commercial Inground Swimming Pools contact:

National Spa and Pool Institute
2111 Eisenhower Avenue
Alexandria, VA 22314
Phone: (703) 838-0083
Fax: (703) 549-0493
www.nspi.org